

## Monospace and Multiverse: Exploring Space with Actor-Network-Theory

Hansmann, Sabine

Veröffentlichungsversion / Published Version

Monographie / phd thesis

Zur Verfügung gestellt in Kooperation mit / provided in cooperation with:

transcript Verlag

Gefördert durch die Deutsche Forschungsgemeinschaft (DFG) - Projektnummer EXC 2025 - 390648296 / Funded by the German Research Foundation (DFG) - Project number EXC 2025 - 390648296

### Empfohlene Zitierung / Suggested Citation:

Hansmann, S. (2021). *Monospace and Multiverse: Exploring Space with Actor-Network-Theory*. (Materialities, 28). Bielefeld: transcript Verlag. <https://doi.org/10.14361/9783839455029>

### Nutzungsbedingungen:

Dieser Text wird unter einer CC BY Lizenz (Namensnennung) zur Verfügung gestellt. Nähere Auskünfte zu den CC-Lizenzen finden Sie hier:

<https://creativecommons.org/licenses/by/4.0/deed.de>

### Terms of use:

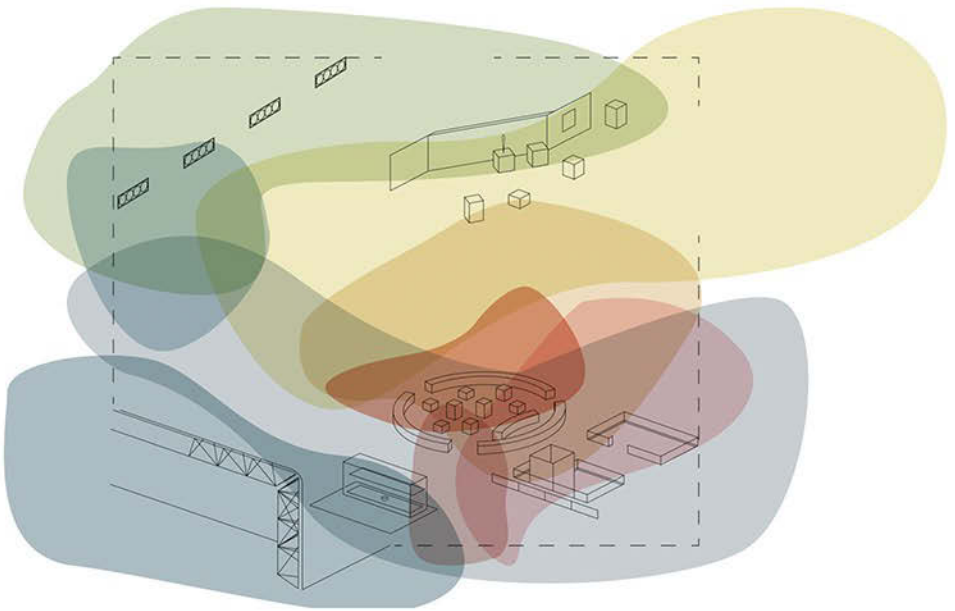
This document is made available under a CC BY Licence (Attribution). For more information see:

<https://creativecommons.org/licenses/by/4.0>

Sabine Hansmann

# Monospace and Multiverse

Exploring Space  
with Actor-Network-Theory



Sabine Hansmann  
Monospace and Multiverse

## Editorial

The series is edited by Gabriele Klein, Martina Löw und Michael Meuser.

**Sabine Hansmann** (Dr.-Ing) is a researcher at the *Institute for the History and Theory of Architecture and the City* at the Technische Universität Braunschweig. She teaches at the COOP Design Research Program by Bauhaus Dessau Foundation and Hochschule Anhalt in cooperation with Humboldt-Universität zu Berlin. From 2013-2018 she was a member of the *Laboratory for Integrative Architecture* at the Technische Universität Berlin and the Cluster of Excellence *Image Knowledge Gestaltung. An Interdisciplinary Laboratory* at the Humboldt-Universität zu Berlin. Both provided the framework for her doctoral thesis (2019). In 2017, she was a visiting researcher at the Manchester Architecture Research Group (MARG). Her research focuses on architecture, urbanism, spatial theory, actor-network-theory and material semiotics.

Sabine Hansmann

## **Monospace and Multiverse**

Exploring Space with Actor-Network-Theory

**[transcript]**

This publication was made possible by the Open Access Publication Fund of the Technische Universität Berlin. Furthermore, the author acknowledges the support of the Cluster of Excellence »Matters of Activity. Image Space Material« funded by the Deutsche Forschungsgemeinschaft (DFG, German Research Foundation) under Germany's Excellence Strategy – EXC 2025 – 390648296.



This publication is a revised version of the author's doctoral thesis, accepted by Faculty VI - Planning Building Environment at the Technische Universität Berlin in 2019.

#### **Bibliographic information published by the Deutsche Nationalbibliothek**

The Deutsche Nationalbibliothek lists this publication in the Deutsche Nationalbibliografie; detailed bibliographic data are available in the Internet at <http://dnb.d-nb.de>



This work is licensed under the Creative Commons Attribution 4.0 (BY) license, which means that the text may be remixed, transformed and built upon and be copied and redistributed in any medium or format even commercially, provided credit is given to the author. For details go to <http://creativecommons.org/licenses/by/4.0/>  
Creative Commons license terms for re-use do not apply to any content (such as graphs, figures, photos, excerpts, etc.) not original to the Open Access publication and further permission may be required from the rights holder. The obligation to research and clear permission lies solely with the party re-using the material.

**First published in 2021 by transcript Verlag, Bielefeld**

© **Sabine Hansmann**

Cover concept: Kordula Röckenhaus, Bielefeld  
Cover illustration: Sabine Hansmann  
Proofread: Nathaniel Boyd  
Typeset: Carola Plappert, München  
Printed by Majuskel Medienproduktion GmbH, Wetzlar  
Print-ISBN 978-3-8376-5502-5  
PDF-ISBN 978-3-8394-5502-9  
<https://doi.org/10.14361/9783839455029>

Printed on permanent acid-free text paper.

# Table of Content

---

<b>Acknowledgements</b>	<b>9</b>
<b>1 Introduction</b>	<b>13</b>
1.1 Rethinking Space with Monospace	14
1.2 A Realist Account on Architectural Space	21
1.3 A Current Debate: Architecture and the Social	27
1.4 Structure of the Book	32
1.5 Writing Style	34
<b>2 Opening the Box</b>	<b>37</b>
2.1 Open-Plan and Monospace	38
2.2 Which Space? Stability versus Flux	45
2.2.1 Space as Practice	49
2.2.2 Spacing: A Networked Space	53
2.3 Agency: Who Else Is Acting?	55
2.4 Components of the Inquiry	59
<b>3 The Case: The Sainsbury Centre for Visual Arts</b>	<b>65</b>
3.1 Exploring the Building According to the Plans	67
3.1.1 A Single Volume	71
3.1.2 Zoning and Circulation	76
3.1.3 Construction and Conditioning	88
3.2 Perspectives on the Building as ...	91
3.2.1 ... a High-tech and Late Modern Museum Building	91
3.2.2 ... the First Public Commission of a Star Architect	94
3.2.3 ... a Piece of Art	98
3.3 Approaching the Building in Practice	101
<b>4 In Practice I: Working-With</b>	<b>103</b>
4.1 Taking a Walk: Introduction to the Guides	105
4.2 First Stop: Gallery 1	107

4.2.1	Two Building Parts?	109
4.2.2	Working with the Building	110
4.2.3	Flexibility: The Work of Many	112
4.3	Second Stop: East End Gallery	114
4.3.1	Defining in Relation	115
4.3.2	Unpredictable »Mediator«	117
4.4	Third Stop: Living Area	120
4.4.1	Stopover: A Connection to the Patio	121
4.4.2	In Its »Script« Anti-Museum	122
4.4.3	Stability: The Work of Many	125
4.4.4	Heterogeneity in Practice	131
4.5	Conclusion: Connectivity in Spacing	135
<b>5</b>	<b>In Practice II: Visiting</b>	<b>139</b>
5.1	Sketching Experiences	141
5.2	Arriving	142
5.2.1	Facing Practicalities	147
5.2.2	Networks of Arrival	149
5.3	Exploring	151
5.3.1	Walking with the Objects	154
5.3.2	Looking Down	156
5.4	Returning	160
5.5	Conclusion: Multiplicity and Experience	163
<b>6</b>	<b>In Practice III: Lighting</b>	<b>167</b>
6.1	Tracing the Object	169
6.2	Opening Up and Spreading	172
6.2.1	Who Does the Light?	173
6.2.2	Letting the Light Show Through	174
6.2.3	The Generosity of Light	177
6.3	Layering	187
6.3.1	Moving with Intensities	191
6.3.2	Light and Shadow	193



6.4	Monitoring and Rotating	195
6.4.1	Condition of Movement	197
6.4.2	The Controversy of Light	198
6.5	Conclusion: Spacing Devices	201
<b>7</b>	<b>A New Dynamism in Architecture</b>	<b>203</b>
7.1	Spacing the Monospace	205
7.2	The Building as an Actor	211
7.3	The Disappearance of the User	213
7.4	Architects Amongst Many Experts	214
7.5	Tracing an Architectural World in Flux: Some Methodological Reflections	216
7.6	When Space Is Never 'Completed'	218
	<b>List of Figures</b>	<b>223</b>
	<b>Building Details</b>	<b>227</b>
	<b>Bibliography</b>	<b>229</b>



## Acknowledgements

---

*Monospace* is a term I learned about from Finn Geipel who encouraged me to find and take my own path exploring its possibilities. My gratitude goes to him for giving me the opportunity to be part of the *Laboratory for Integrative Architecture* (LIA) at Technische Universität Berlin and subsequently a member of the *Cluster of Excellence Image Knowledge Gestaltung* (BWG) at the Humboldt-Universität Berlin in which I was also member of the structured doctoral programme. Both institutions put me in a unique situation that made this work possible. Finn's trust, support and discussion of this work but also the given freedom to experiment have been invaluable throughout the years. I would like to thank both teams from LIA and BWG for the great and intense times I was allowed to be part of. BWG must also be mentioned here, since it made the research financially possible. They supported my work in the making and financed, among other things, my research stays in Manchester and Norwich—for all of this I am most grateful.

*Multiverse* on the contrary is a term that I encountered in an article by Albena Yaneva. Visiting her at the *Manchester Architectural Research Group* (MARG) during my studies, Albena provided me with the necessary tools and important comments that helped to improve my work tremendously. I am grateful for her time and the effort that she spent. Inviting me to MARG set the course for writing and provided me with an environment of fruitful conversations, joined readings and discussions. Here, I would like to particularly thank Brett Mommersteeg, Fadi Shayya, Stelios Zavos and furthermore Demetra Kourri and Efstathia Dorovitsa with whom I shared wonderful moments and who have given important impulses for the development of this work.

While *Monospace* and *Multiverse* in a certain sense stand for the beginning and end of this study, I would like to stress that this work is not about a path from the former to the latter. On the contrary it is a journey into architectural space that could unfold only in this field of tension. A decisive factor for this work, however, was a further exceptional place, the Sainsbury Centre for Visual Arts in Norwich. I would like to thank the team of the Sainsbury Centre Institute, the university's teachers, students, visitors, and others who took the time and participated in my research in the period between 2016–17. In particular, I would like to thank Meryl

Taylor and Calvin Winner for their constant support and assistance throughout all my research stays and the many enriching conversations.

Writing a dissertation is a solitary affair, however I was fortunate enough to have many additional colleagues and friends aside from those already mentioned who supported me throughout this journey. Thanks go to Eva Castringius, Alina Enzensberger, Carola Fricke, Peter Koval, Ines Lüder, Zorica Medjo, Sandra Meireis, Julia von Mende, Nicole Opel, Friederike Schäfer, Kathrin Schlenker, Verena Schmidt, Verena Straub and Niloufar Tajeri. A particular thanks is reserved for Séverine Marguin who has accompanied me especially from the field of sociology in an advisory manner throughout the years. I wish to extend my gratitude also to the former student assistants at BWG and amongst them especially to Maria Lisenko who assisted me in the preparation, implementation and follow up of one of the first research stays. Further thanks to the lector Nathaniel Boyd who cheered me on in the last few weeks before submission and who gave the final script a careful reading, and also to the graphic designer Carola Plappert who provided for the inner layout of this book.

This publication was financially supported by the Open Access Publication Fund of the Technische Universität Berlin and by the *Cluster of Excellence Matters of Activity* (MOA) at the Humboldt-Universität Berlin. For both I am very grateful. My thanks furthermore go to the Technische Universität Braunschweig and here to the *Institute for the History and Theory of Architecture and the City* (GTAS) that provided me with the necessary resources for the final editing. For their professional guidance I would like to thank the team of transcript as well as Gabriele Klein, Martina Löw and Michael Meuser, editors of the series *Materialities*, for their sponsorship.

Finally, a huge thank you to my family who, collectively, gave me encouragement, support, and confidence. Most importantly to Fabian and Finja whom I am most grateful to have at my side and who granted me serenity. But also, to my parents who supported me greatly through all stages of my academic path. This book is dedicated to them.

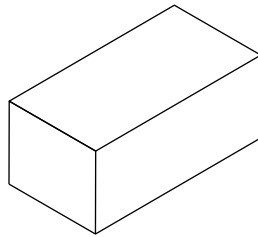




# 1

## Introduction

---



**Fig. 1.1:**  
Box containing space.

Can there be a building with only one space? If you are an architect, your answer will be most likely, yes of course. Depending on your age, you might think of the KAIT Workshop (2008) by architect Junya Ishigami in Kanagawa, Japan. Or a bit larger, the Neue Nationalgalerie (1968) by Ludwig Mies van der Rohe in Berlin, Germany. But maybe you had a glance at this sketch above first (**Fig. 1.1**), and you are simply thinking of a shipping container, frequently used as site offices. No matter what reference you have in your mind, let us call these buildings ‘monospace’. We will then have to see why this might be interesting.<sup>1</sup>

Can there be a movement *with* space? The answer is not quite so simple. That said, we indeed can consider movement as an action *with* space, a movement that is shaped and re-arranged by many ingredients and which generate space

---

<sup>1</sup> I take up the term ‘monospace’ from the architect and urbanist Finn Geipel (Geipel, Koch, and Thorwarth 2011) who groups under this typology buildings which distinguish themselves by one outer shell with a maximally open floor plan.

in the course of action. This is not about a movement that occurs *within* a pre-existing space but is instead a movement that is actively producing space. Let us call this process of space-making ‘spacing’ and see why this concept might be challenging for the notion of monospace, and revealing for our understanding of buildings, architects and ‘users’, and thus for architectural theory in general.<sup>2</sup>

## 1.1

### Rethinking Space with Monospace

Rethinking space with monospace starts with a paradox. Concerned with a building, which is often called a ‘box’, ‘shed’ or ‘aircraft hangar’, and that comprises so much space that it can be described as the ‘container space’ par excellence.<sup>3</sup> This book sets out to challenge a traditional understanding of space in the field of architecture. Opposing a space that can be entered and a view of architecture as an objective frame that surrounds and contains, I approach the typology of monospace and argue that space is not what happens *in* a building but space happens *with* a building. What at first sounds like a little intellectual pun quickly turns out to be a fundamental shaking of belief systems in the discipline of architecture. After all, the question of space is closely linked to the question of the relationship between architecture and social life. Both of which are currently being re-negotiated in an interdisciplinary context (Jacobs and Merriman 2011; Yaneva 2012, 2009b; Delitz 2009a; Löw 2001; cf. also Heynen 2013). This undertaking to explore a monospace through ‘spacing’ is thus not only an empirically based study on the topic of space in the field of architecture but furthermore aims to contribute to recent scholarship in re-thinking and re-conceptualising architecture’s relations (Till 2013; Yaneva 2017; Latour and Yaneva 2008).

However, let us take a step back and define more precisely the subject at hand. Monospace is a specific form of open plan building.<sup>4</sup> To understand a monospace seems at first glance rather simple as it consists—in its most radical

---

2 I take the term ‘spacing’ up from French sociologist and philosopher Bruno Latour (1997) and not as might be expected in German-speaking countries from sociologist Martina Löw (2001). Both approaches are examined in more detail in Chapter 2.

3 Albert Einstein coined the term ‘container’ space in distinction to a relational understanding of space (Einstein 1954, XV).

4 The first tentative steps toward a definition of monospace and its interrogative potential for the topic of space in the field of architecture were elaborated previously in a co-authored article by myself and Finn Geipel *Über Hüllen und Werden* (Geipel and Hansmann, forthcoming).



cases—of only one room. The KAIT Workshop (2008) by Japanese architect Junya Ishigami, a studio and workshop on the campus of the Kanagawa Institute of Technology, Japan, is such a radical monospace building (Fig. 1.2, 1.4).<sup>5</sup> Comprised of roughly 2000 square meters in a single room, this flat single-storey structure has all-glass façades. The room is not empty but structured into various zones by 305 thin columns of different proportions scattered about in various densities. In between there are plants, chairs, tables, workbenches, machines and all sorts of things. Such a rich material world loosely defines different possibilities of action. Clay is processed at the turntables near the water basins, wood close to the circular saw on the workbenches. That said, the daily hustle and bustle, the trajectories of the objects, the circling and meandering movements of the students, the three to five workshop managers who are present teaching, supervising and coordinating this field of possibilities, quickly reveals that this monospace is highly complex. To grasp this building in its architectural quality we have to move ‘inside’ to take a closer look. The glass shell surrounding the container space gives little indication of the actual possibilities that emerge in the course of action. In contrast to buildings divided by walls into a sequence of rooms, monospaces are determined far less by the building shell than by a reciprocal relationship between space and practice and objects, materials and human bodies. The architect Ishigami compares this situation with the emergence of a landscape in which the notion of architecture as framework disappears:

When a state of equilibrium is reached by the architecture and other elements in the process of giving form to a space, the result is more like a landscape than like architecture. The character of architecture as the framework that forms space disappears. This phenomenon can be linked to people, cars, vegetation and buildings becoming equal components in a landscape without any particular hierarchy. (Ishigami 2010, 24)

---

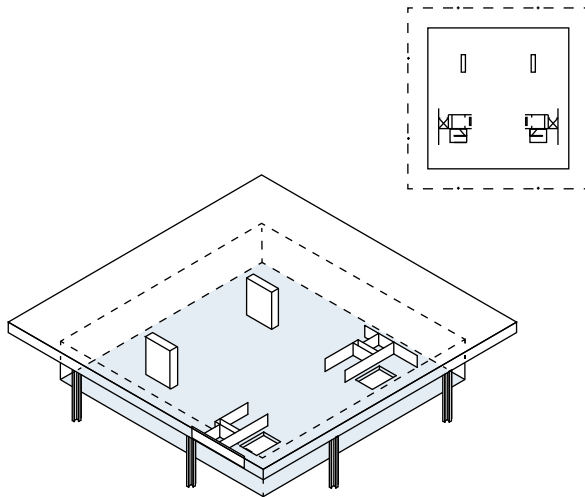
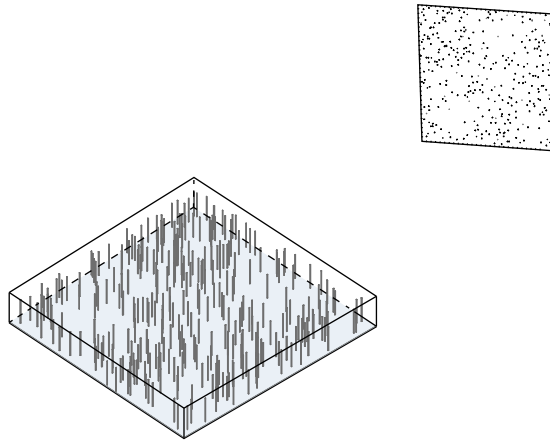
5 For additional information on the KAIT Workshop, see *Junya Ishigami: Small Images* (2008, particularly 28–43).

Contemporary studies of another monospace, the Neue Nationalgalerie (1968) by Mies van der Rohe in Berlin (Fig. 1.3, 1.5),<sup>6</sup> reveal the challenges of conceptualising and analytically grasping this architecture, which is apparently open to constant change. As I argue, to account for the reality of such buildings it is insufficient to do so on the basis of their technicality. In other words, monospace buildings cannot be understood simply by focusing on the material object. To merely read their plans, sections or static pictures (Woelk 2010) is not enough. Nor is it sufficient to study them through the movements of the ‘phenomenological’ body that pass through them, focusing on sensorial perceptions and atmospheres or decoding symbolic meanings (Leyk 2010). With monospace buildings, it is particularly essential to turn to the reality of the building in the process of use in order to overcome the separation of ‘objective’ and ‘subjective’ space. The former defined by numbers and measurements, the latter emerging around the human beings that perceive it. This very dichotomy that reduces the building to passive material, however, while making human life into the active component is very much anchored in the prevalent way of thinking about space in architecture.

In the course of the 20th century, space was declared the ‘essence’ of architecture (Scott 1914; Giedion 1954 [1941]; Zevi 1957 [1948]). In this respect architects became *shapers* of space: ‘If, for a particular purpose, we separate, limit and bring into a human scale a part of unlimited space, it is (if all goes well) a piece of space brought to life as reality.’ (Rietveld 1958, 162) Consequently, architecture became a discipline concerned with the task of shaping space. Ideas of space are by no means homogeneous (Denk, Schröder, and Schützeichel 2016; Forty 2004). Nevertheless, traditional spatial concepts still predominate most contemporary discussions, such as the idea that space is what is contained within an object (Hilger 2011; Till 2013; Awan, Schneider, and Till 2011). This goes hand in hand with the ambiguity that German architect Oswald Mathias Ungers has isolated in his article on the Janus face of architecture: ‘architecture is, by its very nature, body of representation or container, figure or vessel, mass or void, core or shell, fabric or envelope.’ (Ungers 1991, 231)<sup>7</sup> Thus, architecture is most commonly either concerned with the design of walls, which contain space, or the design of volumes within walls. In each instance, architecture represents a form of thought about containing space, which has roots in an absolutist understanding of space. The idea of an absolute space has existed since ancient times, however, Isaac Newton elaborated this notion as homogeneous and endless space (Newton 1872). Absolute space is independent from action—it is pre-existent. Albert Einstein then intro-

6 For additional information on the Neue Nationalgalerie, see *New National Gallery, Berlin* by Vandenberg (1998).

7 My translation. German original: ‘[...] ob die Architektur ihrem Wesen nach Schaukörper oder Behälter, Figur oder Gefäß, Masse oder Hohlraum, Kern oder Schale, Stoff oder Hülle sei.’

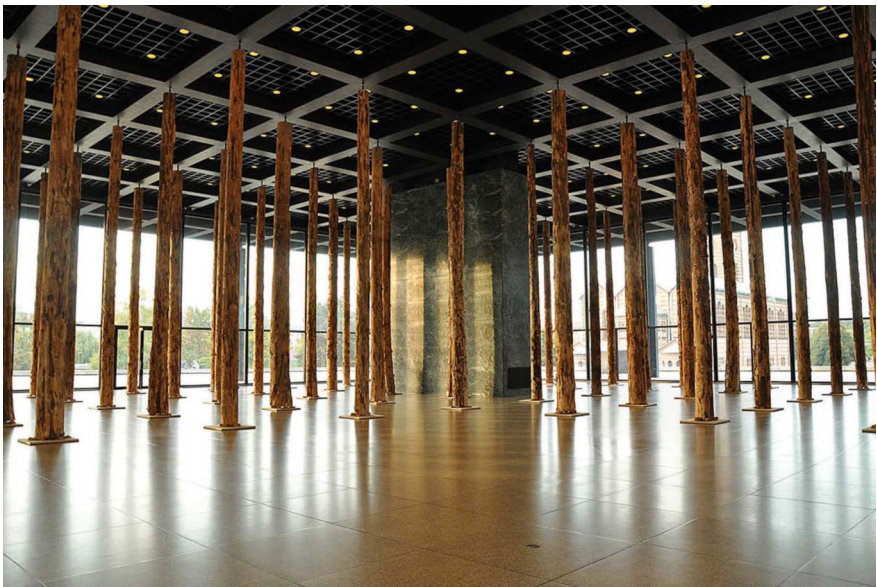


**Fig. 1.2:**

Isometric view. Junya Ishigami + Associates,  
KAIT Workshop, Kanagawa Institute of  
Technology, Japan, 2008.

**Fig. 1.3:**

Isometric view. Ludwig Mies van der Rohe,  
Neue Nationalgalerie Berlin, Germany, 1968.



**Fig. 1.4:**

Interior view (2014). KAIT Workshop.

**Fig. 1.5:**

Interior view (2014). Neue Nationalgalerie Berlin, exhibition *Sticks and Stones, eine Intervention* by David Chipperfield.

duced the term ‘container’ (as a negative demarcation from a relational notion of space) and ever since we have talked about ‘space as container’ (Einstein 1954, xv).

The term monospace originates from this very understanding of space as contained and to some extent can be considered representative of the difficulties that the entire architectural discipline has been facing for some time. As the Canadian designer and architect Bruce Mau has put it with respect to the major challenges civilisation is facing: ‘The problems we share are plural. Architectural practice and education, however, are still locked to the idea of the singular [...]’ (2004, 33) There are nuances to this. Indeed, some architects have started to address topics like ‘flow, mobility and transformation’ in their projects and have thereby turned away from ‘stylistic, formal, static spatial’ considerations (Lefaivre and Tzonis 2000, 58). Nevertheless, such ideas tend to stay *within* space and are seemingly unaffected by the current spatial discourse, a discourse for which we can learn from other disciplines.

In the wake of the *spatial turn* a vivid interest in space from the early 1990s onwards has permeated the humanities and social sciences (Soja 2011 [1989]; Döring and Thielmann 2008). Anthropologists and sociologists, for instance, describe how bodily self-perception has changed from a physical body as a container to an open immune system (Martin 1994); they have also addressed a new spatial understanding within the context of virtual networking (Löv 2001). With this awaking interest in the capacity to understand social phenomena through space, new concepts to investigate and theorise space were developed (e.g., in actor-network-theory (Latour 2005), practice theory (Schatzki 2002), sociology of space (Löv 2016)). Space turned into a complex social process, which can never be abstract, singular and enclosed by a shell. This should be enough of a reason to shift the focus and transform the field of a discipline involved in the shaping of space. Yet while we confront in recent decades in many spheres of life a change in spatial phenomena, this development has remained largely without effect in the field of architecture. There may be various reasons for this. The German trade journal of the Association of German Architects (BDA), *der architekt*, devoted a whole issue to the discussion of the spatial turn in architecture, stating that the discourse on space in the humanities has remained too abstract for architects and therefore had little effect on design (Denk, Schröder, and Schützeichel 2008). These authors consider architecture to be an object-oriented science, the reality of which has little need of such abstract theoretical approaches. Furthermore, as architect and academic Jeremy Till explains with regard to the task of the architect: ‘[t]he supposed neutrality of metric space provides a comfort zone in which dimensions can be shared as uncontested values [...]’ (Till 2013, 122)

Indeed, architects are entrusted with the planning of three-dimensional objects amongst other things. An absolute spatial thinking is linked to mathematical Euclidean geometry and Vitruvian architectural theory, which still today remains

the basis for dealing with the constructional parameters of the physical building elements (Hilger 2011). In this sense, architecture is concerned with a material spatial construction and thus preoccupied with a space that is contained in buildings. That architects can shape and control this space bolsters the authority of architecture as such. Accompanying this focus on the object, however, criticism begins elsewhere. Because it leads to

the dominance of aesthetics, style, form and technique in the usual discussion of architecture, and with this the suppression of the more volatile aspects of buildings: the processes of their production, their occupation, their temporality, and their relations to society and nature. (Awan, Schneider, and Till 2011, 27)

Excluding the processes buildings are part of, they are still understood as stable and rigid objects, which contain space. As such, they are widely designed, theorised and analysed, supported by a recursive architectural discourse (Hilger 2011; Awan, Schneider, and Till 2011; Latour and Yaneva 2008).

Nevertheless space offers the possibility of overcoming these limitations. Architecture must not be located *in* space and remain isolated from the course of action (Latour 1997).

Everybody knows—and especially architects, of course—that a building is not a static object but a moving *project*, and that even once it is (sic) has been built, it ages, it is transformed by its users, modified by all of what happens inside and outside, and that it will pass or be renovated, adulterated and transformed beyond recognition. (Latour and Yaneva 2008, 80; original emphasis)

Sociologist and philosopher Bruno Latour and architectural anthropologist Alben Yaneva programmatically demand the overcoming of the three-dimensional understanding of architecture in their article *Give me a Gun and I will Make all Buildings Move* (2008). What they propose is to integrate the numerous dimensions, processes and relations in which a building lives into the (spatial) understanding of architecture.

In the following study, I pursue the demand for earthly accounts into a ‘building-on-the-move’ made by Latour and Yaneva (ibid. 87), and turn to the process of spacing as a way of exploring the multiple dimensions of the monospace. What such an approach prioritises is the rich life buildings possess in reality. Exploring the monospace as a field of possibilities with the help of actor-network-theory (ANT) (Latour 2005), this book aims to enrich the understanding of (architectural) space as a complex process emerging out of the shared agency between architects,

buildings and the people who occupy and use them. ANT, as it is rooted in science and technology studies (STS), is a method of inquiry that allows us to re-conceptualise architecture from an experiential perspective. Appropriating the term ‘spacing’ from Bruno Latour (1997), the focus of this study are the consequences of a symmetrical processual approach to space (as rooted in ANT) for the understanding of architecture and its relations. Concentrating on the process of spacing instead of discussing its nominal form ‘space’, allows us to witness the emergence of space in activity. Actors here are humans as well as materials, objects, techniques, texts, norms, etc. that form networks with other actors. The power to act is distributed within these networks and can therefore never be attributed to a single actor alone. With spacing, space is no longer singular and no longer contained but actively created during multiple interactions: between objects, materials and humans. The term monospace is thus misleading, as there is not one homogeneous space but a complex and rich variety of temporally limited spaces generated *in* and *through* action. For this reason, I focus on the ‘doing in common’ of architecture and people. In other words, I analyse the shared process that takes place between people and a given building. Hence I abandon the still predominant static and passive understanding of architecture. The monospace *in* space turns out to be a ‘multiverse’ with spacing.<sup>8</sup>

## 1.2

### A Realist Account on Architectural Space

In foregrounding interaction, practice and experience I follow a host of different scholars who are concerned with moving past the traditional divide between active subjects and passive objects, mind and matter (Mol 2002; Latour 1991). Some of these scholars have been particularly concerned with architecture as well. There is a turn towards design and architecture *in the making* (Loukissas 2012; Houdart and Minato 2009; Yaneva 2005b, 2009b, 2009a), as well as a shift in the approach to architecture that *is made* (Yaneva 2012, 2013, 2017). Albenya Yaneva who introduced ANT into the field of architecture, demands a ‘dynamic understanding of build-

---

8 On reading an article by Albenya Yaneva *A Building Is a “Multiverse”* (2005a), I was inspired to take up this term. Also Latour and Yaneva speak of ‘a complex and multiverse argumentative space’ (2008, 87). The term was originally coined by American philosopher and psychologist William James (1895, 10). Camacho-Hübner and Latour explain it elsewhere: ‘Since there is no good accepted term—which in itself is odd since it is the only world we all inhabit, human as well as nonhumans!—we will use James’s term, *multiverse*, indicating by this word that it is indeed just as real as the ‘universe’ of commonsense but that it has not been prematurely unified through a continuous “physical space”, in effect the *res extensa*.’ (November, Camacho-Hübner and Latour 2010, 595; original emphasis)

ings' (Yaneva 2010, 142). 'Realist accounts of architecture are to be made in a situated and pluralist fashion' she notes and claims that 'if we really want to understand the meaning of buildings, we need to [...] make a detour to practice.' (Ibid. 145)

The interest in practices is not new. There is a broad turn to practices within the social sciences and humanities (Schatzki, Knorr-Cetina, and Savigny 2001; Reckwitz 2003).<sup>9</sup> In the field of social and cultural geography, Jane M. Jacobs and Peter Merriman introduce the concept of 'practicing architecture' to elaborate an understanding of 'architecture *in practice*' (Jacobs and Merriman 2011, 211; original emphasis). This includes various architectural actors from the process of creation and occupation, change or manipulation to decay and dismantling. These actors are not only human but also include animals and insects as much as processes and forces like weathering and rusting. In this way they 'wish to animate architecture' and understand it 'as an on-going process of holding together [...]'. [T]he stable architectural object (architecture-as-noun) is turned into an 'effect of various doing (architecture-as-verb).' (Ibid. 211–12)<sup>10</sup> However, there is 'no unified practice approach' and while

most practice theorists would agree that activity is embodied and that nexuses of practices are mediated by artifacts, hybrids, and natural objects, disagreement reign about the nature of embodiment, the pertinence of thematizing it when analyzing practices, the sorts of entities that mediate activity, and whether these entities are relevant to practices as more than mere intermediaries among humans. (Schatzki 2001, 11)

To what extent the world divided into lifeless matter and active life should actually be left behind thus remains contentious ground. Current practice-oriented accounts of space, such as Theodore Schatzki (2002) and Martina Löw (2001), while acknowledging materiality in their ordering capacity in social spatial production, nevertheless give (in different ways) preference to human action.<sup>11</sup> Even if current scholarship interested in architecture investigates 'the doings of built spaces' (Reh and Temel 2014), considering relational, processual and practice based architectural experiences (Leuenberger 2018), there is nevertheless some kind of partiality

---

9 On ANT as a 'stringent' sociology of processes see Laux (2011).

10 See Jacobs and Merriman also for an introduction into the literature on geographies of architecture (2011). They emphasise that '[m]uch of the existing geographical scholarship does stay resolutely interested in this human-centred view of architecture: its users, its producers and (re)designers, its meanings.' (Jacobs and Merriman 2011, 218)

11 Schatzki distinguishes two types of action, one of which is intentional and thus a distinctive feature of humans (Schatzki 2002). Löw on the contrary stresses the aspect of human synthesis as an element of the constitution of space (Löw 2001).



given to the subject. The same can be said of the accounts that begin from the co-production of atmospheres (Böhme 1993). This is indeed something that pushes the boundaries to overcome the subject-object dichotomy in space. That said, such accounts ultimately stress an intentional, reflexive, perceiving subject and/or its biographical vantage point. In general, studies that not only make a discursive contribution but also move into material reality are scarce. This has been pointed out by architectural theorist Hilde Heynen as well as sociologist Martina Löw (Heynen 2013; Löw 2001). The present study wishes to address the current gap in the literature through exploring the potential of an ANT-perspective approach, which is a different way of looking into the realm of (architectural) space.

Following humans and nonhumans by means of ANT is to approach them symmetrically.<sup>12</sup> In this way it will be possible to circumvent the predominant mode of assessing such things through the principally human-centred perspective on a given course of action. I claim that this approach to reality is particularly revealing for architecture's concerns. Here, it is not the point to 'catch reality as it really is. Instead it is to make specific, surprising, so far unspoken events and situations visible, audible, sensible.' And hence 'to attune to reality differently.' (Mol 2010, 255) What ANT offers is the possibility of showing the difference things make and tracing their social life. It will thus provide a way of including buildings in social space, but a social space that is as much non-physical as it is physical and that distributes agency without separating these two domains. Quite simply, agency emerges through the doing in common of people and architecture. Latour refers to the social then as '*a type of connection* between things that are not themselves social.' (Latour 2005, 5; original emphasis) When 'faced with an object', he explains, we should not aim to explain it through 'social aspects surrounding it' but 'attend first to the associations out of which it's made and only later look at how it has renewed the repertoire of social ties.' (Ibid. 234) While STS-inspired approaches in the field of architectural research produce(d) rich accounts into design practice we can find scholars in the field of cultural geography who discuss (architectural) space under its influence (Thrift 2006; Murdoch 1997, 1998). The work of Kevin Hetherington is of particular interest here since he addresses the relationship between material culture and spatiality in the context of a museum setting, which will be the empirical setting for this study (Hetherington 1997).<sup>13</sup> This study therefore takes up influences from an interdisciplinary field of research at the intersection of anthropology, sociology and cultural geography. It takes its inspiration from such work and wishes to convey it to the spatial discourse of archi-

---

12 Speaking in the following of the pair human and nonhuman I follow Latour's concept which is 'not a way to "overcome" the subject-object distinction but a way to bypass it entirely.' (Latour 1999b, 308)

13 For research into spacing and timing in relation to organising see Jones, McLean and Quattrone (2004).

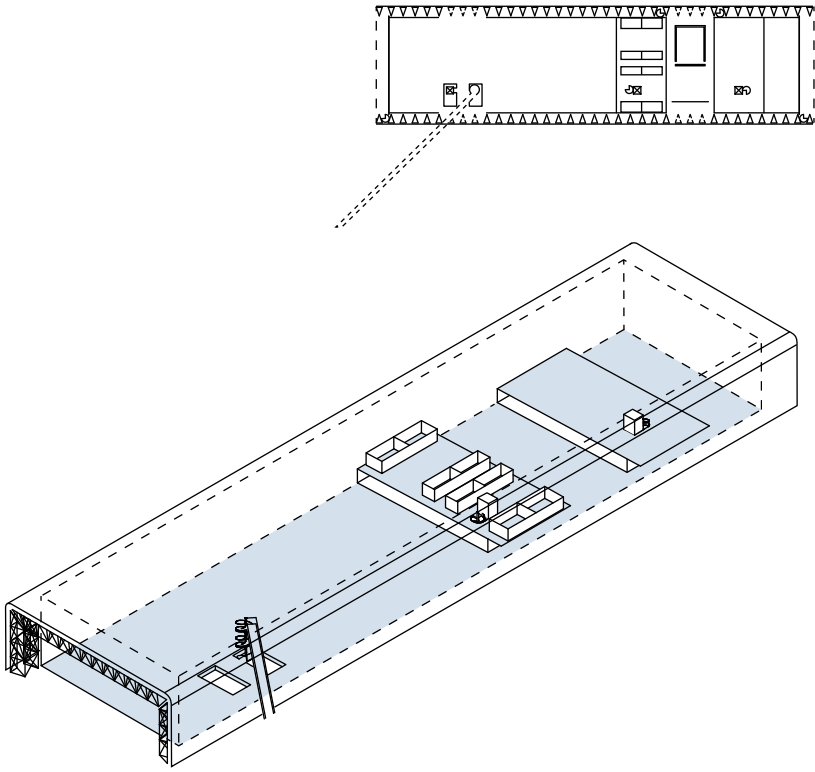
tectural theory. Turning my attention to the typology of monospace, I argue that an absolutist-substantialist understanding of such space particularly obstructs the ability to grasp the reality of these types of building. The built structure of a monospace is essentially a shell. If we fail to address the processes along with the building itself, then we have no access to the real complexity, to the tangled and messy reality of these buildings.

This book engages with a specific building located at the edge of the campus of the University of East Anglia (UEA), in Norwich, England by Foster Associates (Fig. 1.6, 1.7).<sup>14</sup> The Sainsbury Centre for Visual Arts (SCVA) opened its doors in 1978. From the outside, it is a white tube with a prominent steel framework at both ends oriented into the greenery. It houses, under one single outer shell, several different institutions and activities: the university's art gallery, a café, restaurant and shop, the School of Art History and World Art Studies and the Sainsbury Research Unit. As the architects of the building Foster and Partners put it, the Sainsbury Centre 'integrates a number of relative activities *within a single, light-filled space*' (Foster + Partners 2018; emphasis added). Is it indeed just a *single, light-filled space* that contains activities? How can we have access to the relationship between architecture and the manifold activities that emerge with it? The literature provides little insight here. From the existing accounts of this building we do not understand what this specific building does, how it fosters, hinders or supports in particular ways the daily life of the Sainsbury Centre.

Since the case study is concerned with a building of a so-called star architect and as I am speaking about 'architectural' space one could easily assume that this study is occupied with high style architecture. However, in the following it will become evident that this study is in no way preoccupied with stylistic architectural pretensions. On the contrary, the research is about 'mundane' processes—that is the understanding of the word as something earthly or worldly—that arise with buildings. Since space here is to be discussed as a complex ongoing process with buildings and people, I am not using the term 'built' space as it echoes a discrete/complete object. I am an architectural theorist and researcher and my alliance is with architecture, however, my approach to this building is hybrid. I will first introduce it in the tradition of architectural description and analysis. I will thus start from common ground only to then draw on the method of ANT in order to trace and analyse the way space emerges in the course of action. Ethnographies of architecture as conducted into the field of architectural practice (Houdart and Minato 2009; Yaneva 2009a, 2009b) have shown previously how ANT helps to analyse the entanglement of the world of the office and architects in the making of buildings.

---

14 Foster and Partners proceeded in the 1990s the office Foster Associates, that was founded in 1967 by Wendy Cheesman and Norman Foster. In the following I will only speak of Foster and Partners also addressing the work of Foster Associates, unless explicitly touching on historical circumstances.



**Fig. 1.6:**

Isometric view. Foster + Partners, Sainsbury  
Centre for Visual Arts, University of East Anglia,  
Norwich, England, 1978.



**Fig. 1.7:**  
Interior view (2017). Sainsbury Centre for Visual Arts.

I take this approach up and enhance it with specific types of interviews: sketching and walking interviews.

ANT is increasingly recognised in the field of architectural theory (Hauser, Kamleithner, and Meyer 2013, 2011; Crysler, Cairns, and Heynen 2012); that said, it shakes architecture's belief system in that it relocates architecture's agency in networks. Using the ANT methodology in this study to focus on the doing in common of architecture and people, analysing the shared processes that take place between human and nonhumans, means generally leaving dualism or the modernist opposition between subject and object behind (Latour 2005). This results in the disempowerment of the genuine creator of objects who acts upon the 'user'.<sup>15</sup> Here, the architect is one amongst many spatial creators. Turning to the building in practice and tracing the process of spacing allows us to enter the complex and mutual connectivity between architecture and the social, which is of particular concern to current interdisciplinary scholarship.

### 1.3

## A Current Debate: Architecture and the Social

The concept of spacing is not only important in terms of how we conceptualise space in architectural theory, and how we analyse and understand buildings, it also implies a careful re-thinking of traditional ideas about the role and relation of the architect and the people engaging with a given building. In this respect, the Sainsbury Centre is an excellent example. In the first instance this is because its multi-functional uses create a rich inner world of different courses of action. Secondly, it is a building that is considered to be highly modernist. As many architects of his time, Foster assumed his buildings to have a structuring and changing impact on society (Sudjic 1986). Turning to the Sainsbury Centre in practice and drawing on a non-modernist methodology (ANT) is a way of breaking with convention. Since ANT takes a non-deterministic stance on the relation between subject and object, interesting shifts and valuable insights can more easily emerge, which will allow for a re-thinking of the architectural relation: between the building and the social. It moves the focus of interest from the three-dimensional static object in architecture to spatial structures that act latently; it relocates the architect as the supposed

---

<sup>15</sup> The 'user' as a modernist term has a functionalist connotation. He/she is an abstract person, unknown to the architect and without phenomenal identity (Forty 2004, particularly 312–15). I prefer in the following to speak of 'people' or 'humans', whenever not addressing the modernist understanding. While people and humans in the first place are indefinite designations they can be enriched with specific roles, capacities, and experiences without implying a functional relation to buildings.

genuine shaper of space into a complex network of shared agencies in the making of space. Here architecture's relations are re-arranged, which allows the work to contribute to current debates on the relation of architecture to the social.

In the course of the rediscovery of space with the *spatial turn* there is also an (re-) awakening of an explicit interest in architecture within disciplines such as sociology, anthropology and human geography (Delitz 2009a; Yaneva 2009b; Jacobs and Merriman 2011; cf. also Heynen 2013). During the last fifteen years, lively research has been conducted in the field of architecture, which explicitly addresses architectural artefacts, activities, and discourses.<sup>16</sup> Here, we discover scholars who try to leave traditional determinist concepts, which view architecture either as a mirror of society, assuming 'that buildings [...] are essentially social and cultural products' (King 2003 [1980], 1) or as a tool to produce and shape social life (as e.g. discussed by Evans (1982) with regard to prison architecture). Both of these perspectives are reductionist, as Yaneva argues (2012, particularly 25–37). It is this very separation of social human space and physical object space, which prevents understanding the complex entanglement of both. As long as we take the monospace building as a solid object, which contains space we cannot have access to its processual nature and cannot acknowledge what it does. Yet, thinking architecture and the social together does not mean putting them into causal relation and asking 'who or what shapes/determines/organises who or what'. This merely re-produces two distinct domains, reducing the relationship to a linear process. On the contrary, a non-deterministic stance, as suggested by ANT, allows for the circumvention of traditional disciplinary boundaries, which separate the architectural object from the social. This is a very promising approach as it allows us to address the entanglement between humans, objects and buildings in the field of architecture. That said, taking this interdisciplinary path shakes beliefs within the discipline of architecture as it touches on the authority of architecture as such; it questions architectural agency and re-arranges the relation between the architect and people engaged with buildings-in-use.

Modernism particularly tied the design of the architectural object to the claim to have an effect on the 'user'. Through the architectonic 'programme' (Summerson 1990), Modernism attempted to define spatial relations with regard to functions.<sup>17</sup> Here architecture's agency is used to *operate* the social, which builds

---

16 Next to the aforementioned ANT-inspired studies into the realm of architecture one strand here is the Sociology of Architecture, an association founded in 2007 within the German Society of Sociology. Building on a range of sociological classics this association aims at creating a new discipline including the development of its own theory, methodology and research (Delitz 2010, 2009a). But also in the field of human geography, the Geography of Architecture follows an explicit interest in studying the architectural realm (Cresswell and Merriman 2011).

17 Following the definition of Summerson, the programme as a principle of spatial design works in relation to specific functions: 'A programme is a description of the

on the dualism between the ‘social’ and the ‘architectural’ or the ‘human’ and the ‘material’. Architects tend to believe that their work is a means of improving and enriching social conditions, which ‘assures them that their work has value reaching beyond the mere provision of shelter.’ (Lipman 1969, 195) While studies in the 1960’s and 70’s attested to the strong deterministic belief system driving architects (Broady 1972; Lipman 1969), the ‘belief in the moral authority of architect’ is less explicit today (Hill 2003, 8).<sup>18</sup> There have been clear counter-movements aiming towards a less functionalistic understanding of the user. This is particularly evident with participatory architecture that specifically addressed the housing situation after the second World War as we can see for example with the work of John Habraken (1972), or the approach of Herman Hertzberger (2009 [1991]). The latter sees architecture as means of emancipating the user to a dweller. Notwithstanding the sensitisation towards knowledge and the diversity of individuals and communities, even today ‘the hierarchy of architect and user is evident in the discourse of architects’, as the architectural historian Jonathan Hill diagnoses (2003, 9).

‘As author, the architect has *authority*, which at the same time is a prerequisite for one’s credibility as a professional.’ (Schneider and Till 2009, 97; original emphasis) Nevertheless, the architect as a genuine, autonomous designer-architect has recently come under scrutiny. The increasing globalised star system creates celebrated singular authorships (McNeill 2005)—Foster is mentioned here in the same breath as Frank Gehry or Zaha Hadid. In the course of highly complicated construction processes, economical and legal demands, this is romantic fiction and a new picture must be drawn to show the architect’s dependencies:

These buildings are not and cannot be exemplars of the architect’s autonomous application of knowledge and talent alone. They are also striking manifestations of the architect’s dependence on clients and other specialists of building, be they rival professionals or humbler executants. I call this dependence *heteronomy*, because it contrasts radically with the autonomy that is always considered a defining attribute of professional work. (Larson 1995, 5; original emphasis)

However, it is not only the clients, the countless planners and specialists, who are involved with a building in the making: the *dependence heteronomy* extends much

---

spatial dimensions, spatial relationships and other physical conditions required for the convenient performance of specific functions.’ (Summerson 1990, 263f.) Architectural historian Adrian Forty points out that we need to be aware that ‘The identification of a theory of form-function relations only appears after 1960, [...] as part of the general attack upon modernism’ (Forty 2004, 187).

18 See also the early studies into architectural practice which also shed light on the architectural belief system by architectural theorist Dana Cuff (1991) and sociologist Judith Blau (1984).

further. Turning towards the mundane practices in the architectural offices, complicates the situation even more. It becomes apparent that the design process is not only a 'co-operative activity' of humans but 'models, paints and pixels, material samples and plans' alike, as Yaneva shows (2009a, 12). Yaneva followed and described the daily practices in the architectural office of Rem Koolhaas (Yaneva 2009a, 2009b). The coming into being of a building emerges out of innumerable small routines and design moves. However, what is involved here is not simply a displacement of the architect from the focus of attention. Rather, Yaneva suggests re-positioning the architect as the 'setter of a specific studio practice; his buildings are born in the studio world' (Yaneva 2009a, 102). Architecture 'depends', as architect and academic Jeremy Till (2013) discusses, not only in the making, a process that involves many others during construction, but also in its occupation afterwards by many others. Thus, not only the architectural processes of designing, negotiating, presenting and re-thinking are involved in making a building but also processes that involve other actors, which in some respect call the position of the autonomous architect into question. Suffice to say, such issues create complex authorships. Looking at things from the building in practice perspective challenges the genuine position of the architect as authority. Here, accounts on 'building conversion' (Guggenheim 2010), post-occupancy re-design (Brand 1994) or the retrofitting of a laboratory building (Gieryn 2002), show how in the life of a building spatial structures change and can overwrite the architect's plan. Turning to spacing, however, this study rather reveals the being *with*, the mundane entanglement between people and objects and the building; it particularly looks into the details of the messy reality. Here not only many small modifications of spatial arrangements come to the fore, but also the work that is necessary to hold things together. Similar things can be discovered in studies of maintenance and repair (Graham and Thrift 2007; Strebel 2011), but also in the concept of architecture as a 'manifold interface' put to use (Guggenheim 2010, 7).

The Sainsbury Centre for Visual Arts is a museum and education centre. While my focus is on spacing I trace many practices that are specific to museum environments, for example object visitor interaction. In the broad field of museum studies we likewise face (in addition to the aforementioned) a growing awareness of 'multiplicity and complexity' (Macdonald 2006, 2). Here we encounter a specific tension with a museum's aim towards the creation of some kind of homogeneity (Hetherington 1999). Social anthropologist and museum studies scholar Sharon Macdonald describes the museum as 'institution of recognition'. 'It selects certain cultural products for official safe-keeping, for posterity and public display—a process which recognizes and affirms some identities, and omits to recognize and affirm others.' (Macdonald 2006, 4) This process of ordering goes hand in hand with the design of 'architecture, spatial arrangements, and forms of display as well as [...] discursive commentary—of fact, objectivity, superior taste, and authoritative



knowledge.’ (Ibid.) That said, the museum as a site of knowledge creation (Hein 2006) has been recently discussed in terms of a shift from a place of authority to one of mutuality (Hooper-Greenhill 2000). Contemporary explorations of new relationships between visitor and exhibits (T. Smith 2012), and the turn towards museum objects and materiality (Dudley 2010) go beyond more traditional concepts of museum as (cultural) ‘contact zone’ (Clifford 1997, adapting this concept from Mary Louise Pratt). Hetherington points out the ‘clear and unique perspective on the museum’ that ANT in this context allows for (Hetherington 1999, 52). His ANT-inspired relational perspectives into museums show how even this place of classification never is under full control (Hetherington 1999). Hetherington traces the idea of heterogeneity along a shifting relation between subject and object as established by museums over time. Discussing how museum objects, such as Marcel Duchamp’s urinal challenge the idea of an orderly and knowable world, which the modern museum as it occurred in the second half of the 18th century aimed for, Hetherington draws a comparison to contemporary philosophy and ANT. With Hetherington we can learn how objects, urinals as much as ceramic owls, create ‘fold[s] in the *Euclidean space* of the modern museum’ (Hetherington 1999, 69, 1997). Concerned with the Sainsbury Centre, this study then approaches the museum building (amongst others) with the help of ANT. It rarely goes into detail with specific pieces of art, but rather traces the many others that are present when it comes to visitor object/visitor building interaction and other processes as well. As such the focus of this work remains within a broader discussion of spacing as fruitful for a different understanding of architecture, providing valuable insights into museum practices. Turning to an object rich world by following spacing in the specific context of the museum setting allows for a contribution to be made to current attempts for a more complex and rich understanding of museums. Additionally, my specific account of visitor experience traces immediate encounters in object interaction, a surprisingly underexplored area in the field of museum studies.<sup>19</sup>

---

19 Social and material anthropologist Sandra Dudley who focuses on bodily sensorial (subjective) experience with museum objects points out that the physical engagement with material things have often been disregarded even in the field of material studies (Dudley 2012, 2010). Also Kirchberg and Tröndle (2012) who have also reviewed the studies of visitor experiences in museums, emphasise that this topic remains underexplored in much of the recent literature in the field of museum studies. Summarising visitor studies of exhibition experiences that are empirically based Kirchberg and Tröndle, highlight the similarity of these studies in a ‘general idea of chronology and causality’ (ibid. 447). Pointing out that these studies all, except for one, were ‘pre- or post-visit surveys’ based on questionnaires they highlight the lack of studies into the immediate visitors experiences itself (ibid. 448). Generally speaking, a more nuanced view of visitors is developing, however, this shift away from a homogeneous ‘public’ in museums is ‘still only patchily achieved’ (Macdonald 2006, 8; Falk, Dierking, and Adams 2006).

This study aims to provide a realist account of space in the field of architecture: neither reducing architecture to material or technology nor humans to simple user. I thus wish to trace the rich reality of a monospace building, and the specific reciprocal relationships between practices, objects, materials and humans to deepen our understanding of the relation between architecture and social life. Validating research methods by ‘studying through experience’, I will contribute a valuable analysis to current architectural discourse. This follows the postulates of a new field of architectural practice (Awan, Schneider, and Till 2011), and current attempts to extend the concepts of architecture and architectural theory (Hauser, Kamleithner, and Meyer 2013, 2011; Crysler, Cairns, and Heynen 2012). Beyond this field of interdisciplinary architectural research, I will add to ANT-inspired anthropological works on architecture in general and in this field furthermore to research into museum environments.

## 1.4 Structure of the Book

The monospace urges us to rethink our understanding of space within architecture and to question our understanding of what architecture is and what it does. How does a building, its layout, objects and materials contribute, promote, hinder or change spatial processes? How can we refrain from understanding a building as a stable and passive object? How can we trace the mutual entanglement of practices, objects, materials and human bodies within the world of a building in use?

I begin with an overview of the typology of monospace and present it as a specific form of the open plan building (Chapter 2). Understanding a monospace as a physical object seems simple—a box that contains space—however, this does not do justice to the reality of monospace buildings in use. Arguing that space can give access to the mutual entanglement of monospace buildings with social life, I open up a theoretical discourse on space. As an absolutist-substantialist concept of space excludes the buildings from the courses of action that take place within them, I consider the theoretical foundation and positions that apply to relativist-relationalist concepts of space as currently often employed in the field of sociology. To make sense of the multiple connections that occur between space and practices, objects, materials and human bodies, I then turn to ANT in order to be able to neither focus on the physical built environment nor on the social life in courses of action, but to gain a view ‘in-between’. I lay out the terms of actor, agency and network as they are rooted in ANT and which are essential for including objects into processes of spatial production. On the basis of this theoretical foundation, I conclude the chapter with an outline of the empirical analysis.

Turning to the Sainsbury Centre for Visual Arts, I first explore the building with an architectural description and then provide a glimpse into the available literature (Chapter 3). How does this specific monospace look, and what enables the large spatial volume? Approaching the Sainsbury Centre as a monospace implies adding another reference system to a building that has been put into many contexts previously. However, instead of applying another rigid and static framework to the Sainsbury Centre I take this building type as a point of departure and place of arrival simultaneously. During the analysis, a careful examination of the world of the Sainsbury Centre with the help of ANT (Chapter 4–6) provides an understanding of what a monospace is. This shifts from the formal-typological to a nuanced understanding of its possibilities and dependencies by means of a realist account. A monospace will be what it does. This generates a typology in flux—a typology we can only understand from ‘within’ and which thus focuses on the becoming (of space) (Geipel and Hansmann, forthcoming).

Thus, following the processes and practices *with* the building we leave the idea of a beautiful and static object that resides *in* space behind. Based on interviews and ethnographically inspired accounts we turn to the building ‘in practice’. This is where we can witness the entanglement of architecture and all its elements with people. ‘In practice’ permits the discovery of the ordinary and the exceptional—mundane problems, contradictions, ephemeral and long-term decisions—*with* the building, and thus with the elements integral to spacing or specific spacing processes themselves. Firstly, we take a walk through the building with the Head of Collections and Senior Curator (Chapter 4). Structured along three stops, we follow our guides and listen to the staff of the Sainsbury Centre Institute who introduce different modes of *working with* the building. Working-with is a sharing of agency with the building in spacing. This chapter allows us to follow and unravel the connectivity between architecture and people. Through its analysis we will see that both people as much as objects can act in unpredictable ways. With the help from STS and ANT scholars, we will learn to differentiate the ways they jointly engage in spacing, both in terms of material arrangement and in terms of courses of action. We will witness how the building begins to move and change when we approach the world of working-with and how the building as a fully blown actor entangled in spacing becomes visible.

Equipped with a clear understanding for how exploring the world of a building from *within* always opens the complexity of that very building in reality, we then move on and turn to the experiences of people who are engaged with the Sainsbury Centre, albeit only temporarily (Chapter 5). Once more we do not turn our attention to the objective or the subjective perspective. Approaching the rich and ephemeral state of flux involved in spacing we look into the possible contributions of a specific form of interview. Asking interviewees to sketch while answering questions about their stay at the Centre we see how many objects, materials and practicalities

come to light by means of this tangible activity. We witness how the building is perceived, practiced, and experienced. While spacing circuits the distinction between subjective and objective it also challenges any determinism tied to functionalism. Hence, we also add that it equally rejects the reductionist understanding of the 'user' in architecture as much as of the 'public' in the museum. Various experiences simultaneously coexist with the building, as it is manifold in its possibilities of allowing, hindering, and fostering certain courses of action.

Along with specific experiences of light we then move deeper into the world of the building itself particularly focusing on the various contributions of objects and materials in the work of spacing (Chapter 6). Light is a controversial issue in the context of museum buildings and it was in a state of re-negotiation during my research at the Sainsbury Centre. Following the many *spacing devices* in the complex networks involved in the making of light, we learn about the specific quality of objects that bridge times and locations. Furthermore, interactions are always made of different materialities. In tracing the making of light we can witness the complicated nature of spacing. Space is made with materials, objects, technical devices, rhythms, etc. and it is the reciprocal relationship between space, building and humans that becomes visible when tracing the connective power of light.

The final analysis then brings the results of the study together, discussing the findings and their significance for architectural theory and practice and their pertinence for current debates about the relationships between architecture and social life (Chapter 7).

## 1.5 Writing Style

Monospace buildings are often dismissed as non-functional. I do not aim to criticise or to defend such buildings. What I attempt rather is to engage with the world of the building in order to trace its multiplicity. In so doing judgement is not my concern. By means of detailed description, we will approach the world of the building to unravel the mutual processes of spacing, following the constant work that is involved in the making of space. Thus, while my text is argumentative when considered theoretically and methodologically, it is rather reflective in terms of the presented case. Methodologically, because I try to open up spatial processes and show how we, as architectural theorists, using our own analytical repertoire, and utilising ANT, can access such processes. Thus, I am concerned with a way of thinking and approaching space and its implications for our understanding of what architecture is and what it does. To use this technique to judge buildings or to employ it for prospective designs I leave open for the future.

Using the first person singular, the 'I', is uncommon in Germany in the context of academic writing; on the contrary, in an English setting, it is used frequently enough. But there is another reason why it is tricky to use the 'I' in this work. It could suggest an auto-ethnographical stance that hints at a phenomenological approach, which I particularly chose not to follow, as I will explain in more detail (Chapter 2). Nevertheless, I do use the first person singular. Not to make myself more important than necessary, but to make myself visible as an actor in the spatial processes I observe and participate in. Thus, I wish to acknowledge that I myself am an actor in this work. In contrast, I address an academic distant narrative using the 'we'.

A final word on the use of images. Images can neither represent experiences nor convey their sequential character. They reduce, separate and freeze a course of action, a moment in time and convey rigid impressions. Furthermore, they focus on the visual sense. However, of course images are a central component in the production of architecture as well as in architectural analysis. Therefore, I pursue three strategies when using images in this study. Firstly, I follow architectural tradition in presenting the building through a variety of drawings. There can be no single drawing that shows or makes the whole building understandable, but rather a multitude of drawings in combination with pictures. Secondly, I use isometric drawings and annotate them with links to specific text passages with detailed descriptions. In this way, the drawing becomes a navigational tool that allows the reader to travel to different dimensions in order to explore the complexity of the building.<sup>20</sup> Thirdly, I use a series of picture, fragmented images and snapshots that accompany ethnographically based chapters. Such sequences have no separate textual explanation prior to the ethnographically inspired account. I do not wish to reduce the abundance of visible things to a caption simply to focus the reader's attention and guide them. There is no simple way of knowing a building.

---

20 Using the annotated drawing as a navigational tool is inspired by the discussion of (navigational) maps in the field of geography, which was suggested by November, Camacho-Hübner and Latour (2010).



## 2

# Opening the Box

---

In the following, I will introduce the typology of monospace,<sup>1</sup> a specific form of open plan architecture, and argue that monospace urges us to re-think our bodily relation with and theoretical approach to architecture. The question of space is central to this. That said, this is not about a philosophical discourse on what space is and what not but about contrasting the prevailing notion of space in architecture with spatial models from the social sciences and humanities. Finally, it is about showing which consequences arise when approaching this type of architecture with the ANT methodology.

Architects most commonly follow a traditional spatial understanding. According to this approach, space is what is contained in a building (Hilger 2011; Till 2013). The term monospace, too, refers to such a three-dimensional container space, which roots it in an absolutist spatial understanding. However, architects are also aware of the complex relations between *their* buildings and the social, not least because they have to meet all the contradictory demands and parameters that shape a building in the course of its design. In addition, after structural completion, buildings are subject to complex processes. To some extent architects try to anticipate or to structure and even define the forms of living interaction made possible by their buildings. Thinking buildings and people together thus is not alien to architects. Some scholars even argue that this is the basis of the architect's authority as it creates social and political relevance (Lipman 1969). In relation to the prevailing spatial concept, however, it is certainly subject to contradiction since sociological spatial categories are excluded or set in relation to causal relationships in absolutist spatial models. As I believe, it is particularly indispensable with monospaces to think a more complex mutual interrelation between people and building. This is necessary to understand their 'doing' together, not only of people and building, but of all the different devices that create the world of a

---

1 Thoughts on the potential for a typological classification and designation that allow fundamental questions about the nature of architecture and its relationship to space and social life have also been published in the article *Über Hüllen und Werden* (Geipel and Hansmann, forthcoming), which draws on this chapter.

specific monospace. To do so, it is fruitful to include the insights of current anthropological and sociological research. In the latter, we find a way into the shared ‘doings’ that thus turn away from the separation of objective, passive, stable material or subjective, active space (Latour 1997). It is in this ‘doing’ that space is constituted, that the architectural quality emerges, and that we can understand what difference a building does. This is something that is neither contained in the plan nor visible on high-glossy prints of the façade: it is present in the ‘social life of a building’.<sup>2</sup> We will thus explore the concept of spacing and shed light on the implication it has for our understanding of the concept of agency before introducing the components of the inquiry and laying out the specific methodological choices for approaching the lived reality of the Sainsbury Centre in the next chapter.

Before going into a brief introduction of the typology of monospace and the many concepts that we can group around it, let me provide an initial note on the use of the term space. ‘In the hands and minds of architects, space is generally emptied, and with this is made available as something that can be directly manipulated as some kind of stuff.’ (Till 2013, 118) However, in the use of the term space, as Till further notes, it is not always clear whether what this implies is physical or mental, an actual condition or metaphoric notion. Delving into the world of monospace, I leave this vague use of the term space without comment. By the end of this chapter, however, we will have gained more clarity and capacity to draw distinctions.

## 2.1 Open-Plan and Monospace

In the late 1980s an advertisement for the *Renault Espace* appeared, a large limousine with seven seats where passenger and luggage share one space without a separate trunk. A few years later the *Renault Mégan Scénic* with removable back seats was introduced with the epithet *Monospace*. In the field of architecture these vehicles have been a source of inspiration for the term monospace. Influenced by the idea of a flexible internal space that allows for various uses in changing constellations, the architect and urbanist Finn Geipel and his colleague Nicolas Michelin took this term up in the context of their project Nîmes Arena (1989), France. No longer addressing a small mobile unit of space but describing one-room-architectures distinguished by a maximally open floor plan with one all-encircling shell,

---

2 Speaking of ‘a social life of buildings’, I follow Yaneva’s work (Yaneva 2009b, 2012, 2017) who shows how ‘A building is not a static entity composed of symbols, but a flow of trajectories.’ (Yaneva 2012, 20) In the use of the term, Yaneva references Arjun Appadurai, who argues in his study about commodities and the exchange of values, that things, like people, have a ‘social life’ (Appadurai 2013).



Geipel, concerned with the aspect of transformation and openness, experimented with this concept in various subsequent projects and in his academic teaching (Geipel, Koch, and Thorwarth 2011; Place 2000).<sup>3</sup> The typology of monospace in the broad field of open plan architecture is a comparatively small group of buildings. I suggest understanding monospace as a radical case of open plan architecture: the boundaries between the two are fluid. One distinguishing feature is the single-storey or multi-storey design. The floor plans alone do not necessarily allow a distinction to be made.

Although the term monospace is a recent one, the history of such buildings is not tied to any particular period; similarly, it is not subject to any specific culture, size or function. Already in the Stone Age caves or the itinerant dwellings of early hunter-gatherers or pastoral peoples are characterised by open-plan layouts, most of them comprised of only one room. Thus, from the outset, monospace can be described as an early or primitive typology, which can be found on every continent.<sup>4</sup>

Monospace structures are built to this day and there are various motives for using this supposedly primitive type of building. Public and cultural uses take advantage of the large single room, which allows for substantial gatherings. Early examples are the Pantheon in Rome (119/125–128 AD) with its domed rotunda that was built as a temple dedicated to all the gods and later converted into a church for assembling the community (MacDonald 1981). Another example are the Roman basilicas which had been used originally as places of business and legal matters (Platner 2015, 71 ff.). Additionally monospaces are used for sport activities and events as well as serving as places for production. They create vast and continuous spatial layouts—economic aspects, as well as visibility, play an important role here.<sup>5</sup> The last examples could also be viewed under the title ‘supersheds’, which author and architect Chris Wilkinson defines in his eponymous book as ‘buildings enclosing a large single volume of space with relatively long span and without major subdivision’ (1996, xi). Wilkinson explains that supersheds belong to a group of buildings that ‘has largely been excluded from the mainstream of architectural classification, and left to the province of engineering’ (ibid.).

---

3 In distinction to a functional typological approach as we find e.g. with Pevsner's history of building types (1979), Geipel suggests here grouping buildings according to formal criteria; that said, in a form that is to be found in continuous spatial layout.

4 Anthropologist Stephanie Bunn (2002) shows the variety of tent and other itinerant or temporary structures that have been used in the Arctic with the Inuit, with the First Nations in North America, the Bedouins in North Africa and the Nomadic tribes in Central Asia.

5 From the visibility of the crowd to a spectacle, to visibility for control in the sense of the ‘panoptic machine’ as defined by French philosopher Michel Foucault, who illustrates a state of permanent visibility in his analysis of Jeremy Bentham's Panopticon (Foucault 1995 [1977]).

With the creation of a continuous and deep floor plan challenges arise, concerning engineering but also for example in terms of fire protection, lighting, and ventilation. Monospace is not simply a formal task but depends (particularly above a certain size) on the performance of materials, processing methods and technologies. Albert Kahn, an industrial architect who extensively built for the Ford Motor Company, introduced reinforced concrete for better fire protection and double-shed roofs to allow for good and even illumination and ventilation (Ferry 1987). Frank Lloyd Wright likewise was able to develop the open plan office as early as 1906, with the Larkin Company Administration Building in Buffalo as heating and air-conditioning allowed for a large scale continuous well-tempered environment (Quinan 1987, 66 ff.). Thus, open plan and monospace structures are not simply empty shells but arise from a complex interaction between many specific conditions and needs. Contradictions easily emerge between the capacity to host large groups and the single person who for example wants to work or study in concentration. This draws attention to the relation between the shell and the furniture that occupies it. The carrel, which not only defines a territory but also mediates a specific activity within a large room, obtained great importance in work environments during the second half of 20th century. Office Landscape, a concept developed by the German-based Quickborner Team from late 1950s on uses furniture as means to create a non-linear, egalitarian working environment in the open office setting to break with the ideas of 'Fordism' and 'Taylorism' that had invaded the modern office layout, using the open plan as an economic and easily observable solution.<sup>6</sup> The relation of open building structures and easily changeable interior fittings and furniture is not only specific to fast-moving team-based working environments, but also points to a field of tension that is inherent in architecture in general and in monospace in particular: the question of stability versus flux—traditionally separated into stable architecture versus ephemeral social life.

Particularly with the open plan office building, the dichotomy of understanding architecture as tool, as 'a testing ground, not only for ideologies of power and productivity, but also for representation and identity' (Kuo 2013, 19), and architecture as a mere background for social life is a contentious issue. In the latter half of the 20th century 'the mantra of flexibility and profit' emerged 'leaving the architect's role to providing little more than a fancy gift wrap around a stack of generic floor plans' (Kuo 2013, 19f.). The monospace then reduces the architect to a designer of a fancy gift box, as a building's shell seems to add little to the mundane social hustle and bustle. Or is the opposite the case? Does the ultimate visibility, and the in-built flexibility as a tool of control, not elevate the architect to a designer of the social, disciplining people's behaviour? Both perspectives seem

---

6 For more on the concept of Office Landscape and their founders the two brothers, Wolfgang and Eberhard Schnelle, see Andreas Rumpfhuber *Architektur immaterieller Arbeit* (2013).

exaggerated, yet, these are the poles, in which the relationship between architecture and the social is traditionally conceptualised.<sup>7</sup> While architects tend to believe that their buildings have (at least) a structuring or organising impact and in more radical cases determining qualities, traditional sociology regards this as either presumptuous or paternal towards the users as sociologist Heike Delitz (2009b) points out. If considered at all in more detail, traditional sociology sees architecture as an attribute, mirror or embodiment of society (Delitz 2009a). Here we discover disciplinary boundaries, which as we will discuss later, current scholarship tries to challenge. Indeed, there are more complex and realist accounts of this relationship. However, let us stay for the time being with the monospace and this field of tension.

Although not confined to any specific culture, epoch or use, architectural historiography and theory particularly point to the modernist interest of opening up space (Curtis 1982; Giedion 1954 [1941]; Forty 2004). In the 20th century, there was a resurgence of efforts to get rid of the corridor, a tool of circulation, which had dominated western architecture since the 17th and 18th century.<sup>8</sup> Here architectural historiography presents the story of several avant-garde architects—Frank Lloyd Wright, Le Corbusier and Mies van der Rohe—often mentioned in combination with artworks ranging from Cubism, Futurism to Russian Constructivism. In its development throughout the early 20th century ‘space’ fell under topics such as ‘liberation’, ‘spatial continuity’ and ‘universality’, a physical as much as a philosophical project, particularly in the field of dwelling (Ngo and Zion 2002).<sup>9</sup> The list goes on: Buckminster Fuller, Cedric Price, Rem Koolhaas or Toyo Ito. Each figure who appears here will become known, amongst other things, for their concern with ‘open’ and ‘flowing’ spaces or spatial systems, which are supposed to distinguish themselves by a high level of ‘flexibility’, ‘transparency’, and structural ‘simplicity’—all terms which derive from a modernist vocabulary.<sup>10</sup> All terms

---

7 Architectural theorist Hilde Heynen (2013) provides an overview of the literature here, which she clusters around three categories: space as receptor (a neutral background for social activities), space as instrument (a tool to organise, structure or determine social activities) and space as stage (which integrates the former into a mutual relationship).

8 See Trüby (2016) on the cultural history of the corridor.

9 Following the three concepts of ‘liberation’, ‘spatial continuity’ and ‘universality’ the authors of *Open House. Unbound Space and Modern Dwelling* (2002) take ‘a new vision of architectural space’ at the beginning of the 20th Century and the ‘free plan’ as point of departure. They do so to examine how open houses as a physical attempt as much as a philosophical one endure throughout the 20th Century (Ngo and Zion 2002, 15).

10 See Forty (2004) on modernist vocabulary. For an introduction to modern architecture see e.g. Giedion (1954 [1941], Banham (1962) or Curtis (1982).

that can be attributed to the monospace and, as such, can indeed be discussed as a particularly modern phenomenon.

Adrian Forty elucidates that the modernist interest in ‘space’ was purpose driven as it drew attention to a new sort of architecture that permitted converse ‘with the socially superior discourses of physics and philosophy’ (Forty 2004, 265). As Forty goes on to explain, we should disclose the fact, however, that what they meant by ‘space’ was not a clear and fixed entity and surely not the same as that occurring in those adjacent discourses.

In this context, the work of Mies van der Rohe whose open plan buildings and approach have been studied and discussed extensively is exemplary (Neumeyer 1994; Blaser 2001; Hilpert 2001; Kim 2009; Fontenas 1998). ‘For Mies, “space” was without question the pure essence of architecture—but not of the architecture of all times, only that representative of the “modern”.’ (Forty 2004, 268) Several of Mies’ buildings, the design for the Cantor-Drive-In (1945–50, unbuilt), the Crown Hall in Chicago (1952–56) or the Neue Nationalgalerie in Berlin can be referred to as monospaces.<sup>11</sup> The typology of monospace is a specific case of open-plan architecture and a type that seems to be particularly controversial regarding its usefulness or value in terms of utility.

One must deduce that Mies van der Rohe’s desire to develop a strictly limited range of architectural ‘type-forms’ (such as the single volume pavilion) to accommodate all the diverse functions of the modern world, and his idea of completely flexible and adaptable internal space, were less practical than he liked to believe. Many activities do need particular room shapes and sizes, and particular lighting or acoustic conditions, which should be specifically designed into a building if it is to function well. It may be that spaces designed to suit *all* functions will not actually be particularly suitable for *any* function. (Vandenberg 1998, 22; original emphasis)

The concept of functionality, which is used here to evaluate the Neue Nationalgalerie, is closely associated with Modernism, but it is also as Forty explains, particularly a term of the criticism of Modernism (Forty 2004, 103–17, particularly 174–95). ‘A “function” describes the result of the action of one quantity upon another; relative to architecture, the question is what is acting upon what?’ (Ibid. 174) The functional relation of the Neue Nationalgalerie is more complex and the concept of functionality here seems too rigid to do justice to the life that is possible with that building. Whether it is a ‘decorative gift box’ for social life to emerge or

---

11 Here I always only address the upper part of the buildings under discussion and not the areas below ground that follow, for example in the Neue Nationalgalerie, a conventional ‘room-based’ plan layout.

plays a decisive role in shaping it—the truth must be somewhere in the middle, in the complex entanglements between buildings, space, time and people. Approaching this building through a causal relation of what is acting upon what seems insufficient hence ‘the modernist open plan is not functionalist’ (Hill 2003, 36).

In monospace architecture, our interactions and bodily relations with buildings are fundamentally different. Without walls creating rooms, there are no traditional corridors to follow, no doors with labels to knock on and open, no secrets behind these doors. The building plan does not tell much about the movement and action to be expected. Hence, monospaces urge us to rethink and discuss the relation of building and body, of architecture and the social and to evaluate our access to this relationship.<sup>12</sup>

Monospace is therefore a very interesting building type. Not only does it raise the question of what architecture does, how it allows, fosters or hinders certain activities (and here no quick answer can be provided). Furthermore ‘[d]irectly dealing with the problem of temporality, this theme [of the single large open space] delineates as well the limits of a strictly constructive idea of architecture.’ (Fontenas 1998, 9) This raises not only the question of the role of the architect but also the question of our understanding of the nature and field of architecture. The idea of shaping a static and a-temporal space seems to block access to this process-oriented architecture. That said, let us turn to previous accounts in the world of monospace buildings and learn from these attempts to grasp the relationship between architecture and the social before approaching the topic of space. Introducing monospace buildings, I left out many other aspects, architects, buildings and movements that could have been mentioned. However, this quick survey already shows that open plan architectures—and monospaces amongst them—form a large arbitrary group associated with diverse and theoretically charged concepts. How should we approach these buildings analytically?

Let us take another look at Mies van der Rohe’s Neue Nationalgalerie in Berlin (Fig. 1.3, 1.5), probably one of the most well known monospaces, to learn from existing research on this building. While the lower part of the building follows a traditional spatial layout, glass walls on all four sides surround the great upper hall. Used as a temporary exhibition hall, this monospace seems to challenge curators as much as it repeatedly encourages new installations and exhibitions. Two dissertations have recently been dedicated to this building. The first is within the discipline of architecture by Imke Woelk (2010) who approaches the Neue Nationalgalerie through its use with a focus on the material setting of the temporary exhibitions. The second study is (mainly) from a cultural studies perspective by Manja Leyk (2010) who discusses the building from a phenomenological tradition through the experiencing body and

---

12 On the relation between body and architecture and the diverse theoretical discussions of it with regard to architecture see also Hansmann and Geipel (2019).

the condition and effect of bodily movement. While the first dissertation focuses on the object the second concentrates on the subject.

The architect Imke Woelk argues that the architecture of the Neue Nationalgalerie emphasises the use of the building. Woelk refers to Umberto Eco's concept of 'openness' to point out the interdependency of building and use. The building of the Neue Nationalgalerie is to a certain extent unfinished until its usage starts, Woelk argues. Woelk attempts to discuss the performance of the building based on traditional architectural methodologies like the study and production of plans and diagrams as well as through a collection of photographs of almost all exhibitions up to the time in which she was writing. With an extensive vocabulary for key characteristics of the monospace, she builds up systematic categories to define spatial elements in the open plan. Regrettably, the project stops at the level of interior furnishing and does not consider the lived reality, something that is obviously challenged by Woelk's historical approach, but that could have shown how the monospace becomes 'finished'—or better yet, how it never possibly can.

While the spatial model and its bodily relation remains largely unthematized in the work of Imke Woelk, Manja Leyk on the contrary sets out from it. Leyk builds her analyses of the Neue Nationalgalerie on the concept of 'lived space' (*gelebter Raum*), a term she takes up from Graf von Dürckheim. Any human interaction with an existing built space produces further spaces. Leyk thus shifts the perspective from space as a container to a constant processual lived space, which she understands as a shared universal space experienced by different bodies. The specific focus here is on the relationship between human beings and the built environment using the case study of the Neue Nationalgalerie. Leyk observed and recorded on video visitor behaviour and supplemented and compared this with her own experiences. From her data, she depicts specific scenes and gives the reader an insight into the sensory impressions, such as vastness and narrowness, attraction and repulsion, through which the visitor of the building establishes a relationship to the architecture. The experiencing subject creates the access and point of analysis for an architecture that alternates between inner self and external observation. As Leyk notes, the observation reaches its limits in the interior of the Neue Nationalgalerie, in grasping the complexity of the forms of movement. Therefore, her case study focuses largely on the exterior.

The 'unfinished' character that Woelk emphasises hints that the objective world—neither in its numbers and measurements nor stylistic periods or historical context—is all that makes up architecture. Moreover, it is simply inadequate for understanding a monospace. If we look at a monospace, we have to deal with the relationship between architecture, space and body, in relation to its temporality. Leyk

approaches this relation by means of the phenomenological body.<sup>13</sup> This account seems to acknowledge temporality as it turns to the lived space. Studying the building from the standpoint of the subject, as Leyk does, adds a world of sensory impressions as well as an interpretative frame to the built setting. The relationship between human beings and the built environment here is established in the subject and while we connect to time and body we move around the object, albeit from a distance.<sup>14</sup> Turning to the world of sensory impressions seems to lack direct contact with the building and rather tell us something about human perspectives.

Nevertheless, to understand the mutual entanglements of people and architecture, it is important to overcome the common distinction of objective and subjective space. Somewhere at the interstices between these is the reality of architecture. There are scholars who attempt to overcome this distinction and who demand that we acknowledge the multiple dimensions involved in the life of a building (Latour and Yaneva 2008). In order to understand the question of multiple dimensions, we should first insure that of the three traditional dimensions of architecture have been taken into account. Let us take a look at the prevailing approach to space within the discipline of architecture, which forms the implicit or explicit basis of the work of architects and architectural historians and theorists.

## 2.2

### Which Space? Stability versus Flux

Space in architecture is a surprisingly young phenomenon, as the term 'space' did not exist within architectural discourse before 1890 (Forty 2004). Closely connected with the development of Modernism, its importance within architectural discourse grew rapidly:

- 
- 13 For an introduction to the divergent philosophical movement of phenomenology and a selection of texts, see Dünne and Günzel (2006, particularly 105–92). The challenge of capturing space and describing it led to a differentiated vocabulary within phenomenology. For example with Herrmann Schmitz, who built up a distinction between the sphere of emotion (Gefühlsraum) (Schmitz 2005a), felt body space (Leibraum) (Schmitz 2005b) and atmosphere (Schmitz 2014) to oppose, amongst other things, a rational and geometric view, and approaches from the social sciences.
- 14 Building on the work of Hermann Schmitz, the concept of new aesthetics as developed by Gernot Böhme tries to bridge the dichotomy between object and subject in perception by developing atmospheres created by things and people. Atmosphere here is theorised as 'thinglike, belonging to the thing in that things articulate their presence through qualities' and 'they are subjectlike, belong to subjects in that they are sensed in bodily presence by human beings [...]' (Böhme 1993, 122)

What distinguishes architecture from painting and sculpture is its spatial quality. In this, and only in this, no other artist can emulate the architect. Thus the history of architecture is primarily a history of man shaping space, and the historian must keep spatial problems always in the foreground. (Pevsner 1942, 7)

Space had become the 'essence' of architecture by the mid-20th century (Scott 1914; Giedion 1954 [1941]; Zevi 1957 [1948]). What space exactly was, however, remained disparate and varied depending on the interpretation. The term originated from a philosophical discourse in the 19th century and developed as an architectural category initially in Germany (Forty 2004). Without going into innumerable details here, I would like to highlight two fundamentally divergent approaches:

Architect and art historian Gottfried Semper develops in *Die vier Elemente der Baukunst* (1851, quoted here from the English edition 1989) a concept that concerns the primordial elements of architecture: to protect the fireplace three elements were grouped around it: 'the roof, the enclosure and the mound.' (Semper 1989, 102) The enclosure has a special significance in giving rise to the wall. Mats and carpets preceded, following Semper, the wall and dressed it also later as 'the visible boundaries of space' (ibid. 104). Architectural historian Adrian Forty sees Semper as an important figure who introduced space as a central category of Modernism and who influenced architects like Adolf Loos, H.P. Berlage or Peter Behrens in claiming that the task of architecture is to enclose space. Space here is 'a matter of enclosure' (Forty 2004, 258).

Art historian August Schmarsow in his essay *The Essence of Architectural Creation* in 1894 (Schmarsow 1994) presented another way of thinking about the very nature of architecture. He calls architecture 'creatress of space' (Raumgestalterin) (Schmarsow 1994, 288). Schmarsow locates the aesthetic value of architecture not in its materiality but in its 'sense of space' (Raumgefühl) and claims the physically experiencing body and its movement in space to be the source of architectural practice. Architecture here is determined by spatial experience that is located in the subject. The body becomes the origin of space. Schmarsow's ideas of the relation of body and space precede similar theories within phenomenology as we have already seen in the work of Leyk. This shifted the task of architecture from the creation of wall and boundary to the creation of void: 'constructed space is a kind of three-dimensional negative of the subject body's own sense of space' (Forty 2004, 261).

There are numerous other approaches to the topic of space in relation to architecture, e. g. the work of Hungarian artist László Moholy-Nagy (1967 [1928]) offers a concept of space as a flowing continuum that changes with human movement or



Rudolf Arnheim (1977) who conceives space as tension.<sup>15</sup> Some of these notions of space are more drawn to the object, some more drawn to the subject. Notwithstanding versatile individual approaches, in practice ‘[i]n the hands and minds of architects, space is generally emptied, and with this is made available as something that can be directly manipulated as some kind of stuff.’ (Till 2013, 118) By consequence space has ‘objectlike qualities’ and relates to stable, rigid, three-dimensional buildings (Till 2013, 119).

Talking about action and movement in connection to this kind of common architectural understanding we can think of movement as an action *in* space.<sup>16</sup> Most commonly, we have walls, floor, and ceiling creating a room, an interior space that is shaped by the architect and can be measured, and perceived. This kind of architectural understanding of space relies on an absolute understanding of space, as introduced above (Chapter 1).

The idea of the container, as a three-dimensional object, that contains space, builds on Euclid’s geometry. In 300 BCE, the Greek mathematician developed the notion of physical body defined by length, depth, and width (Mainzer 2010). The Roman architect and military engineer Marcus Vitruvius Pollio used these principles of geometry in his *De Architectura*. It is also in the first book of *De Architectura* that he postulates that a structure has to meet the three demands of *firmitas*, *utilitas*, and *venustas*: ‘durability’, ‘convenience’, and ‘beauty’ (Vitruvius Pollio 1914, 16–17). It seems that these ancient ideals still characterise common architectural practice and understanding. However, such ideals—and particularly convenience and beauty—indicate the relationship between buildings and people.

When turning to the question of space we seek to gain access to the complex entanglement of buildings and people. The traditional architectural understanding of space as it is concerned with the object engenders a focus on materiality, form and style while excluding the processes architecture is involved in. ‘[T]he problem with buildings is that they look desperately static. It seems almost impossible to grasp them as movement, as flight, as a series of transformations.’ (Latour and Yaneva 2008, 80) Yaneva and Latour place the blame partly on the production of perspectival space invented in the Renaissance. Drawing ‘a building in the perspective space [...] you begin to believe that when dealing with static objects, Euclidean space is a realist description.’ (Ibid. 81) Yet, where to locate all

---

15 An extensive compilation of central texts has been collected in *Architektur, Raum und Theory* (Denk, Schröder, and Schützeichel 2016).

16 Talking about movement in space, amongst the early philosophical approaches, *The Problem of Form in the Fine Arts* (1893) by Adolf Hildebrand definitely deserves mention. He suggests that space is ‘the means of talking about movement, in terms of the kinetic bodily experience of the subject’, as Adrian Forty puts it (2004, 262). For a general introduction to ‘motion’ in architecture see Jormakka (2002, 2005). Additionally, on the relation between the moving body and architectural layout see art theorist and perceptual psychologist Rudolph Arnheim (Arnheim 1977).

the different requirements, legal, economic, social, political, logistical, etc. which a project is constantly negotiating in its production and afterwards? This is what Yaneva and Latour ask. ‘You need only to think for one minute, before confessing that Euclidian space is the space in which buildings are *drawn* on paper but not the environment in which buildings are *built*—and even less the world in which they are *lived*.’ (Ibid. 82; original emphasis)

What possibilities does space offer when turning to the question of the relation of architecture to the social? With a view to the history of spatial theory, there are a great number of spatial concepts and approaches. However, the debate about the different concepts of space can be ordered along the fundamental distinction between absolutist-substantialist and relativist-relationalist concepts of space as sociologist Markus Schroer points out (Schroer 2006). This opposition can be found in the history of space in philosophy and natural science and serves implicitly or explicitly as a point of departure for today’s spatial considerations in the social sciences, as Schroer elucidates. Einstein’s explanation is helpful in this regard:

These two concepts of space may be contrasted as follows: (a) space as positional quality of the world of material objects; (b) space as container of all material objects. In case (a), space without a material object is inconceivable. In case (b), a material object can only be conceived as existing in space [...]. (Einstein 1954, xiv)

A relational space thus comes into being through the relation of places, things or people. Within social science the notion of a relational space is slightly different as there it is conceived as constituted by social operations. In the wake of globalisation and urbanisation this idea became widespread in the course of the *spatial turn* which introduced a more active understanding of space within the humanities and social science (Döring and Thielmann 2008). While the term *spatial turn* goes back to the book *Postmodern Geographies* (2011 [1989]) by human geographer Edward W. Soja, Soja’s reading was in fact drawn from French philosopher Michel Foucault and particularly French Marxist sociologist and philosopher Henri Lefebvre who are regarded as the actual founders of this turn to space (Döring 2010). At the outset of his first chapter, Soja uses two quotes from Foucault (Soja 2011, 10):

Did it start with Bergson, or before? Space was treated as the dead, the fixed, the undialectical, the immobile. Time, on the contrary, was richness, fecundity, life, dialectic. (Foucault 1980, 70)

In the course of the many small turns that the humanities and social sciences have passed through, the notion of space as backdrop, as a dead and fixed entity was challenged. Gradually an understanding came to prevail of space no longer

thought of as a solid, passive container but connected to the social and thus with the idea of process, of dynamic and motion. In this case, space is created out of a relative relation between bodies. As bodies are in motion space becomes ephemeral and constantly changing.

In the second quote, Foucault then suggests the ‘present epoch will perhaps be above all the epoch of space’ (1986, 22)—a commitment towards the era of space, which might sound old-fashioned to architects—after all, they had conquered space decades ago. As there is a certain consensus on space as the *essence* of architecture then the *spatial turn* as a recurring interest in space, at first glance, has not much to offer by way of architectural debate. On second glance, however, we can say that it has brought people and architecture closer to each other. They can share the moment of *making* space.

### 2.2.1 Space as Practice

While in absolute space a motion is not conceivable other than *in* space, with relational space we can consider movement as an action *with* space.<sup>17</sup> Space here is created in interaction, in the living architectural process, which involves objects, materials and people. In this instance, buildings do not reside *in* space cutting off a slice of absolute space to statically contain it they instead become part of a process. This is something essential to understand. Thus, space does not exist independently of bodies but is connected to operations or practices—it is never homogeneous. As such space has a bridging quality ‘between the realm of architectural scholarship and the theorization of space and social processes in other fields.’ (Crysler, Cairns, and Heynen 2012, 14)

French theorist Michel de Certeau took a step in this direction (Certeau 1984 [1980]). In Chapter VII of his book *Walking in the City* he turned particularly to the everyday practice of using the urban space and contrasts the structure and view of official planners who act in the state’s interest to discipline and control citizens, with the unpredictable transformations that arise from use.

First, if it is true that a spatial order organizes an ensemble of possibilities (e.g., by a place in which one can move) and interdictions (e.g., by a wall that prevents one from going further), then the walker actualizes some of these possibilities. In that way, he makes them exist as well as emerge. But he also moves them about and he invents others, since the crossing, drifting away, or improvisation of walking privilege, transform or abandon spatial elements. (Ibid. 98)

---

17 On mobility as a practice and its creation of space in geography see Cresswell and Merriman (2011).

Here, we can witness how the built environment and people become enmeshed. De Certeau's interest, however, is with the power of narrative and the story that takes place to make people connect to places by walking through them in a similar way as a speech act is performed.<sup>18</sup> While we gain an idea of the process involved with buildings, we do not get rid of a built environment as a framework and symbols that distance people and materials from each other. Rather than witnessing a doing in common, De Certeau's space relies on the space-reading subject who is entangled with signs and memories. Cultural theorist Ian Buchanan points out with regard to De Certeau's approach that 'the life of the city, the constellation of lives that make a city what it is, the actual experience of the city, in other words, is not contained in the concept of the city.' (Buchanan 2000, 110) This duality between lived reality and concept is one that we also face in relation to the monospace: As long as we stick to the *concept* of monospace we cannot grasp much of its living processes. Turning to the social we get a sense that architecture exists in a much broader network.

Lefebvre famously stated in *The Production of Space* that '(Social) space is a (social) product' (Lefebvre 1991 [1974], 26). In doing so, he laid the basis for the *spatial turn*. His concept builds on a complex of different elements: *spatial practice/perceived space*, *representations of space/conceived space*, and *representational space/lived space* (ibid. 38–39). Lefebvre's approach to space was driven by his interest and studies of everyday life and the phenomenon of urbanisation (Schmid 2005).<sup>19</sup> It is part of his project to critique 'abstract space'. That said, he does so in tying it to a critique of capitalism (Lefebvre 1991, 53). And thus 'Lefebvre's view of spatial practice, although it includes the aspect of action, is very much under the impression of capitalist structural constraints.' German Sociologist Martina Löw points out and identifies his notion of action as 'rather [a] behaviour under the condition of capitalism' (Löw 2008, 28). To understand space with Lefebvre as a 'produced' space brings architects and planners, buildings and the people dwelling in those buildings closer to each other. In addition, it expresses the temporality of space, its dynamic. Herein lies the chance to abandon a fixed architectural object in space. Yet, Lefebvre's space is always to be understood as part of his Marxist thinking and to be read in relation to his concept of society.

Amongst the contemporary approaches and theories on space with an explicit reference to architecture the work of German sociologist Martina Löw stands out. She presents in *Raumsoziologie* (2001; quoted here from the English edition 2016) a space-theoretical concept, understanding space also as a processual phenomenon. Space for Löw is constituted in interaction. She distinguished in this interaction two interwoven however analytically isolated processes, 'synthesis' and 'spacing':

---

18 For speech act as a performative utterance see Austin (1972).

19 In the late 1950s Lefebvre was in close contact with the Situationist International (Ross and Lefebvre 1997).

Space is constituted as a synthesis of social goods, other people, and places in imagination, through perception and memories, but also in spacing by means of the physical placement (building, surveying, deploying) of these goods and people at places in relation to other goods and people. (Löw 2008, 225)

While spacing is shared between nonhuman and human, Löw gives humans a superior position with regard to the aspect of synthesis, in which ‘social goods and people are integrated to yield space.’ (Ibid. 151) Löw’s first theoretical point of departure is Anthony Giddens theory of structure, which is based on a duality of structure (object) and action (subject); secondly, Pierre Bourdieu, who emphasises the body as intermediary between structure and action; and thirdly, on Reinhard Kreckel who stresses the linkage between matter and symbolism (ibid. 7). Löw succeeds in bridging the material and social world and integrates space into the context of action. Nevertheless she relies on the central figure of a space-constituting subject (ibid. 151).

As sociologist and cultural theorist Andreas Reckwitz emphasises (2003), turning to practices is about negotiating what ‘action’ is and what ‘actors’ are, and consequently about the understanding of the ‘social’. Thus, when turning to practice with respect to space the question of agency arises. Agency is traditionally conceptualised in social science through the dichotomy of structure and action: structure comprising the way in which society is organised (e.g., limiting free action) and action as the way individuals act independently. Discussion is about the relationship between these two—who determines or dominates what or whom. As emphasised earlier, the extent to which a human-centred focus in practice with the material world should actually be abandoned is contentious ground in the broad field of practice-based theory (Chapter 1). Sociologist Thomas Gieryn elaborates on the relation of structure and agency by comparing accounts of architecture by Anthony Giddens and Pierre Bourdieu, both sociologists (Gieryn 2002). While each would agree that buildings are an ‘element of structuration and reproduction’ (ibid. 37)—they shape while also being shaped—Gieryn attests that Giddens has a more actor-theoretical attitude (stressing human involvement) and Bourdieu a more structural emphasis. In this sense, the different approaches, even those that explicitly claim to avoid a deterministic attitude of cause and effect, often tend in one direction or the other.<sup>20</sup>

From the point of view of architecture, which has a long tradition and focuses on materiality, it seems important not to lose contact with this very material world buildings are made of. To take a path that refers to the perception of the

---

20 See also the literature overview by architectural theorist Hilde Heynen (2013), especially under her third category: ‘space as stage’.

built environment, emphasising levels of memory and imagination or deciphering architecture in its social reality of larger social systems, understanding it as embodiment or mirror of society, seems ultimately to pull architecture out of focus. Yet, focusing on the materiality, as discussed previously, does not help either in grasping the reality of monospace in its social entanglements. There must be a path somewhere in between.

ANT differs crucially from more traditional sociology in that it rejects a separate social *context*, such as society, through which architecture is to be explained (Latour 2005; Yaneva 2012); it takes a stance between subject and object. As research methodology it is rooted in the study of laboratories and thus pays close attention to the material, epistemic and social dimension of such object rich settings (Latour and Woolgar 1979). Developing an explicit interest in the involvement of objects in practice, ANT suggests an alternative way to the classic dualistic divide of subject and object; it offers to architecture the possibility ‘of seeing, hearing, sensing and then analysing the social life of things—and thus of caring about, rather than neglecting them’ (Mol 2010, 255). Turning to processes with ANT thus seems fruitful for understanding social space *with* architecture.

“Objective” time and “subjective” time are like taxes exacted from what peoples the world, they are not all that these multitudes do and see and mean and want. We are not forced to choose forever between losing either the feeling of time or the structural features of the world. Processes are no more in time than in space. Process is a third term [...]. (Latour 1997, 172)

Approaching process with ANT provides the possibility of thinking a non-reductive interrelation between objects and humans and to account for the complexity that emerges in reality. A complexity that is particularly evident in monospace buildings.

Architects in general and particularly in Modernism assume that they have an influence on how the human community interacts and we will come back to this later. They do so contrary to a broad art historical, cultural and social scientific point of view (Delitz 2010), as mentioned previously. That said, it still seems important to thematise architecture’s agency. With ANT we can acknowledge this agency without falling into a deterministic stance by re-locating it in the complex interconnections that architecture holds. In the following, we thus turn to the concept of spacing, as elaborated by Latour, and explore it along with the idea of agency as provided by ANT.

### 2.2.2 Spacing: A Networked Space

If we think of a building as a field of possibilities, allowing, hindering and fostering certain ‘events’,<sup>21</sup> then we can trace this by following the movements and interactions between objects and human bodies. Space, as a result, is actively created during these multiple interactions. Let us have a look at something, which takes us back to when I approached my case study, the Sainsbury Centre for Visual Arts, for the first time. It is a little ethnographically-inspired account recaptured from my notes and will give not only an insight into what spacing is about and how we can trace it but furthermore provides a first glimpse into how I work with my empirical data in the empirical chapters below (Chapter 4–6).

#### A first visit



**Fig. 2.1**

Date: 27.04.2016

Location: Sainsbury Centre for Visual Arts, Norwich

I am a first time visitor. I approach the building from the university campus and walk directly to the museum entrance.

21 The term ‘event’ refers back to Alfred N. Whitehead and is used in the context of ANT to acknowledge that both humans and nonhumans create experiences together (Yaneva 2017, 168).

The sliding doors open. I enter the transparent cylinder—air blows down on me. I have to stop for a second before the next sliding doors open. Then I am in. I stop right behind the doors. It is smaller than I thought. My shoes make a squeaking noise on the rubber floor.

Glass railings to the left and right guide me in the direction of the smooth white reception—I cannot fully see the person sitting behind it. I have to step closer to do so.

The receptionist welcomes me and explains that the Living Area contains the permanent exhibition. It is for free. At 11 am and 2 pm they offer guided tours a little display tells me. For the temporary exhibitions—‘Giacometti’ downstairs, and a photography exhibition on the second mezzanine—I will need to purchase a ticket.

I cannot survey the whole inner room. I decide to explore the living area first and take a tour the next day.

I leave the reception, follow its circular shape to the right and walk into the art gallery. I step onto the soft grey carpet that separates this area from the entrance area. I hesitate.

I look up at the ceiling—grey metal strips in layers—I follow them with my eyes.

Then I look down the path that is loosely defined by artworks in front of white walls. Then a little sculpture catches my attention. I walk around the display box and stop again in front of it, looking directly at it. A very small label with white text states: ‘Figure of a walking hippopotamus. Dynasty XII (c. 1880 BC), Egypt, Faience, 1973. UEA 306’.

I turn around, follow the panel in front of me until its end, look around the corner and walk on. Stooping to read a label, I now recognise that I am in front of Henry Moor’s ‘Mother and Child’. I change direction. Slowly I start meandering around, exploring the art collection of Lisa and Robert Sainsbury.

This walk is not a simple walk from A to B. Many different ingredients direct it: sliding doors, glass railings, artworks, labels, etc. My walk is a meandering, but it also speeds up and slows down, and unexpected events happen. Entering the building, the sliding doors set my pace. It seems like I am walking too fast for them, as they open with a little delay. Speeding up again, as the reception is prominently located in front of me, and the two glass railings to the left and the right do not give me much of an option to take a different path, I walk straight to the counter. Here I gain some basic information about where I am allowed to move and which areas are restricted. Considering that it is late in the afternoon and there is not much time left until they close, I decide to visit the Living Area, which is free of charge. The change of material, from the dark rubber floor to the soft carpet in the exhibition area, the freestanding display boxes and the white panels are all



active elements in my walk. This walk is spaced by all of the different ingredients that take part in it. We will explore the building, the exhibition and several of the elements mentioned here later in more detail. Let us focus for the time being on the relation of my walk to the objects, materials, signs, and oral information, etc., which are in a sense taking me for a walk.

One could argue, that this kind of walk is characteristic of sightseeing. It is a tour to make a study of the building. Concerned with exploration and open to experience, only in this kind of situation can we deliberately let ourselves be guided. Japanese architectural historian Mitsue Inoue describes this kind of experience as characteristic of what he calls 'movement space': 'In movement space, fragmentary spaces are connected like links in a chain or beads on a string' (Inoue 1985, 170), an experience of 'continual change, the unknown of what was and what will be' (ibid. 171). Inoue connected this kind of experience to 'winding corridors' and 'circling paths' (ibid.). Sharing the idea of continual change, I nevertheless argue that this kind of experience is neither bound to the activity of sightseeing nor to circling paths as such. It is a characteristic of making space, of 'spacing', which as a concept stresses the processual dimension of the world.

Thus, I do not enter space when entering the building. There is no space contained inside the box, space is what emerges in movement and to put it more generally space is what emerges out of the course of action. Thus, there is never only one space, but innumerable spatial processes. The activity of 'spacing', and not its final product, 'space' as such, is the focus that follows non-linear processes, which always evolve around different hybrid-human-nonhuman constellations. Crucial to this point is to pose the question of agency. Who takes part in spacing?

## 2.3

### Agency: Who Else Is Acting?

'When we act, who else is acting? How many agents are also present?' These are questions that Bruno Latour has posed (2005, 43). As he points out, '[a]ction is not done under the full control of consciousness; action should rather be felt as a node, a knot, and a conglomerate of many surprising sets of agencies that have to be slowly disentangled.' (Ibid. 44) Thus, when I enter the Sainsbury Centre it is not only I as a human that acts. By using the ANT approach we can acknowledge that there are multiple materials and objects, views and sounds that guide me, or better, I walk *with* these manifold actors.<sup>22</sup> Following the principle of 'methodological symmetry', ANT does not differentiate between experience and action—action is

22 For an introduction to the term actor, which is not subject to a fixed definition in ANT see Mol (2010, particularly 255–57). For an introduction of the term actor in the context of a general introduction into ANT and a useful collection of arti-

an attribute to experience (Belliger and Krieger 2006b, 35).<sup>23</sup> This distinction conventionally allows for the separation of subject and object. Following a tradition of the American pragmatists of the early 20th century ANT acknowledges the active role that materiality plays in experience. Here, experience is not tied to the subject in a phenomenological manner, but used ‘as an umbrella term to overcome the epistemological split between subject and object’ (Jay 2006, 12). Following ANT, actors do not need to have intentionality or a free will. Therefore they are humans and nonhumans, materials, objects, techniques, texts, rules, etc.

To understand Latour’s concept of spacing it is important to clarify how ‘agency’ emerges and is shared by humans, nonhumans and *hybrid* human/nonhumans alike then we can draw a line to other processual concepts of space along with this definition. Actors establish and modify relations with other actors, and in doing so they form a network. Agency is distributed in these networks. An actor never acts alone, but through other actors. Hence an actor can be understood as a knot of countless associations. While walking, I am guided by the material world that forms barriers and thresholds and others that simply re-direct my movement in an unobstructed way. I am drawn to the little hippo figure. I encircle the free-standing case, as it allows me to do so. Actors can be challenging and mal-functioning—the entrance door especially raises my attention—it is in particular the mal-functioning or dis-functioning that makes us aware enough to actually recognise the spatial and temporal engagement of a specific actor.<sup>24</sup> In the course of walking, I am not fully in control, and I am not fully aware of who else is acting. My movement is not wholly conscious. Hence, re-collecting my trajectory, I have to slowly disentangle with whom I have walked in order to render the set of other agencies visible. Following ANT, it is important to carefully map out who contributed to a course of action, and who and what made a difference in order to avoid ready-made causal explanations:

An invisible agency that makes no difference, produces no transformation, leaves no trace, and enters no account is *not* an agency. Period. Either it does something or it does not. If you mention an agency, you have to provide the account of its action, and to do so you need to make more

---

cles see Belliger and Krieger (2006a). For a list of ANT terms see Akrich and Latour (1992) and Yaneva (2017, 167–70).

- 23 Experience ‘can encompass what is being experienced as well as the subjective process of experiencing it’ as historian Martin Jay explains. In his book *Songs of Experience* he also provides insight into the contested ideas of experience according to different traditions and thinkers (Jay 2006, here 12).
- 24 We tend to take technical objects for granted, as black boxes, as Latour explains and it is only a crisis, their malfunctioning, that reminds us of the very existence of these technical objects (Latour 1994).

or less explicit which trials have produced which observable traces [...].  
(Latour 2005, 53; original emphasis)

Predictable or expected actors may arise, but also others that have so far gone unnoticed and, at best, are surprising. It is less about cause and effect relations than about a network that allows the actor in its ability to act in its relations. This allows for the circumvention of a deterministic understanding of the relation between architecture and the social. We do not need to understand networks in terms of power relations but can take them as trajectories, as a re-directing or opening up of new possibilities.<sup>25</sup>

This question of control, of who acts, can also be addressed by the theory of attachment as formulated by French sociologist Antoine Hennion (2010). Hennion explores the world of the amateur, a world that is equally one of love as well as lack, or non-professionalism, which forces us to shift focus from the 'autonomy' of the subject to 'the precise nature of that which *makes us be*', the 'faire-faire' as Bruno Latour calls it (1999a, 22 ff.). While we easily get stuck with the question of who is in control or who is the agent that causes the other to act, both Hennion and Latour offer a solution by switching focus to the quality of the boundary.<sup>26</sup> Agency, a capacity to act, emerges from within the boundary, from inside heterogeneous relations.

This leads to another point: networks are not necessarily stable. The network of my walk only lasts as long as the relating takes place. Here, space (in its fundamental processual understanding) emerges. Actors participate in multiple networks, their role may differ in each of them, and this makes it complex to grasp them. Nevertheless, it allows for understanding an actor in its complexity and multiplicity. Building on De Saussure's relational understanding of semiotics, Annemarie Mol explains that ANT applied 'this semiotic understanding of relatedness [...] to the rest of reality.' (Mol 2010, 257) She gives the following example:

Thus it is not simply the term, but the very phenomenon of "fish" that is taken to exist thanks to its relations. A fish depends on, is constituted by, the water it swims in, the plankton or little fish that it eats, the right temperature and pH, and so on. (Ibid.)

Following the actors is not about examining them in their essence or by their being but understanding their relatedness (we will touch on this in Chapter 4). Following their contribution to practices, which emerge in networks, gives us an

---

25 See Latour (1994) for an example of how people and guns form together a (new) programme of action which neither had independent of the other.

26 See also Gomart and Hennion (1999) on the work necessary to immerse oneself in the art and Albertsen and Diken (2004) on art and ANT.

insight into spacing. John Law speaks of ‘network space’ (2002). I use the term ‘spacing’ following Latour (1997), however, to shift away from the noun, space, in order to stress the processual character by using present continuous: i.e. spacing involves work.

When turning to spacing and the attempt to understand the making of space in the shared agencies of humans and nonhumans, ANT leaves behind the idea of a greater social context in which architecture happens. Likewise, ANT negates any determination of the social through architecture. Instead architecture is part of the making of the social (Yaneva 2009c). When the decision is made between a lift or a staircase, Yaneva provides an insight that shows how this does not mean to ‘choose between mobility and immobility, activity and laziness, exercised control and self-control’ but to ‘be led to share agency with them in a different way.’ (Ibid. 274) We will explore the different ways of sharing agency when turning to the world of the building in practice (Chapter 4–6).

Before turning to the components of inquiry, let me provide a brief note on the critique we have to anticipate. The project *Spatial Agency* under the lead of Tatjana Schneider and Jeremy Till, follows a quite similar approach like this study in shifting the attention away from architecture’s traditional focus on the object. That said, Schneider and Till take up a different position with regards to space (picking up Lefebvre) and agency. They point out that Giddens’s theory of agency (which they assume to be one of the most relevant) is incapable of acknowledging an indirect way of acting and thus cannot deal with the relation of architect–building–user, since Giddens’s (human) agent would interact directly (Schneider and Till 2009). However, buildings mediate the architect’s intentions. Continuing they indeed see a solution in turning to ANT’s concept of agency, yet, and this is a frequent critique that ANT encounters, they criticise a lack of intentionality. Schneider and Till consider it necessary to ‘assert the basic principle of human purpose in architectural agency’ (ibid. 99), also because their interest is to demand the social responsibility of the architect.

Using ANT to approach architecture may come at a cost: i.e. it may well be the case that I do not protect or treat architects well and account for all their effort (or failure of it). On the contrary, I may call all of this into question. Even if the human genius is marginalised, ANT offers something different for understanding the connectivity of architecture and the social and here the building as an actor comes to the fore.

ANT suggests, a symmetrical approach that takes humans as much as non-humans equally into account. Here we can witness them together in their ‘doing’, here we can understand how the specific qualities of a building emerge and what difference it makes. Thus, spacing is about the connectivity of architecture and the social and in doing so it contributes to re-thinking architecture’s relations.

Of course, we are used to dealing with the physical world, its forms and materials in architecture. And, of course, architects are aware of the complex worlds that buildings create. However, to explicitly turn to the complexity in use and to make the work that creates space visible, to acknowledge it, and thus to leave behind a 'container thinking' asks a lot from architects, since it shakes the grounds of the discipline (Chapter 1). My approach thus will be different from traditional architectural analysis yet starts from this common basis.

A monospace is to a certain extent unfinished until its usage starts, Woelk points out with respect to the Neue Nationalgalerie in Berlin (2010). Turning to the Sainsbury Centre for Visual Arts, let us start to get to know this 'unfinished' object and its many contexts in which it is commonly presented first. Based on my empirical material, we then follow different courses of action within and with the Sainsbury Centre. Where is the work that needs to be done to produce space? What are the many spatial practices and how can we see them? Spacing is a very active mode of spatial production, a world in flux. How and where can we witness spacing?

Thus, this book picks up the trail to investigate the complex interrelation of the social and architecture in the typology of monospace, and in particular in the Sainsbury Centre, to show the challenges, negotiations and possibilities that emerge at the intersection of architecture and social life, when questioning traditional norms.

## 2.4 Components of the Inquiry

My account is to make spacing visible and analyse the social life of the building. In the empirical investigation, I ask how the process of spacing takes place, how people and building and the many objects and materials encounter one another and act together. As we can follow the enactment of networks ANT provides tools to trace the work of producing space. These networks consist of actors of all types, materialities and sizes—human and nonhuman. ANT's method of inquiry as it is rooted in STS is based on ethnography. Previous ethnographies into the field of architectural practice have shown how we can trace the entanglement of humans and nonhumans (Houdart and Minato 2009; Yaneva 2009a, 2009b). Likewise, I draw on ANT to focus on the process of spacing. Yet we begin with the description of the static architectural object along with plans and diagrams, collecting the existing dominant perspectives on the building to then better understand how ANT can contribute to the comprehension of a building in action.

Concerned with the Sainsbury Centre for Visual Arts *in use*, there are three components to this inquiry: (a) ethnographic observation of the daily routines at

the Sainsbury Centre focusing on the bodies, artefacts and actions; (b) conduct interviews of three types, semi-structured strategic interview, walking interviews and sketching interviews; (c) compiled visual records, plan data and archival materials.

(a) Over the course of two years in 2016 and 2017, I embedded myself for several weeks equipped with ANT-inspired ethnographic tools in the Sainsbury Centre. I approached the building as an architectural researcher who worked for several years in an interdisciplinary research cluster in close relation to sociologists and ethnographers. The participatory observations focused on mundane routines and rhythms, object related actions, rearrangements of material settings, and aspects of durability. The following questions were addressed in this context: How does the layout of the building relate to courses of action? What relationships arise between the shell and internal processes? How is the building structured and which material or immaterial actors (e.g. visitor rules, environmental restrictions) are at work here? Which temporalities become visible? How are objects mobilised in daily processes and in museum knowledge transfer? Which elements do which work and how do they rely on the help of others? What problems arise and what are (surprising) solutions and substitute actions? How does the Sainsbury Centre relate to the wider network of university, local community and museums in the UK?

In the course of my observations I took tours with volunteer guides during the permanent exhibition, joined a Mini-studio (education programme for small children), explored the handling collection and unwrapped objects from Papua New Guinea, climbed onto the trusses of the deep roof and wandered through the different layers of the shell. I joined the team at the reception and followed the dismantling of an exhibition. Above all I was concerned with the mundane activities of exploring the exhibitions, visiting and sitting in the school area, eating lunch in the restaurant and learning about the different activities possible with the building, just as I have done with many other monospace buildings before and after. Sitting down, taking notes, making sketches, walking around were key to my inquiry during every visit. Such participatory observing was driven by my interest in people, the artefacts and their interaction. This includes documenting movements and different types of interaction in words, photography or graphics.

During these observations it is the monospace that allowed me to trace the spacing. In a monospace, what happens here is affecting what happens over there. The monospace allows for a high level of connectivity to different activities (for better or worse). In the case of my research, this is a huge advantage. I have joined people at their working places in some cases particularly for the purpose of observation and in many cases for the purpose of an interview. While conducting the interviews (many of which took place in the East End Café or in the Modern Life Restaurant) the monospace kept me in contact with many other activities. Thus,

while conducting an interview in the Café the monospace enabled me to follow a group of children entering the building from downstairs guided by a singer and the sound of a ukulele (I would approach the education team later and learn in detail about their various activities of taking objects, materials or instruments for sessions into the Living Area). Things that take place behind closed doors in other buildings, where I as a researcher have to ask for permission to be allowed to have access, or of which I would never have known, are revealed to me by the monospace. Being there, the monospace is connecting me to all these activities, putting me immediately into the situation to be able to ask questions about specific events or courses of action. However, this does not mean that there were no closed doors for me and that I was not shown limits, for example with regard to security work.

(b) Next to 30 semi-structures in-depth interviews (b.1) with employees of the Sainsbury Centre Institute, academics and PhD students from the department of Art History and World Art Studies and the Sainsbury Research Unit, the lightning designer and an artist who exhibited in the building recently, the study builds additionally on 32 sketching interviews (b.2) and 2 strategic walking interviews (b.3), which proved to be particularly useful to approach such a complex and materially rich world as a building in practice is. While all participants who have a long-term engagement with the Sainsbury Centre and gave specific answers referring to their role and position were able to choose whether they wished to be mentioned in a pseudonymous form or by name, all temporary visitors and students who took part in sketching interviews were directly pseudonymised. All interviews were recorded on audio. All in-depth interviews have been fully transcribed and all sketching and walking interviews have been partially transcribed by third person. During the first research visit my student assistant at that time, Maria Lisenko, supported me and mainly engaged in approaching people to take part in sketching interviews (see Chapter 4).

(b.1) After a first explorative visit, I approached the Sainsbury Centre Institute, with a research request. Open-minded and supportive of my request, a week of back-to-back interviews with the institution's staff from all departments was arranged. The semi-structured explorative interviews, which normally lasted between 30 minutes to 1 hour, addressed questions about scope and responsibility, typical tasks and description of a working week, relation of the building and objects to these tasks, team organisation, relation to the university and broader networks. While the first 12 interviews were set up for me, afterwards I started snowballing from these people I already knew to approach other members of the institute or the department of Art History and World Art Studies. Some of the interviewees I approached several times with follow-up interviews to clarify or approach new questions or to organise participatory observation sessions, such as for the dismantling of the Rana Begum exhibition in autumn 2017 (Chapter 6).

(b.2) Next to the in-depth interviews, I asked interviewees to sketch the Sainsbury Centre and to draw their movements while talking and explaining it. This approach is based on the research methodology of mental maps which is mainly used in geography and psychology (Gould and White 1974; Downs and Stea 1977; Sommer and Aitkens 1982). While the more substantial amount of mapping research is concerned with geographic and urban environments, Kevin Lynch (1960) was one of the first architects who addressed the question of perception and its mental representations in the context of architecture and urban planning. Choosing a methodology that is commonly applied to research mental spatial representations, spatial orientation and knowledge might be surprising. However, it is important to point out that in the interviews people describe the building based on their experiences. The sketches are not simply illustrations but an analytical tool, showing the engagements of the people and explaining some of the arguments made. This proved to be particularly successful when approaching visitors or people who are only temporarily at the Centre for a short interview. Without having the opportunity to follow visitors one-to-one over a long period of time, and to observe their interactions with the objects, here, trajectories and the participation of the material world in particular became visible during the interview. We explore the procedure and the enhancing capacity of sketching interviews at length in Chapter 5. While in-depth interviews were pre-arranged, people who only took part in a sketching interview were approached directly somewhere in the exhibition area, or café and asked if they would like to participate.

(b.3) Another specific form of interview I used is the walking interview. Here, I asked for a tour throughout the building without suggesting a specific path. Thus, the interview is conducted while walking and guided by the interviewee and, as I will argue, additionally by the building and the many objects (Chapter 4). This form of interview is helpful to approach buildings in detail, particularly from the ANT point of view. A walking interview is a methodology known in the field of ethnographic research and used both amongst social scientists and geographers valued for the rich data it produces in connection to the environment (J. Evans and Jones 2011; Anderson 2004). This method is also known as ‘walk and talk interview’ and closely related to ‘go-along’ interviews as coined by Kusenbach (2003), which rather follow interviewees in the sense of participatory observation. Like the mental map interview, it is a methodology that is thus far particularly valued for its ability to discover the human meaning and understanding of environments (Anderson 2004). Furthermore, Kusenbach argues for the phenomenological sensibility this form of interview brings to ethnography (2003). In contrast to previous human-centred approaches, I examine its suitability in the ANT context by highlighting the active participation of the ‘walking setting’ in the course of the interview. While these kinds of interview are often used in neighbourhood and environmental research particularly concerned with what is said at which place,



where the connection of movement, location and interview poses specific challenges,<sup>27</sup> I applied this approach at a manageable distance (the building) and speed (by foot). Two participants were chosen due to their specific in-depth knowledge of the building, the first, Calvin Winner, for his specific long-engagement with the exhibition areas and the second, Trevor Smith, for his in-depth technical knowledge about the building and more specifically the lighting. In Chapter 4, I draw extensively from the first walking interview and there I discuss the methodology in more depth and combine it with diagrammatic drawings. The second interview contributes particularly to Chapter 6, which is concerned with the lighting of the building and the building's active participation in that process.

(c) I compiled and reviewed the published literature and plan data on the building, visual records and archival materials, newspaper reports, quantitative sources about visitors and some published and unpublished scientific reports on the building. I reviewed archival materials on the building in the photographic collection of the UEA, the Robert Sainsbury Library, and the UEA Archive.

For the qualitative data analysis, I use the software MAXQDA and analysed the interview according to open keywords (e.g. issues about light, locations in the building) and later on increasingly according to key themes (e.g. 'working with...'). The visual data (e.g., plans, sections, photographs) I use as a basis for my own diagrammatic analyses.

While my study started from a distance, by reading about the building and studying the floor plans, I moved slowly closer. Beginning with the first interview sessions in autumn 2016, I learned from others about their engagements with the building and experienced the building myself. During my third stay in spring 2017, I began more explicitly to observe. Digesting the material in between the research sessions, in summer and autumn 2017, I finally focused on the Rana Begum exhibition and produced pieces of thick description. These go to the core of the research, into specific interactions between objects and humans during the visiting and during the dismantling of the exhibition (see Chapter 6).

With the next chapter we embark on a journey to the Sainsbury Centre. While we could understand my trajectory into this world as one zooming-in to a more proximate distance, I would rather consider it a study with growing intensity towards the processual character of the building. Thus, we slowly gain a better grasp and insight by refraining from understanding a building as a single passive object that contains space. Instead we learn to trace what architecture does in the entangled networks of multiple actors.

---

27 See Evans and Jones (2011) and their approach on spatial transcripts enhanced with GIS (Geographic information system).



### 3

## The Case: The Sainsbury Centre for Visual Arts

---

In the previous chapter we shed light on the group of monospace buildings and the traditional understanding of space in the field of architecture. Based on the thesis that a monospace develops its architectural quality in the joint action of building, objects, materials and people, we furthermore have examined the possibility to access the relation of architecture and the social with a processual understanding of space as provided by ANT. In the following, we turn to the case study and gain a first overview of the architectural body and existing literature.

The Sainsbury Centre for Visual Arts by Foster Associates in Norwich, UK opened its doors to the public in April 1978. The Centre has originally been conceived to house the collection of Sir Robert and Lady Lisa Sainsbury, which they had donated in 1973 to the University of East Anglia (UEA) in Norwich.<sup>1</sup> An endowment by their son Lord David Sainsbury made it possible to realise a new building on the university grounds, especially for this purpose. The building programme was then extended during the design process by further activities with the idea of creating a new academic and social hub on campus. Today, in addition to the permanent exhibition of the Robert and Lisa Sainsbury Collection, a restaurant and a café, a museum shop, temporary exhibitions and the university's art history department and the Sainsbury Research Unit share a single volume inside the building's envelope without separating walls in a conventional sense.<sup>2</sup>

- 
- 1 Robert James Sainsbury (1906–2000) was the grandson of John James and Mary Ann Sainsbury, the founders of the UK supermarket chain Sainsbury's, and ran the family business together with his brother Alan John Sainsbury between the late 1930s and 1960s.
  - 2 The Sainsbury Institute for Art (SIfA) is the subordinate venture that brings together the Sainsbury Centre for Visual Arts (the museum), the department of Art History and World Art Studies and Sainsbury Research Unit for the Arts of Oceania, Africa and the Americas (SRU), but also the Sainsbury Institute for the Study of Japanese Arts and Cultures (SISJAC) and the South Asian Decorative Arts and Crafts Collection Trust (SADACC Trust), the latter both located in the city centre of Norwich.

The building is widely known for its iconic appearance and radical design approach. Characteristic of the Sainsbury Centre is the creamy white double-layered skin, with open ends. Here the all-glass walls are drawn back prominently presenting the inner steel framework (Fig. 3.1–3.2). And while there is a decent body of literature on the Sainsbury Centre and it has been viewed in the light of many different contexts, the building as an actor in everyday life has not yet come under scrutiny.

The typical introduction to the Sainsbury Centre is concerned with the ‘box’ and its technicalities stating that it is a Late-Modern building and an example of British High Tech architecture, which the architect Norman Foster next to Nicolas Grimshaw or Michael Hopkins is known for (Pavitt and Thomas 2018a). The story of the building has been told many times and we will explore the literature in the course of this chapter. There is even a biography dedicated to the building following its development and exposing the close relationship between the donors, the architect and the university (Rybczynski 2011). There exists a rich reference system, as we will learn, that is commonly mobilised to put the building, or specific features of it, into bigger stylistic, historical or cultural contexts. Here different ‘perspectives’ on the building can be collected, which are tied to specific narrations that tend to either freeze frame the building or make us lose sight of it (Latour and Yaneva 2008).

Let us start, however, with the architectural object, the monospace, which due to it is open plan layout and the one all-encompassing shell became part of this study. I will introduce the Sainsbury Centre from a traditional architectural point of view first, look at its location, plans and sections, show the functional allocations and point to different structural elements and materials, to work out in detail what the architectural body consists of. Thus, for a start, let us deliberately bracket the mundane life of the Sainsbury Centre and focus on the building in its pure and present appearance and the existing literature. Of course, this will not help understanding the specific qualities and relations, the everyday sociality, or the internal latent spatial structures of the Sainsbury Centre, but it will shed light on the abstract architectonic body and help to reveal the tension between a formal typological and a pragmatic approach to this specific building. Against this background, we will be able to better grasp how ANT can help to access the reality of the building in practice and thus to understand how spacing is different from the traditional understanding of space as contained *in* monospace in the following chapter.

The typology of monospace can be considered as architectural withdrawal from the use of matter as means to create spatial separations. Yet the Sainsbury Centre is not empty and I will include materials and furniture into the building’s description. Here the classical disciplinary borders (to interior design) are already beginning to blur. As I am concerned with the monospace, this introduction will

focus on the upper part of the building and neglect, to a certain extent, its areas below ground that follow a traditional spatial layout.

### 3.1 Exploring the Building According to the Plans

Approaching the Sainsbury Centre from the exterior, the white longitudinal container with its rounded corners lies at the west end of the campus of the University of East Anglia, near the River Yare (Fig. 3.1–3.4). The campus was newly established in 1963 west of the city centre of Norwich and has a strong relation to the landscape. Situated on sloping terrain, the building is about 130m long with a width of 35m and height of 10m. Positioned on a southeast to northwest angle with full-height windows at each end, the building is orientated into the greenery. A pedestrian bridge punctures the façade diagonally and connects the Centre with the elevated walkways of the adjacent university buildings designed by architects Denys Lasdun and Partners.<sup>3</sup> The façade is clad with panels; both walls and roof are covered with the same five types of elements: glass, solid and gridded, and additional curved panels (glass and solid) shape the junction between wall and roof. While the northern façade remains closed, except for two entrance areas on ground level, two vertical glass strips organise the appearance of the southern façade. Here, the conservatories are located inside the building. The roof plane has also been designed as a fifth façade; five strips of glass serve as skylights. The building furthermore includes extensive areas below ground, visible outside at its east end with the curved glass wall of the ‘Crescent Wing’ added in 1991 (see Fig. 3.7 for steps of extension).

In the following we move into the building along with the plans and have a look at the building step by step. We will first explore the overall structure to then move closer to discuss its zoning and circulation, before going into details about the construction in connection to the modulation of its climatic environment.

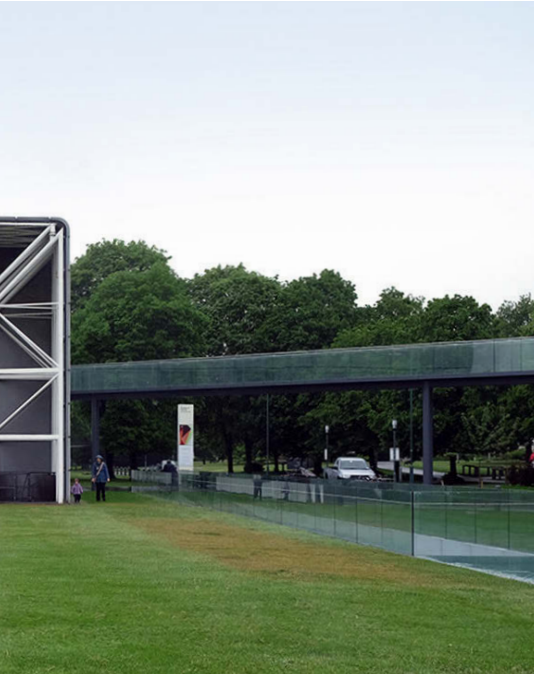
---

3 For a detailed introduction to the expressive concrete architecture by Sir Denys Lasdun and Partners for the UEA (1962–68) see *Architectural Design*, 5 (‘University of East Anglia, Norwich; Architects: D. Lasdun & Partners’ 1969). For details on the different possibilities of sites and a critique on choice of location see Peckham (1979, 6–7).



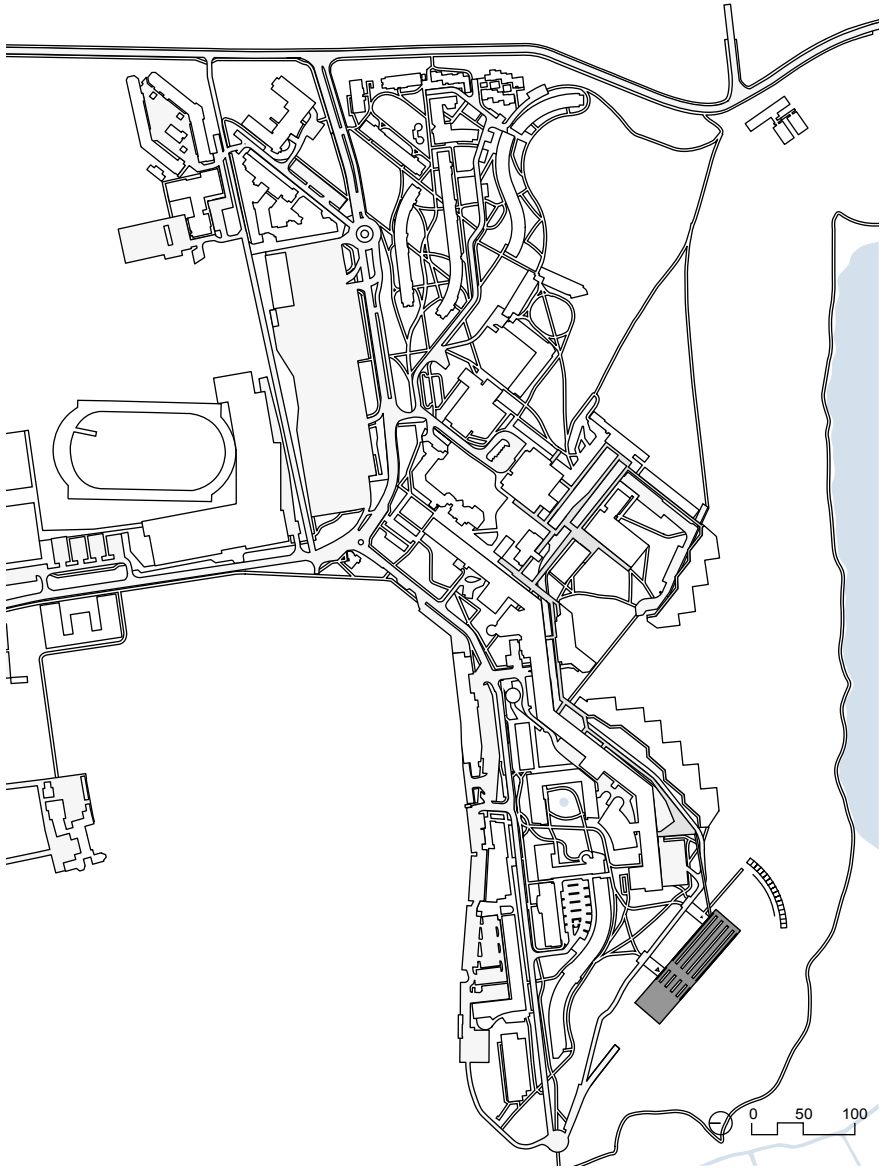
**Fig. 3.1:**  
View of the eastern end of the Sainsbury Centre (2017). The bridge connects the building with the walkways of the university campus.

**Fig. 3.2:**  
View of the building from the lake Yare with the curved façade of the Crescent Wing in the front (2016).



**Fig. 3.3:**

Southern façade (2016). The two glazed conservatories orient themselves here into the green of the landscape. The left glass band serves the School Area, behind the right is the East End Café.



**Fig. 3.4:**

Site plan. The building is located in the south west of the campus of the University of East Anglia, Norwich.



### 3.1.1 A Single Volume

The Sainsbury Centre is first of all a monospace because its all-encompassing shell creates a large continuous interior. What is special about this monospace is that it combines different functions. This is architecturally demanding, especially considering the uses of a public museum, restaurant, café, and shop in combination with teaching and research facilities, which all require their respective service areas. Instead of separating these functions into different buildings or detached building parts, they are largely integrated under the single shell. However, the continuous interior without dividing walls is only possible because two central building elements allow them to remain empty: the double-layered skin and the basement.

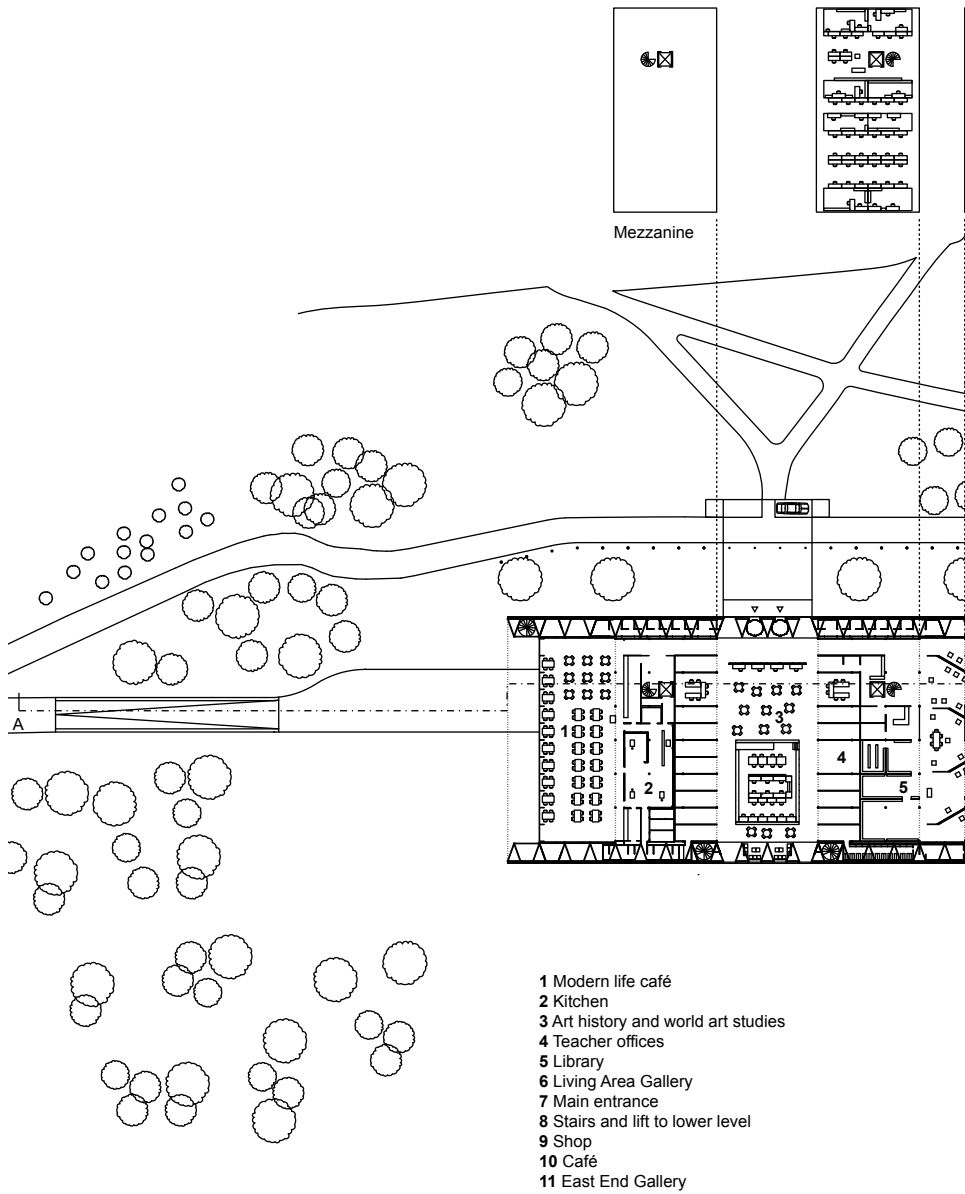
Firstly, there is the double layer of wall and roof. A system of triangular vertical trusses creates an open framework that provides a zone of a uniform depth of 2.4 meters between the inner skin of wall of perforated louvres and the outer façade of panels. This zone accommodates service rooms and secondary functions. Above ground, it houses runs of pipes and ducts, and electrical and mechanical systems that provide ventilation and lighting for the interior. Corresponding trussed beams span the width of 35 meters in the roof plane, and service catwalks in the depth of the structure give access to the gallery lighting up to a height of 7.5 meters, which can, as a result, be handled from above (Fig. 3.8, Fig. 3.23).

Secondly, there is the basement (Fig. 3.7). A spinal corridor runs beneath the full length of the building, housing storage and technical facilities. A loading bay allows for secure delivery and the unloading of exhibition materials in the basement. In the south of the building, the Crescent Wing, which was added between 1989 and 1991, emerges in the sloping terrain with a curved glass façade that looks out on the lake. This wing provides more office, workshop and laboratory space. Furthermore, it supplies a gallery/lecture space and a space for the reserve collection, each of which were functionally rededicated to gallery space during another refurbishment between 2004 and 2006.<sup>4</sup> These building parts are accessible from the outside through a long glass-roofed ramp and connected inside by various spiral staircases and lifts.

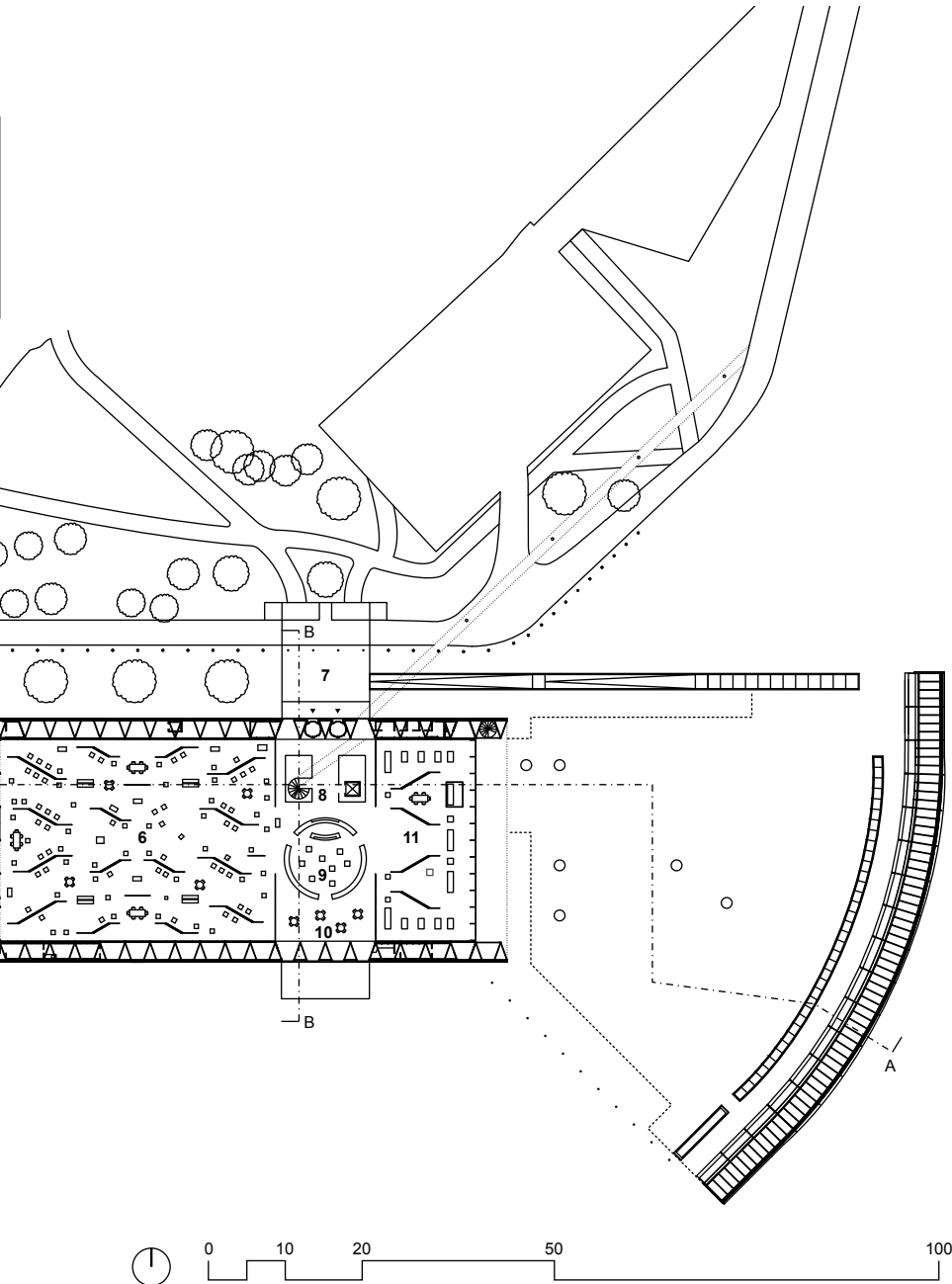
However, skin and basement are not the only devices that nourish the monospace. Simply by looking at the plan and section one can also readily see that there are mezzanine boxes positioned independently from the enclosing structure as well, low enough to allow for long vistas through the entire room (Fig. 3.5, 3.6). They house the offices for the university professors and lecturers, the library and seminar rooms and the kitchen for the restaurant; all necessary and subsequent elements of the building's programme are to great extent only separated by full-height glass walls.

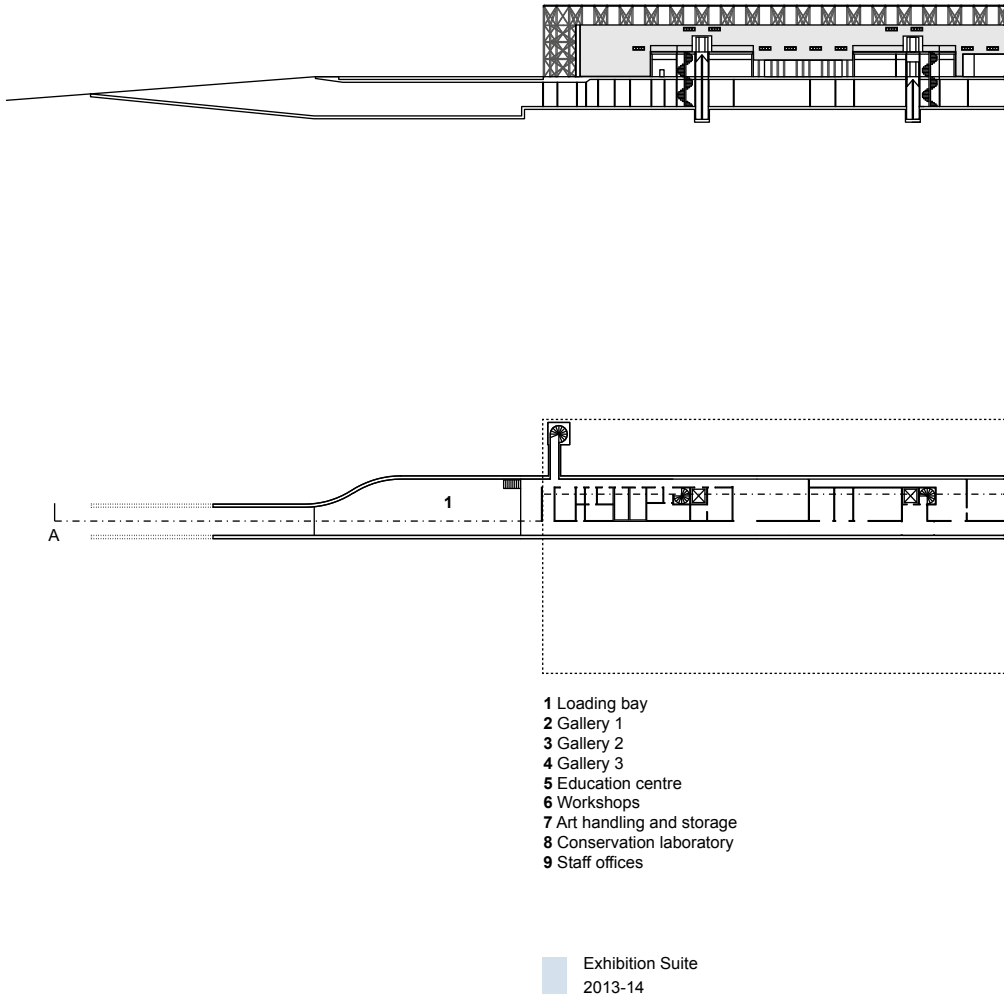
---

4 For a detailed description of the development of the design scheme see Powell (2010).



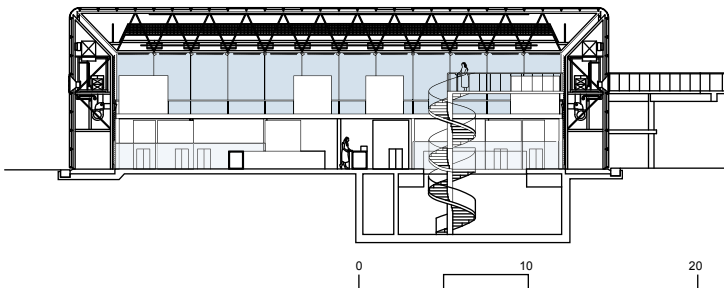
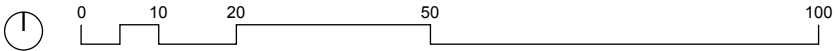
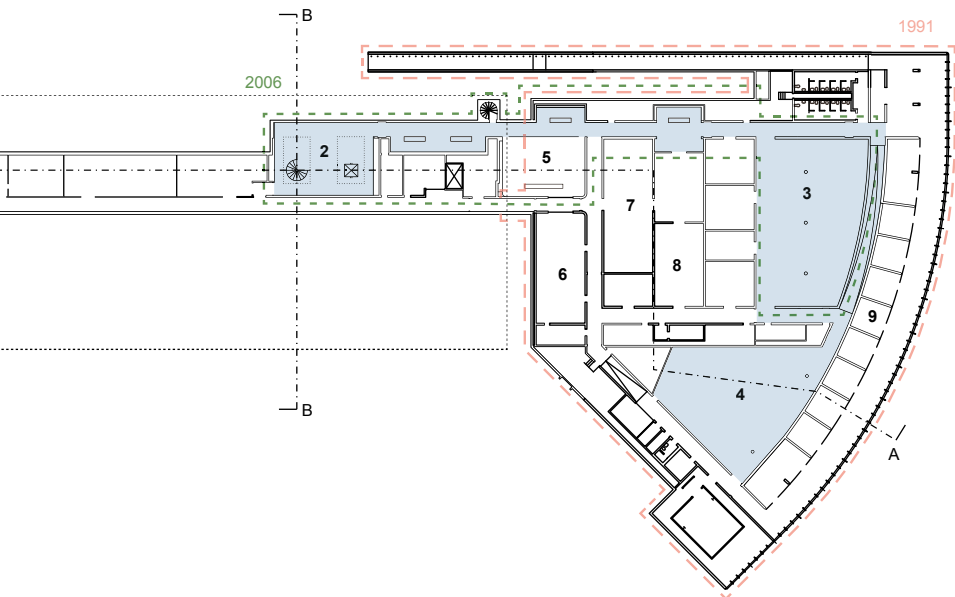
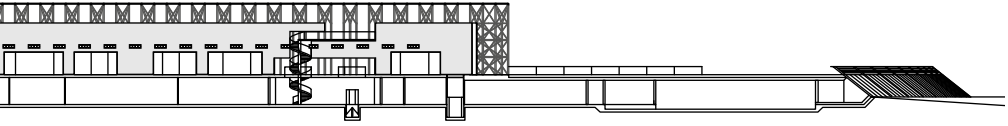
**Fig. 3.5:**  
Floor Plan. Groundfloor.



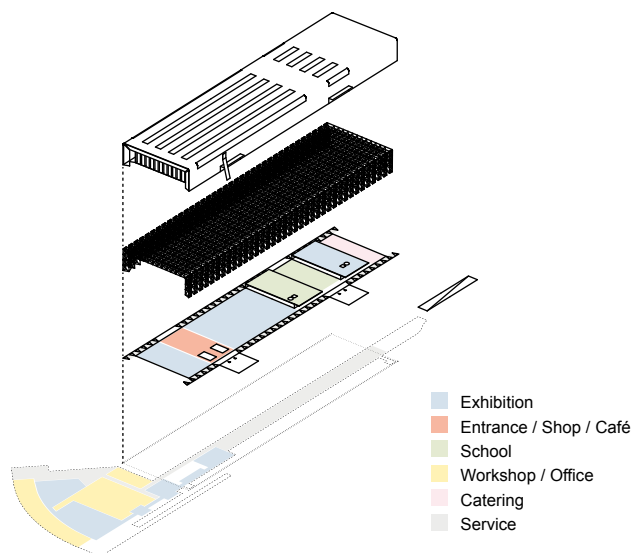


**Fig. 3.6, 3.7:**  
Section A–A.  
Floor Plan. Underground, with phases of extension.

**Fig. 3.8:**  
Section B–B.



### 3.1.2 Zoning and Circulation



**Fig. 3.9:**

Isometric exploded view with functional allocations.

The room in the ‘shed’, as the building is often called, is not simply empty. The different activities inside are located in neighbouring zones, like adjacent vertical bars; each of them articulated in a specific way, but connected by the all-encompassing building envelope (Fig. 3.9). Different devices help to structure the building (see Fig 3.5; use of numbers follows the plan).

Outside, there are two entrances that are the same in appearance—both with cantilevered canopies against rain and automatic glass doors to walk through (both added during the refurbishment in 2004–06). As there is a monospace behind, it might be surprising that there are two entrances (Fig. 3.11). It is only two triangular signposts, one rather large and the other small, both positioned at some distance to the entrances, which inform the visitor about the different functional allocations inside. Both face the campus, one entrance dedicated to serving the museum (7), the other to serving the Art History Department, the Sainsbury Research Unit and the restaurant.<sup>5</sup> These areas have different opening hours. While the museum entrance is closed during early morning or on Mondays, the university entrance remains open. This results in the necessity of being able to separate the different areas, public, semi-public, private, and to organise the building according to daily and weekly rhythms.

5 For more information on the specially established Sainsbury Research Unit for the Arts of Oceania, Africa and the Americas (SRU), see the interview with Robert and Lisa Sainsbury by Jonathan Benthall (1989).

The two mezzanine boxes, in particular, take over this task. Glass doors at their underpasses allow dividing the building into three main areas: The East End Gallery (11) and Living Area (6), with reception, shop (9) and café (10) in between; the Department of Art History (3) with lecturers' offices (4) under the mezzanines on either side of the central court; the public restaurant (1).

There are many devices that help to redirect flows of movement and to indicate allocations for different uses. Arrival via the main gallery entrance is into the area between the East End Gallery and Living Area. Here, the reception is part of the round shop of low white furniture with more cubes inside for presenting tenders (Fig. 3.12, 3.13). Behind the shop with a group of white tables and chairs, the East End Café is situated. The counter is hidden within the double-layered skin, which opens up to this area offering a view outside into the parkland. The floor covering a dark grey studded rubber floor sets the entrance hall apart from the exhibition areas fitted with carpets. In addition, partially shoulder-high glass railings support the separation of these zones and lead the flow of movement to the centre of the building.<sup>6</sup>

Let us slowly walk through the different areas along the plan. Firstly, we will move through the Living Area and the East End Gallery and then on to the first mezzanines, the school area, the second mezzanine and finally the restaurant.

The Living Area exhibits the collection of Robert and Lisa Sainsbury. Without walls to create a linear narration, it flouts convention—at least at the time of set up in 1978. The Sainsbury's collection is not the only collection of the Sainsbury Centre. That said, it forms the starting point of the collection and acts as an anchor for the institution's activity even today.<sup>7</sup> The art collection is not presented chronologically. On the contrary, the viewer enters a field of paintings and sculptures divided by screens grouped roughly into geographical regions, while the art of the late 19th and 20th century mixes in and spreads over the whole floor (Fig. 3.14). The patron envisioned presenting the art in an informal setting that allowed people to experience the object intertwined with their daily lives (Rybczynski 2011; Powell 2010). The Living Area has been rearranged several times, however without major changes during the last 40 years. Designer George Sexton (2003) depicts the following characteristic design factors, which still remain applicable: Freestanding objects allow viewing from all sides, two-dimensional works hang on free-standing screens, the walls of the Centre remain empty and comfortable seating and low tables (some with books on display) are spread throughout this area. Labels are only minimal, and the display uses daylight combined with artificial light. Special tables to study particularly

6 This is a relic from an earlier period. Initially, the glass railings ran over the entire width of the building and turnstiles controlled the galleries at their entrances.

7 The Sainsbury Centre holds next to the Robert and Lisa Sainsbury Collection, the Lisa Sainsbury Ceramics Collection and the Sainsbury Abstract Collection also the Anderson Collection of Art Nouveau and the University's Abstract and Constructivist Collection (Sainsbury Centre 2018b).

small objects were subsequently added, and some bookcases and seating elements have been removed to allow for the display of a growing number of artworks.

While the Living Area is reserved for the Robert and Lisa Sainsbury Collection, the East End Gallery, on the other side of the entrance area, shows objects of the reserve collection on a rotary basis. The exhibition furnishings are similar to that of the Living Area, but especially for this spot large glass showcases have been recently installed.

Another option to enter the building is via the pedestrian bridge. Inside, it leads to a spiral staircase, down to the entrance area and even further down to the basement, where the temporary special exhibitions in the Exhibition Suite are displayed (Fig. 3.15). The end of this bridge and the spiral staircase offer a prominent view over the whole interior (Fig. 3.16). At its back end, adjacent to the Living Area, is the library under the first mezzanine and beside it the gallery assistants counter. The first mezzanine has formerly been used for teaching and exhibitions. Today, it is divided by glass doors into postgraduate desk areas for the Department of Art History and the Sainsbury Research Unit for the Arts of Oceania, Africa and the Americas (SRU). Eight offices for academic staff as well as for members of the Sainsbury Institute of Art are also located in the same area. These offices situated in boxes with full-glass fronts are open at the ceiling and thus acoustically connected.

The school section includes a gathering and social area with groups of tables and chairs which are used by students as temporary workplaces or during lunch as well as for meetings (Fig. 3.17). To the left and right under the mezzanines, there are offices and seminar rooms detached from the spatial continuum by glass doors and walls with and without lowered metal blinds. An integral working area for undergraduate students is located on a rectangular lowered platform in the area between the mezzanines (Fig. 3.18). Surrounded by cabinets with a second elevated platform positioned in the middle of it, students working in the first lower area are visually disconnected while sitting. For the second group, however, the lower area serves as a moat, providing spatial distance, while still being visually connected to the surroundings in a sitting position. Behind the rectangular undergraduate working area, some lounge chairs and tables offer withdrawal next to the façade. The staircases, on both the left and the right, are hidden inside the double-layered skin, and serve the mezzanine levels. Through the last offices on this side of the building, there are further rooms, a tea kitchen for students and academic staff and a photo archive (a former photography laboratory) (Fig. 3.19, Fig. 3.20).

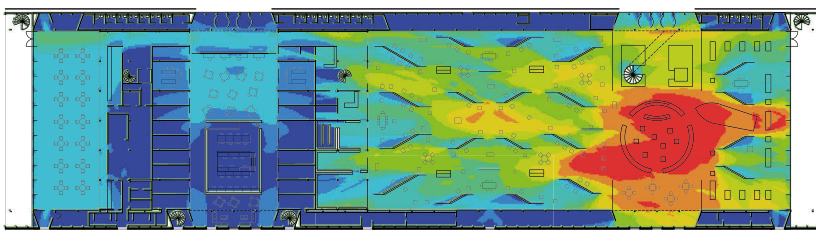
A white partition with closable sliding doors and signs separates this school area from the public flow that passes by from the Living Area to the restaurant, or an exhibition on the second mezzanine (Fig. 3.21). This also acts as a hindrance to the public; from the entrance, they are re-directed to the left and right.

The second mezzanine served various purposes throughout its career: senior common room and postgraduate desk area, office space—today, it provides an-



other floor for temporary exhibitions. Underneath, the kitchen for the restaurant is hidden, and while as far as possible all areas below the two mezzanines are covered with full-height glass walls, the kitchen remains invisible. Here, at the west end of the building, the full-height window offers a view from the restaurant, the Modern Life Café, to the lawn with a sculpture by Henry Moore surrounded by trees (Fig. 3.22). Hidden amongst the trees, the delivery ramp disperses in the underground avoiding the necessity for a serving façade at one side of the building.

After walking through all areas inside the building according to the plans and stressing the aspects that make them into separate domains, it is important to emphasise how each are also in some way related: the different materials, barriers and thresholds, create loose or strong boundaries between different zones, yet, the shell joins them. While various further analyses of the plan or even a 3D model (e.g. in terms of acoustics) are possible, I find the consideration of the understanding of the conditions of visibility particularly revealing. Analysing the floor plan with the help of Space Syntax with a Visibility Graph Analysis (VGA) at eye-level using Depthmap (Turner, 2010),<sup>8</sup> we see that the reception and shop are positioned in the area with the highest visibility inside the building (Fig. 3.10). Four zones can be distinguished in their visual integration. Firstly, areas with a very high degree of visibility (in red and orange) around the centre of the entrance area; secondly, areas with a high degree of visibility (in green and yellow) in the Living Area; thirdly, areas with a medium degree of visibility in the front area of the School Court and in the restaurant; and lastly, areas with a low degree of visibility in the rear part of the School Court and the adjacent offices (despite glass walls). VGA demonstrates that the interior can be divided into distinct zones with different degrees of visibility, which initially seem to correspond to the functional assignments.



**Fig. 3.10:**

Visibility Graph Analysis at eye-level.

8 A Visibility Graph Analysis (VGA) represents the number of points visible from any given standpoint in the building. To create a VGA at eye-level only furniture and display cases smaller than 1.5 meter have been included and regardless of size, glass elements have been considered transparent and excluded. The results are displayed in form of a heat map.



**Fig. 3.11:**  
Entrance area of the museum with information stele (2017).



**Fig. 3.12:**

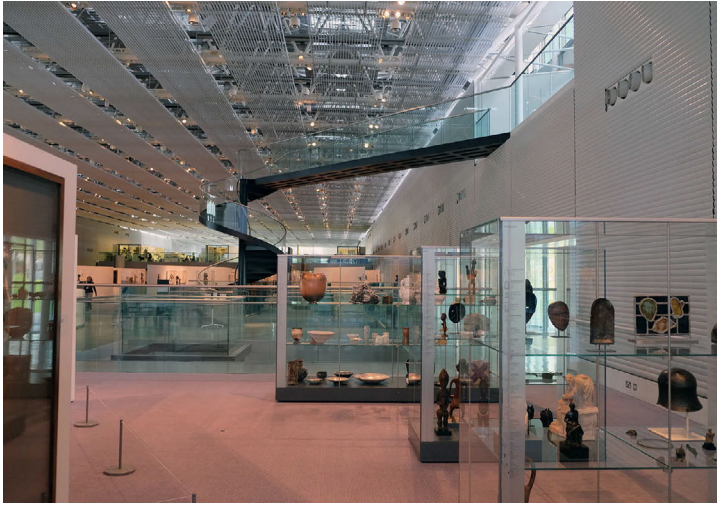
View from the pedestrian bridge (2016). Reception and shop with East End Gallery to the left, and Café in the back.

**Fig. 3.13:**

Reception desk (2017).



**Fig. 3.14:**  
Living Area (2017).



**Fig. 3.15:**

Inside the East End Gallery with large glass showcases in the foreground. Behind, the spiral staircase leading further down to the underground level (2016).



**Fig. 3.16:**

View from the pedestrian bridge towards the first mezzanine (2016). In the background the second mezzanine with theater curtain is vaguely visible.



**Fig. 3.17:**

Social area of the department of Art History and World Art Studies between the two mezzanines (2016). Students gather here to study and socialise.

**Fig. 3.18:**

View from the second mezzanine (2017). Students work next to the exhibition area.

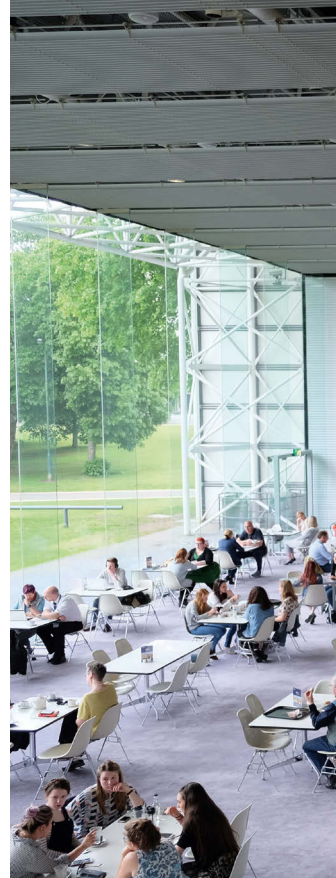


**Fig. 3.19:**

Photo archive inside the double-layered skin (2016).

**Fig. 3.20:**

Conservatory of the School Area (2016). Behind the doors staircases are hidden serving the mezzanine level.







**Fig. 3.22:**

Directly adjacent, the second mezzanine and the restaurant (2017).

**Fig. 3.21:**

Low separating wall between entrance and School Area redirecting visitors to the left (Living Area) or right (restaurant) when entering the building (2017).

### 3.1.3 Construction and Conditioning

The Sainsbury Centre belongs to the group of monospace buildings because of its decisive feature of one air volume created by the all-enclosing first climatic envelope. However, just like the zones that emerge with the rich material world and structure the open plan layout, the immaterial world of light, climate and acoustics are modulated and adjust the interior in a similar way. The internal environment is subject to a constant process of conditioning.

Closely developed with engineer Anthony Hunt, the envelope of the Sainsbury Centre is of a permeable and lightweight building structure. Except for the basement and ground slab made of reinforced in-situ concrete the building has been mostly prefabricated and assembled on site. It is a modular 'kit of parts' (Fig. 3.23) that allows for the replacement of elements (services and the cladding, for example). The triangular truss structure of welded hollow steel tubes aligns in the base of each triangle with the external façade while the third column, the vertex of the triangle (the apex), carries the inner walls. A continuous net of neoprene gaskets seals the external cladding. Six bolts from inside the building fix each panel. The original solid façade panels had been of silver-grey anodised aluminium with a ribbed surface, a sandwich construction, which contained an insulating layer of phenolic foam. After having had problems with corrosive action in some panels and leaks for some time, the whole building was stripped and re-cladded with new and completely flat cream-white panels of honeycomb aluminium with rock wool insulation and a PVF2 finish (in spring 1988). This process of re-cladding was also used to improve the ultraviolet filtering of the transparent glazing panels and the drainage system.

This construction method generates materials that have very meagre capacities to buffer humidity and temperature. Numerous thermal bridges and areas with single glazing make for a poor rating in the Energy Performance Operational Rating visibly posted in the building today. It comes as a surprise that the building has no air conditioning. Stressing that also previously the collection had been kept under normal domestic conditions, Fosters Associates' approach is a modification of the surrounding external damp British climate, rather than a hermetically sealed climatic chamber (Powell 2010). In contrast to the new underground areas, the storages and the workshops, which are indeed equipped with air conditioning, a simple air heating and cooling system handles the temperature in the shed centrally controlled by the UEA building management system. The air handling units (AHUs) are located in the double-layered skin and work by introducing fresh air into the interior, which they draw in through the grilled panels in the external façade, and blow through four nozzle diffusers prominently placed in the aluminium louvred interior walls.<sup>9</sup> It is a supply-only system, louvres in the upper part of

---

<sup>9</sup> This system does also provide modes of recirculation or partial recirculation, which allows for the recovery of heat during winter months; however it does not

the façade can be opened manually during hot summer days to support air circulation; the height of the room helps in this respect as well.

The ventilation has another effect: the hum acts as a white noise, which minimises the noise interference caused by neighbouring activities. Furthermore, the grey aluminium louvres along the walls conceal acoustic material (wood wool slabs) that lines the solid wall areas and just like people and furnishing the wide areas of carpet has an additional sound-absorbing effect.

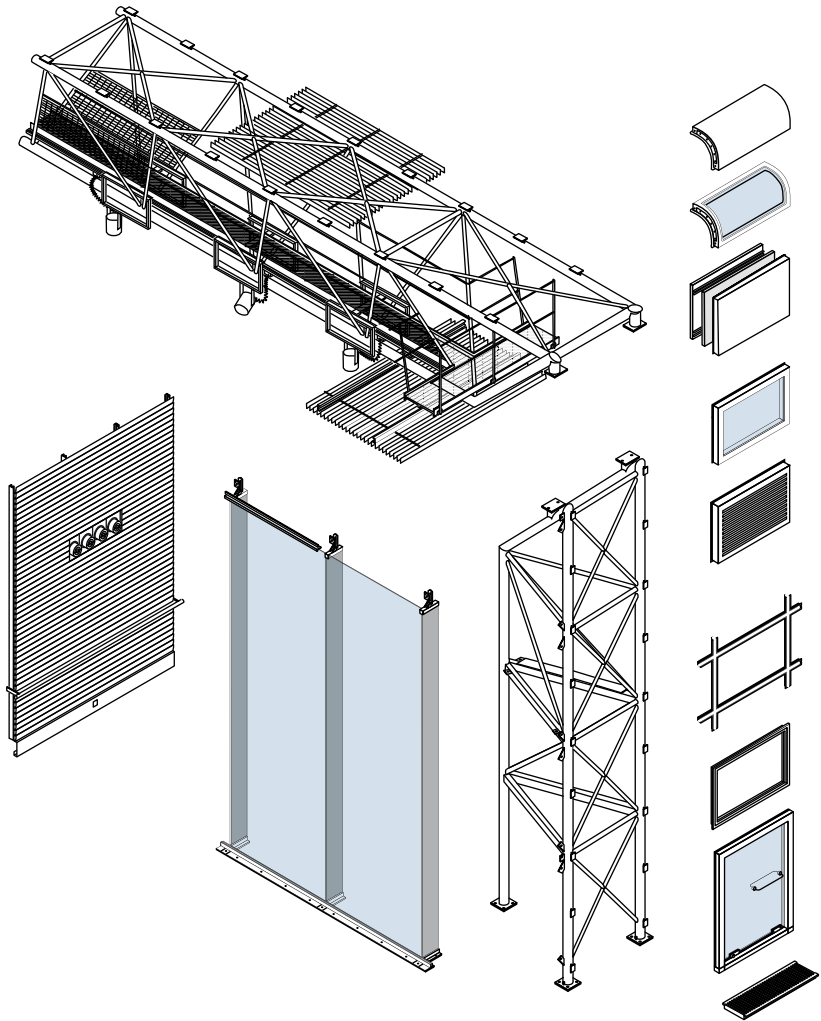
The building is open and permeable to temperature and humidity as it is to light. In the roof, the dissolved load-bearing structure allows daylight to pass through. Double layers of aluminium louvres, the upper one of the two motorised, permit the regulation of how 'natural' light penetrates and enters through the glazed parts of the roof.<sup>10</sup> In addition to the two full-glass façades at both ends of the building and the two conservatories facing south, these strips of roof-lights generate a lot of 'natural' light inside the building. However, it is only in the early pictures, that the louvres are open and the play of sun and shade exploited to its full extent. Conservation concerns have led to the fact that the Living Area today is illuminated mainly with artificial light (see Chapter 6). Georg Sexton together with Roy Fleetwood from Foster Associates designed a flexible lighting system, which can be handled from the rear via the catwalks. The monospace allows the light to travel, however the interplay of 'natural' and artificial light modulates zones of different lighting conditions and different degrees of connection to the outside world.

A multitude of devices support the monospace, and its huge inner air volume is not simply empty. The building generates or filters light, tempers and distributes air, reflects and absorbs sound, keeps rain outside while it allows humidity to travel. This brief technical overview provides an idea of how the interior world of the building is actively modulated; it is not simply empty and homogeneous. Diagrammatic analyses enhance in this sense the readability of the plan and allow assuming aspects like pathways, visibility, and functional engagement, when taking furniture and materials into consideration. There are indications of a complex world that suggests a close interplay of shell, materials and objects. Physical and non-physical devices, like the mezzanine boxes, glass railings, the different furnitures and materials, light, sound and climate modulate the inner world and build up distinctions between here and there, while other elements like the carpet or the aluminium louvres connect and emphasise unity. The shed is holding these different zones together. However, this is a lifeless material world if we do not consider its social entanglement. We do not know if this building indeed is flexible and adaptable, if it is changing. We do not know about its rhythms and constraints and as such about its possibilities.

---

provide a humidification control and thus poses a challenge for meeting museum conservation standards (Ledinskaya 2015; Camuffo 2001).

10 As I will argue later, light is never 'natural' but made with a lot of devices (Chapter 6).



**Fig. 3.23:**  
'Kit of parts'.

## 3.2 Perspectives on the Building as ...

Approaching the building by technical and functional description by way of its plans, by visual examination and initially diagrammatic analysis we can gain a clear understanding for the abstract architectonic body of the Sainsbury Centre. That said, so long as we do not turn to its lived reality we only face an abstract and static object. However, reviewing the literature on the building we find little indication for this mundane world. In the following we turn to the body of literature about the building more closely. What has been said and written about the Sainsbury Centre? What can we learn from ‘outside’? With the term outside I refer to the many contexts, social and cultural that made this building possible, the biography of the architect, as well as the philosophical, historical and stylistic frameworks commonly mobilised to analyse and contextualise this building. Thus, we will enter a discourse that is predominantly concerned with the question, ‘*Why* is the Sainsbury Centre like it is?’. That is an interesting question, especially given the emergence of this project in the transition phase of the 1960s and 1970s. Instead of retelling these stories one more time, I will give a brief overview and point out the specific and dominant narratives: Firstly, the theme of flexibility, material lightness, and their close connection to questions of style; secondly, the star-architect and the reference system that is mobilised through and with it; thirdly, the founding myth of the Sainsbury Centre.

### 3.2.1 ... a High-tech and Late Modern Museum Building

Turning to architectural history and theory, there are many categories, concepts and interpretations that we can take up to discuss the Sainsbury Centre.

It is a contradictory building—a hybrid exhibition, gallery, and museum building; its form, a light-weight flexible enclosure, supported as a monumental and spectacular structure; a cultural building housing “art” yet constructed in a tradition of the 19th century engineering “technique”. (Peckham 1979, 25)

Each aspect here does indeed come with its own particular discourse and framework and there are different ways of contextualising this building.<sup>11</sup> As already

---

<sup>11</sup> The most recent contextualisation of the building took place with the exhibition *Superstructures: The New Architecture 1960–1990* (24 March – 2 September 2018) at the Sainsbury Centre on the occasion of its 40th anniversary. The accompanying catalogue presents the building in the context of High Tech architecture, in the tradition of engineering and industrial material experimentation and the utopias and megastructures of the 1960s and 70s.

discussed (Chapter 2), the topic of open space is an especial concern of Modernism. Following English architecture critic Reyner Banham, we can understand the Sainsbury Centre as the realisation of a modern dream, ‘the dream of the infinitely flexible and perfectly conditioned art gallery’ (Banham 2000, 85). Generally speaking Foster is considered a modernist architect. When architect and architectural theorist Charles Jencks announced modern architecture was dead and postmodernism as its successor (Jencks 1991 [1977]), Jencks invented a further category, the ‘late modern’ for architects like Foster. At a time when the ideal of modernity was already in question, buildings like the Sainsbury Centre but also the Centre Georges Pompidou (1977) by Richard Rogers and Renzo Piano explored similar technical and architectural themes. While these were rooted in Modernism, they now were able to push architectural boundaries towards industrial production. The connection between Foster and Rogers is not accidental but stems from time studying together at Yale and subsequently from the joined office Team 4.<sup>12</sup> With the Reliance Controls Factory (1966), an elegant box of metal cladding with wall-high glazings and exposed structural stiffening, they had explored architectural aspects such as fluid open space, flexibility and prefabricated components together before their partnership broke up in 1967.

Thus, when approaching the Sainsbury Centre the literature suggests looking at the project genealogy of Team 4 and then Foster Associates.

Foster Associates’ development of the modular pavilion from the industrial box is fascinating to behold. Throughout the ’70s, boxes, large and small, were their speciality. After Reliance Controls there followed Computer Technology, Hemel Hempstead, IBM Cosham, the Modern Art Glass warehouse at Thamesmead and the SAPA aluminium extrusion plant at Tibshelf outside Derby—about as minimal and enigmatic a box as one could wish to see. None of these seems very remarkable now. They are largely of academic interest as precursors to the Sainsbury Centre—the last word in sleek sheds and the end of the line for that particular built form. (Best 1982, 41)

---

12 At Yale, one of Foster’s classmates had been Richard Rogers with whom he would become friends. Rogers joined Yale coming from *Architectural Association* (AA) in London. This was at a time when Peter Cook and David Greene started *Archigram*, a famous student magazine at AA that featured high tech and lightweight utopian projects. In 1963, one year after graduation and a short period of work in the USA, Foster returned to England and joined Rogers in setting up the architectural studio *Team 4* together with the two wealthy sisters Georgie Wolton (who left after a few months) and Wendy Cheeseman. With some starting help from the family of the soon joining Su Brumwell (Rogers’ first wife), they managed to realise several projects and entered some competitions.

It can indeed be revealing to have a look into the early projects, as it becomes clear that the Sainsbury Centre is not the result of an ingenious idea. Many earlier projects allowed these thoughts to be developed and tested. Thus, it is a development *with* many projects. However, we need to be aware that such a discussion bears the risk of presenting the project genealogy as a linear development. This could underexpose the detours, discontinuities and innumerable ramifications. Nevertheless, there is also the chance here to show the many repetitions, imitations and small shifts that determine the emergence of something new. This is a path that follows the details of the architectural practice (Yaneva 2009a; Houdart and Minato 2009). As early as 1970 the *Architectural Design* magazine featured the work of Foster Associates with a special issue (Foster Associates 1970). Here ‘the reduction of the building design into a series of zones’, the ‘integration of structure, service and external skin, to the point of single elements performing dual functions’ and the aim of ‘providing a maximum degree of flexibility’, was already developed programmatically for the office at this point in time (ibid. 237).

The aspect of material treatment goes along with a further category of British High Tech. And here Foster Associates is named in the line with James Sterling and James Gowan, and Richard Rogers Partnership as a pioneer (Sudjic 1986). The Sainsbury Centre is considered ‘High Tech, in the sense of the rejection of conventional building materials and constructional practice’ (Dorner and Muthesius 2001, 38). Stemming from a 1960s approach, most of the components are prefabricated and the centre was rather assembled than built. Except for the in situ concrete foundations and the basement, which famously make up the bulk of the building’s weight (Pavitt and Thomas 2018b, 18), the building is produced out of prefabricated, dry machine-made components. As such the elements of the façade are interchangeable, glass and solid elements could be relocated. Prior to the installation of the rain canopies above them, even the two main entrances would have been easy to relocate—this never happened, however. The former anodised aluminium panels had to be replaced a few years after opening due to leakage. The purpose-designed panels are part of Foster Associates’ approach towards new materials. An interest which is said to be driven on the one hand by the ability to free buildings from their masses and on the other hand to reduce energy consumption (Sudjic 1986). Foster’s biographer Deyan Sudjic stresses that ‘[p]erformance is one of Foster’s most consistent goals’ (ibid, 39) and as such the question of being modern would be ‘an attitudinal stance, rather than a commitment to a particular style.’ (Ibid. 46)

Looking only at the built materiality the Sainsbury Centre offers flexibility and adaptability to meet future changes. It looks as if it can extend itself at both ends, which stresses the idea of the ‘building as an unfinished process’ (ibid. 59). Flexibility, as associated with the idea of opening architecture to the unknown by making it easily changeable or adjustable, was a term that came about particular-

ly in the 1950s (Forty 2004, particularly 142–48). And while flexibility underlies a non-deterministic touch, ‘that the architect should conceive buildings not as monuments but as receptacles for the flow of life which they have to serve’ (Gropius 1954, 178), this was controversial from early on and criticised in connection to functionalism. As Forty stresses, ‘The incorporation of “flexibility” into the design allowed architects the illusion of projecting their control over the building into the future, beyond the period of their actual responsibility for it.’ (Forty 2004, 143) Flexibility in relation to the Sainsbury Centre consists of two different aspects. On the one hand, there is the large interior, which potentially allows various installations and, on the other hand, there is a technical flexibility concerning the interchangeable façade and technical equipment. The latter of which creates a certain proximity to Cedric Price’s Fun Palace.<sup>13</sup>

Approaching the question of style not only do other buildings and practicing architects, the comparison of categories and terms, materials and construction methods move into focus but also the architectural company Foster Associates and the person Norman Foster.

### 3.2.2 ... the First Public Commission of a Star Architect

When commissioned with the new museum on the Campus of UEA in 1974 the young London-based architectural firm Foster Associates had been involved with several low budget and industrial buildings. Considered in terms of years of practice and also building experience, Foster Associates was relatively young—neither had built a museum nor any sort of campus building. The major commission of the Willis Faber & Dumas Headquarters in Ipswich (1975),<sup>14</sup> that would become award winning and together with the Sainsbury Centre establish Foster as a leading architect amongst his generation, however, was not yet completed. It is unclear how exactly Foster Associates got into the smaller selection of architects considered, but the Sainsburys took an interest in Foster after a visit to London’s Millwall Docks seeing the Operations-Amenity Centre (1969) and the Passenger Terminal (1971) that Foster Associates had realised for Fred Olsen Ltd. The former was a two-story building with a steel and glass façade built into the fire separating strip between two cargo halls. Amenities (canteen, showers and games room) were provided to dock workers and managers alike on the lower level and an open plan administrative office on the first floor (again shared facilities and the functional mixture was exceptional).<sup>15</sup>

13 Compare Hill (2003) on flexibility by technical means with regard to Price’s work.

14 See Bramante (1999) for a detailed introduction to the Willis Faber & Dumas Headquarters.

15 For a detailed introduction to the Operational-Amenity Buildings see Architectural Design 5/1970 (Foster Associates 1970, 240–51).



Norman Foster, is regarded today as one of the world's most prominent and influential figures in architecture (Sudjic 2010) and 'as a leading figure in British intellectual culture generally' (McNeill 2005, 502). With the Sainsbury Centre commission, it has been emphasised that 'at the age of 42, *he* had joined the small rank of world architects' (Jodidio 1997, 14; emphasis added).<sup>16</sup> Subsequently in 1979 the office was commissioned to build the new headquarters for the Hong Kong and Shanghai Banking Corporation in Hong Kong China (completed in 1986)—one of Foster's most prestigious commissions, followed by the Reichstag Building in Berlin, Germany (completed in 1999).

It is four decades ago that the Sainsbury Centre opened its doors. Today Foster + Partners is an international company involved in architectural and design projects ranging from urban master plans and airports to private houses and furniture design. The significance of the office does not only derive from the sheer size and number of fee-earning architects, and the fact that the firm has produced iconic buildings around the globe, but also because Norman Foster has been awarded numerous prizes,<sup>17</sup> and was honoured with a life peerage, taking the title Lord Foster of Thames Bank. All of this produced recognition, professionally within the architectural domain, commercially and publicly (outside the architectural profession) as urban and cultural geographer Donald McNeill (2005) analyses. With a view to this, McNeill points out the importance of public communication in the form of marketing and public relations to the office. It is said that Foster is largely in control of publications and has an 'extraordinary influence over British architectural critics' (Moore 2002), and as a result what we can learn about the Sainsbury Centre from the body of literature descends largely from the office or has been published with the approval of Foster + Partners.

Furthermore, the office is very active in publishing: there are extensive volumes, an on-going series dedicated to the Complete Works of Norman Foster edited by David Jenkins (Jenkins 2002–), monographs on selected projects, an anthology of writing on Foster, and by Foster (Jenkins 2000), as well as the biography *Norman Foster: A Life in Architecture* by Deyan Sudjic (Sudjic 2010) to name only few. Each of these examples discusses the Sainsbury Centre in detail. The most comprehensive presentations can be found in *Norman Foster: Buildings and Projects of Foster Associates Vol. 2 and 4* (Lambot 1989, 1996), *Norman Foster: Works 1* (Jenkins 2002), and the

---

16 The building has received a number of awards, amongst others: British Tourist Board Award; R.S. Reynolds Memorial Award; 'Museum of the Year' Award; Ambrose Congreve Award; 6th International Prize for Architecture, Brussels; Structural Steel Finnieston Award; Royal Institute of British Architects Award; LABC East Anglia Built-In Quality Award – Best Public Community Project, Highly Commended. In 2012 it became a Grade II\* listed building (Department for Digital, Culture, Media & Sport and Vaizey 2012).

17 Amongst them the Royal Gold Medal for Architecture (1983), the American Pritzker Architecture Prize (1999), the Japanese Praemium Imperiale (2002).

monograph *Sainsbury Centre for Visual Arts*, Foster + Partners (Foster and Powell 2010).

Consequently, when turning to the body of literature on the building one is continuously led back to Foster. Here we find the narration of the star architect that takes us into the world of ideas of the creator and his biography. This is a meta-level form of explanation that tries to understand how Foster came to build this structure. We can additionally turn to the larger socio-cultural framework, which guides us into his childhood in a working-class environment, and leads us to the USA and the people he met there while studying. Furthermore, this touches on Britain's emergence from the war, the building politics and the driving utopian power of the young architectural scene during the 1960s and 1970s in the UK. We can learn about Foster's passion for aeroplanes and bicycles and his friendship with architect and inventor Richard Buckminster Fuller. If we were to try to explain how Foster came to be the architect he is, however, we would quickly lose sight of the building he constructed.

Another path closely related to Foster is a rich reference system that is mobilised around the Sainsbury Centre. When reading the office's publications on the building references can be found that were explicitly taken during the design phase and references most likely added after it was completed. Three buildings are most prominently alluded to: the Jutland Art Museum at Ålborg by Alvar Aalto (1972), the Louisiana Museum of Modern Art in Humlebæk near Copenhagen (opened in 1958) and New National Gallery (1968) in Berlin by Mies van der Rohe. On a four-day study tour, Lisa and Robert Sainsbury visited these buildings in September/October 1974 together with Wendy and Norman Foster. All of them said to be inspiring and influential to the design process of the Sainsbury Centre (Powell 2010; Rybczynski 2011): The Jutland Art Museum affected or at least coincided with the selection of the remote site next to the woodland and was admired for its use of top lighting and practice of flexible screens to subdivide the main exhibition area. The Louisiana Museum of Modern Art was regarded for its informality, while the security standards and access to storage facilities seemed problematic. Finally, the New National Gallery in Berlin, albeit seemingly inappropriate as a model, is said to have, however, served Foster as a reference for a flexible building structure—and one that maintains openness to the future. As such, these references influence the design process just as other constraints, for example the site or the economic situation, suggest certain solutions. The site conditions with a sloping terrain recommended lining the building programme along the existing access road and while the different functions of museum (comprising permanent and special exhibitions), school of fine arts, restaurant and senior common room (abandoned later) suggested several separate buildings, the comparatively low budget for the construction and in a period of steep inflation in Britain a single open plan building seems to be an economic solution (Rybczynski

2011). Moreover, the open plan solution was something that previous projects had developed and had successfully proven several times.

Other connections concern the proximity of the initial ribbed aluminium panels of the façade to the Citroën 2CV and the Airstream caravan designed by Wally Byam (Lambot and Vickers 2002, 398–99). Furthermore, the resemblance between the service catwalks in the roof plane of the Sainsbury Centre to the service gangways in the airship Graf Zeppelin and its ‘structural lightness’ in general (Powell 2010, 26) has been mentioned in the literature, as has the Boeing 747 galley as an example of ergonomic efficiency presented next to photos of the dark room and lavatories of the Sainsbury Centre (Lambot and Vickers 2002, 384). These and other comparisons and ‘sources of inspiration’ accompany the project descriptions. Whether or not these images were already circulating during the design process cannot be determined with any objectivity anymore. It would be a separate work to study the active role of these kinds of images in the design process. If present, however, we must not understand them as mere passive sources for human inspiration but as active influences: supporting, redirecting and shifting design trajectories.

Thus, it can be stated that the building, like any other architecture, is shaped by numerous demands and influences. As any project, it develops along a meandering trajectory and is of course never the work of a singular star architect. In the end, it is highly problematic to determine a building on the basis of a narrative of the creative genius, which is produced by the system of architectural stardom. McNeill’s analysis of Foster + Partners traces processes of architectural globalisation and questions the singular authorship produced by this system (McNeill 2005). As discussed earlier (Chapter 1), given the complexity of the design process the notion of ‘starchitect’ is highly reductionist. As Yaneva shows, however, not only complex human reference systems have to be considered (Yaneva 2009a, 2009b).

Before we remove the architect from the focus in the following, two remarks should be made here: Since Foster + Partners are, as noted above, largely in control of the publications about the building we also have to consider these images as tools for a referential game with historians of art and architecture. The addition of images of the Citroën 2CV or the airship Graf Zeppelin to the project explanations, suggests a reference system in which the building is to be deciphered today. In doing so, they actively take the authority to interpret their buildings.

Foster has decorated drawings of [his] buildings with helicopters or else his pure-white Caproni sailplane gliding overhead. These intrusions are significant. Most of Foster’s best buildings are elegant machines, either complex in form (like the Renault Centre) or else simple, smooth skinned structures like a glider (Sainsbury Centre). (Glancey after Jenkins 2002, 387)

Even small hints like the sailplane gliding over the building give incentives to the chain of interpretations. It is a referential game—a giving and taking of references with architectural critics and theorists.

However, Foster does not only have the far-reaching interpretive authority, but also, and this is quite unusual within the field of architecture, he still has great influence on all changes that are made to the building to this day, as we will see in the next chapter. As such, we will meet him again in the building but no longer as a starchitect who hovers over it but in his worldly influences on concrete decisions and spatial processes. The special relationship between building and architect can be partly explained by the importance of the Sainsbury Centre for the course of Foster's career, but it is also certainly based on his relationship with the founders, which elevated the building to a work of art.

### 3.2.3 ... a Piece of Art

David Sainsbury ends his foreword to the catalogue *Superstructure: The Making of the Sainsbury Centre* with the words: 'my father always used to say that it [the building] was the best object in his collection.' (Sainsbury 2018)<sup>18</sup> The building, as a piece of art, is part of a narrative that describes the founders' close ties with the artworks and the individual artists with some of whom they shared lasting friendships—Norman Foster amongst them. In his book *The Biography of a Building: How Robert Sainsbury and Norman Foster Built a Great Museum*, architect and writer Witold Rybczynski provides a particularly noteworthy insight into how the collection, and the desire to ensure its afterlife, led to the founding and building of the Sainsbury Centre (Rybczynski 2011). The book opens with the acquisition of the first works of art by Robert Sainsbury, a pair of drawings followed by the small bronze sculpture *Baby Asleep* both by Jacob Epstein (*ibid.*, 24ff.). What starts with a small rebellion, following Rybczynski, within a seemingly aesthetically and artistically alien upper-class family, develops into a full-grown collection which contains today over 1400 items (Sainsbury Collection 2018a). The collection comprises works of African 'tribal' art, the Pacific, the Americas, Asia, and the ancient Mediterranean cultures, and furthermore includes some important works of European modern art. Next to Jacob Epstein, Henry Moore had been one of the first acquisitions; Pablo Picasso, Alberto Giacometti, Amedeo Modigliani and Francis Bacon amongst others should follow (Hooper 1997). The Sainsburys had lived with the art in their house in Smith Square in London, arranging it to aesthetic criteria. When announcing to give the group of 500 works of art (at that point of time) to the relatively young University of East Anglia this idea was also driven by the wish to keep the collection together instead of splitting up the eclectic group of art-

18 The catalogue was published in association with the exhibition *Superstructures: The New Architecture 1960–1990*, on the occasion of the 40th anniversary of the opening of the Sainsbury Centre on show from 24 March until 2 September 2018.

works, as would have been most likely the case at other Universities with existing collections. This story of the domestic environment and the close connection of the collectors with their acquisitions and the artists, but also of a nonconformist couple who did not see themselves as collectors, we will encounter again when approaching the building in practice (Chapter 4).

Prior to giving the impetus for the construction of a building, the Sainsbury's collection had been exhibited in the Rijksmuseum Knöllner-Müller in the Netherlands in 1966. Here the art was presented in an unorthodox juxtaposition of modern, ancient and 'primitive' or 'tribal' art—for the first time presented to the public. Kho Liang Ie designed the exhibition layout, which would serve as a model for the Sainsbury Centre by allowing for the viewing of objects from all sides, the use of small labels and reserved colours. The Sainsbury Centre differs from the above examples, however, in that it integrates university facilities into the museum, a decision that was made early on in the project to ensure an entanglement with the life of the university. The project starts to take shape once the architect is introduced. Rybczynski describes the progress, touching on controversies, particularly during design and construction between the patrons and the university but also after its inauguration.

Rybczynski's book provides the most comprehensive description of the development of the Sainsbury Centre for Visual Arts. Its importance, however, also lies in the fact that it is still being sold in the building today and it can be assumed that, in addition to the Sainsbury Centre website, it is an important source of information for the staff as well as for visitors. Based on interview material with central figures, sponsors, planners, clients, historic witnesses and present users as well as reflecting on archival data, Rybczynski presents the building in its historical evolution and shows how it is intertwined in a network of interests. As the subtitle *How Robert Sainsbury and Norman Foster Built a Great Museum* already suggests, Rybczynski puts emphasis on the relationship between the patrons, and the architect. To a certain extent we can read this (commissioned) book as a success story of two gentlemen. Rybczynski himself remarks that 'great architecture does more than simply enclose, of course: it creates an interior world' (2011, 213). Moreover, he holds the Sainsbury Centre to be 'a congenial setting for human activities: looking at art, studying, eating lunch, staring out of the window' (221). That said, he does not close in and focus on detail. And while it is entitled a 'biography of a building', the building as an actor is less important to his explorations than the human protagonists. Whereas we learn much about the Sainsburys and Foster, this stands in stark contrast to what we *do not* learn about: the special qualities and reciprocal relationship that occur *with* the building. Although the process of creation is revealed here and various turns in the design process as well as the conversions after the opening exposed, the understanding of the building as a rigid object that forms a mere 'setting for human activities' is reproduced. The

rich experience of the daily life of and with the building is missing. As such, this belongs to a traditional discourse about a building that contains space similar to the countless building reviews which all rather move around the building reproducing the same iconic images, presenting historical developments, technical details and aesthetic impressions, next to stylistic classifications (Peckham 1979; Sudjic 1986; Jenkins 2002; Pavitt and Thomas 2018a). They give little or no insight into the rich field of interactions and possibilities that this building promises and most of the associations between human and nonhumans remain invisible. That said, at least doubts and clues can be found that point to the worldly reality of the ‘work of art’.

When opening, the building caused controversial attention—on campus, in the general public, amongst practitioners and academics. During the three day inauguration, 6–8 April 1978, students demonstrated against the building and handed out ‘a Marxist pamphlet denounc[ing] the Sainsbury Centre as a “monument to the bourgeoisie” and a “costly white elephant”’ (Rybczynski 2011, 151). The building was not only contentious amongst students who had recently experienced cutbacks in the financing of the universities, concerns which were shared to some extent by the staff and lecturer’s union, there were also reservations on the part of the university already before the building was opened about the smooth metallic appearance that was in stark contrast to the adjacent concrete architecture, as well as about the location of the offices inside the building without direct access to daylight (Dormer and Muthesius 2001).<sup>19</sup>

Amongst the critiques of the Sainsbury Centre, Martin Pawley’s *Buildings Revisit* stands out. Celebrating the ‘neutral timelessness’ (Pawley 1984, 44), he hints at the material deterioration, problems with heat loss and air pressure and by consequence the instable climate, which he indicates cause difficulties for potential exhibitors and in getting loans for exhibitions (ibid.). As the architectural critic Rowan Moore describes, the building as ‘illogical’, ‘creat[ing] a space too vast for the delicate exhibits, and caus[ing] problems in the acoustic separation of exhibition, teaching and eating’ (2002). These are rare moments amongst the existing reviews, which allow a brief glimpse into the building’s life. Another rare account which furnishes a critique from ‘inside’, from people working and experiencing the building on a daily basis is provided by Muthesius and Dormer (2001). Architectural and design historian Stefan Muthesius, who as a teacher moved into the Sainsbury Centre when it opened, published in 2001 together with Peter Dormer, who for his part had experienced the building as a fellow in the

---

19 The magazine *Architectural Design* in 1979 dedicated one issue to the Sainsbury Centre with a detailed critique by Andrew Peckham supplemented by invited comments (Beck 1979).

School of World Art Studies and Museology (1994–96),<sup>20</sup> on the architecture at the UEA. They report on the mundane problems comprising the sound insulation of the offices for lecturers, the initial lack of lecture halls, the door-locks embedded in the floor (forcing the users to bend down for unlocking) and high temperatures during hot summer days (Dormer and Muthesius 2001, 32–35). These problems, most of which were solved in later refurbishments, are not interesting because they make the ‘masterpiece’ a worse or a less beautiful one, because they do not tune in to the praise of the starchitect, they are interesting rather because they point out the simple practicalities of the building in practice. There is a pragmatic way of knowing the building. The building is connecting one lecturer with the next behind the wall by audible transparency, it is forcing people to do certain movements when opening doors, and allowing or hindering assemblies of people by providing appropriate locations.

### 3.3 Approaching the Building in Practice

Foster Associates did not create a sequence of rooms for the different activities but used an open plan typology that does not utilise walls as a tool of spatial organisation. Hence, reading the plan and talking about the spatial layout does not tell much about the lived reality of this building. However, we gained a first idea of the overall organisation and the different parts that make up the building. We understood for example that the double shell and the underground corridor are important to allow for the type monospace to emerge and that the Sainsbury Centre is not simply an empty box but structured into areas with different layouts and material qualities. Nevertheless, this understanding remains abstract and developed in diagrams. How people meet and move and how they interact with the building, the art, and the multiple objects, which are granted with a special presence inside this monospace remains open.

Discussing the building through its aesthetic qualities and relevance and taking up the many concepts that exist around open plan architecture may indeed seem interesting, just as assigning the building to stylistic periods or historical developments, but this simply reproduces a formal object located in space and in time. We do not get access to the processes the building is part of. Yaneva suggested turning to the controversies and following how the building holds these sometimes seemingly contradictory aspects together (Yaneva 2012, 2009b). Then, approaching these contexts is not a question of following interpretations and opinions but of

---

20 The name of the school changed several times. Today it is the department of Art History and World Art Studies.

understanding that the building allows for discussion of all these different aspects, giving it new depth and direction. Hence, we can follow these discourses without trying to understand what the building is (in terms of definition) but rather by what it does.

My focus, however, remains with the question of space. And particularly with space 'inside' the building as this is how we so far have come to know the type of monospace—it contains one space inside. Yet as I argue, the monospace demands that we turn to the doing of people and objects, of building and practices if we want to understand its architectural quality. This quality is not conceptual and abstract but emerges from 'within'. Thus, I aim at looking beyond the building as a solid object by focusing on mundane practices with the building, today. Given the apparent simplicity of the typology of monospace, it is tempting to believe that these buildings are easy to understand. This is only the case if we turn to architecture as product or as a beautiful object in a collection. The critiques about noisy offices and missing lecture rooms remind us about the everyday networks the Sainsbury Centre is part of. It does not reside outside the social but the social is one of the many dimensions of the architectural process. It is particularly with the monospace that we need to understand and get a better grasp on architecture as a process and as such as something that is never finished. To comprehend the building in its architectural quality we have to move closer.

So, let us take up the trail of ANT that we left behind in the course of this chapter. I claimed that ANT allows empirically investigating the joined doing of people and building and thus provides access into the rich and ephemeral world of monospace buildings. Leaving the container thinking behind and turning to spacing we approach the Sainsbury Centre 'in practice' in the following chapters. By following spacing, the social life of the building—tracing how it connects in interaction, how it shifts and supports certain courses of action—will arise. By uncovering what it does, we will be able to gain a different understanding of what this building is.



## 4

# In Practice I: Working-With

---

After devoting ourselves to the literature about the Sainsbury Centre and gaining an overview of the various approaches to and narrations about the building (as a piece of late modern or high-tech architecture, as the first public commission of a starchitect, as the work of two great men and ‘the best object in the collection’) we will now shift focus. In the following, we turn to the building itself and approach it as an actor. This may sound confusing at first, as we have not only just studied the many contexts, but also the plans, the materials, and the functional organisation of the building. We were able to understand the three-dimensional body, its materiality and structure and in this way, developed initial ideas about the effects that the building and its elements could have. Yet, these ideas are based on simple causal explanations that we extract from the diagrammatic body. To escape a linear cause-and-effect relation that lies at the root of a deterministic architectural thinking these assumptions need to be tested and verified ‘in practice’. Thus, we will now move closer in order to understand the earthly reality and to trace the complexity of the Sainsbury Centre. Here we find the building as an actor on the move, which does not dominate but take part in mutual interactions while being exposed to constant negotiations.

The lack of structural spatial separation in a monospace seems to allow for infinite possibilities of experimentation. Monospaces suggest an architectonic openness to change. Designed and promoted as a building of extensive flexibility, how does the Sainsbury Centre relate to time, processes of change and transformation? Let us explore what modes, mechanisms, potentialities, and limits become visible when approaching the building in practice. The approach to look from inside out, to use an experiential perspective in a pragmatic way (see Chapter 2.3 and 5) is very different from the previous chapter and we will leave the focus on the building as a static object behind. With this chapter we turn to ‘the continuous flow that a building always is.’ (Latour and Yaneva 2008, 81) Space, in the flow of a building, is not contained but constantly re-thought, re-shaped, re-transformed according to many material arrangements, different sets of practices, and movements of people

and objects. Thus, we will focus on the relationship between building and people and distinguish different ways they share agency during spacing. ANT is particularly helpful here because it makes possible the investigation of doing in common and provides us with a vocabulary with which we can address the different ways of sharing agency.<sup>1</sup>

We will enter this world of spacing together with Calvin Winner, Head of Collections and a Senior Curator at the Sainsbury Centre, and at the time of the interview additionally Deputy Director. The interview was conducted during a walk we took together in the building without any pre-defined route. Walking interviews create a very site-specific setting and provide a rich amount of data, as previous studies have shown (J. Evans and Jones 2011). Moving in the building in the course of the interview promotes leaving a linear narration behind and turning to the material world. Here we learn how the building is not a singular object but made up of many different ingredients that connect in many different ways. Winner gives an insight into how *they*, the employees of the Sainsbury Institute for Art, work *with* the building. The building shapes, facilitates, and permits daily life in a very particular way. Listening to Winner and his colleagues, we learn about their specific engagements and see the rich and different characteristics and possibilities of working with the building.

Isometric diagrams accompany this chapter. They show the route of the walking interview and present parts of the actor-networks we encounter at a specific spot during the interview. I understand these drawings as a navigational tool, since we face a great complexity once turning to reality. They do not reduce the building to static freeze frames but build a connection by offering a simplified or reduced point of anchor, permitting the travelling between in-depth encounters.

Besides the walking interview, for this chapter I draw on a broad range of in-depth interviews with people who are engaged with the Sainsbury Centre on a permanent bases. Furthermore, I draw on my own observations during the walking interview and during my research stays at the Sainsbury Centre in general. All of this allows to witness different processes of transforming the world of the building, some major reconstructions, others minor replacements or technical improvements, and again others that change courses of action (some of which leave the material world unchanged). Here, we enter into historic notes about the origin or biography of the elements that make up the building; however, I will only pick up these traces where they make a difference today. With this chapter, we will get an insight into the work of actors who are in permanent relations with the Sainsbury Centre and the possibilities of understanding spacing when following their working-with. With the help of ANT we can differentiate ways the building

---

1 Approaching the relationship between body and building, Yaneva introduces different ways of distributing agency and gives an overview to the relevant literature (Yaneva 2009c). See also Latour, *On Technical Mediation* (1994).

shares agency in the process of spacing and thus gain an understanding of which roles the building and its elements have during these processes. Before heading off with Winner let us take a look at the route and our guides.

## 4.1 Taking a Walk: Introduction to the Guides

Calvin Winner has been working at the Sainsbury Centre for 11 years (at the point of interview). He is knowledgeable about the historical developments and has been involved with most changes around the building during the last decade. Winner is responsible for all curatorial aspects concerning the museum art collection and temporary exhibition programme. He knows the Sainsbury Centre on a day-to-day basis; however, his role has changed throughout this long period of involvement. Winner was so kind as to explain himself, willing to give a tour through the whole building, and notwithstanding that this is not a short undertaking, remained patient and opened the last doors in the basement to show warehouses of discarded lamps or the freezer for objects potentially infested with vermin. The walk lasts until early evening, disrupted and cut into pieces by several other obligations.

The aim of the walk is to see all parts of the building, especially those I might not be able to enter on my own. As agreed upon, a certain amount of focus is always given to recalling changes, modifications, and the flexible usages of areas, elements and objects that might not tell their story on their own. While the tour leads through the whole building, I will only mention three significant stops at the beginning of the tour. The first stop is downstairs in Gallery 1, the next in the East End Gallery and the last stop in the middle of the Living Area.

Such a selection takes Winner's roles and activities into consideration. Above all, Winner is concerned with the curatorial aspects to the permanent collection and the temporary exhibitions. This is the background to his narration and argument. If we consider this, it becomes clear that the selection of stops on the tour in the galleries are important anchors to his engagement with the building and that this is where we can learn the most from him. Thus, while my tour with Winner runs through the whole building there are areas he is engaged with on a daily basis through his activities. In contrast, other areas, like the school between the two mezzanines for instance, do not belong to his roles and daily activities and he therefore only makes mention of these areas by pointing to the respective function or giving me a brief explanation or even does not mention them. Thus, the three stops that we will explore give us the opportunity of witnessing best how Winner is working with the building.

While Calvin Winner guides the tour, he is however not the only guide. There are things that stop us; anchor points that remind Winner to talk about specific issues, and points of attraction that catch his or my attention and redirect our conversation.<sup>2</sup> Thus, it is not only Winner choosing where to turn and what to tell it is also the building and the many things that navigate this interview. This is why a walking interview is a particularly suitable method to approach a building. In in-depth interviews, I often face large narrative overviews, official interpretations and accounts, while in a walking interview the things themselves have an impact, remind the interviewee about details he/she might have forgotten about otherwise.<sup>3</sup> Nonhumans can also assert themselves, prompting their spokesperson to make mention of them. Thus, the mode of the interview does not only approach a spokesperson for the building in a more or less detached setting, but faces the complex world of the building and allows for a more *realist* account of it. Even if Winner is guiding the tour, it is the building that conducts our activity.

In the following each section is dedicated to one stop and explores a particular fragment of the Sainsbury Centre. Each section starts with a sequence of the walking interview. Here we learn about Winner's experiences and engagements. He introduces different actors and concerns. And while Winner always takes the initiative, we will follow particular paths in more depth and take up other voices to then bring everything together in the analysis in order to see how this can contribute to our understanding of spacing.

The first stop, downstairs in Gallery 1, starts with the resistance to change present in the upper part of the building, the monospace. We learn that it would not comply with the wish to stage major temporary exhibitions. The new demands led to a new way of *working with and not against* the building. Following Winner into this world of working-with we quickly lose sight of external or contextual categories, which seem incompatible with or not of concern in the practical reality of the building (as long as they are not visible, do not interfere and thus become actors themselves). A flexible space, it becomes apparent, is nothing a building can possibly contain—a flexible space is the work of many and thus, moving on with Winner, we slowly arrive at an understanding of the different ways the building as an actor shares agency and how both humans and nonhumans can shift, distort, and redirect certain courses of action, certain spacings.

With the second stop, we move into the East End Gallery. We learn that with the creation of the new underground Exhibition Suite, this gallery was also rethought. If action is a 'knot' of 'sets of agencies' (Latour 2005, 44), in the process of

---

2 Guggenheim elaborates on how objects stabilise memory by 'doing remembering' and thus by building links to the past. He furthermore sheds light on the often problematic nature of making history (2009).

3 As such, it is a specific elicitation technique distributing the role of the elicitor into the environment walking about.

re-thinking this knot becomes loosened or unravelled—some strings vanish and new ones join and new courses of action become part of the life of the East End Gallery. A new network assembles and defines the East End Gallery in its (new) relatedness: in its rhythm of changing exhibitions, in its materialisation of temporary exhibitions. We witness how actors gain meaning through their relation and understand that precisely in these relations they can shift from unnoticeable helpers to obstructive hinderers in the course of action.

The third and last stop then, takes us into the Living Area. Here, we approach the relation of the intention of architects and patrons when planning and realising the building and in particular the Living Area and today's spatial practices. We pay attention to how the material arrangements and practices come together to stabilise the material setting and how actions for communicating the artworks change the processes of spacing in this area of the building.

## 4.2 First Stop: Gallery 1



**Fig. 4.1**

We had only walked a few metres, still downstairs, and recalled the purpose of the interview. We are in Gallery 1, which is the link between the upper building and the underground built in 2006, when Winner notices 'I mean

there is a lot of flexibility in everything, but I guess increasingly with parts of the building now being listed there are complications.' The listing only includes the 1978' building and not the part we are in at that moment. He points out that the connection between the two parts is open plan and thus if they would wish to change something in this gallery 'there would still be a need for a certain permitted development'. When the extension was done in 1991, the Sainsburys did not want the Centre to be closed during construction. Winner says, as the extension was almost conceived like a separate building, it would be interesting that now the listing would treat it like that again even though the building today, is linked by an opening that is joining 'the two halves, the two parts of the building'.

We stop at the connecting point between downstairs and upstairs next to the spiral staircase that leads up into the monospace. Two rectangular holes in the ceiling connect the two building halves. A Gallery Assistant is coming down the stairs; we greet him. He will replace a colleague situated over here to control visitors entering the Exhibition Suite.

After the appointment of the recent director (in 2011), Paul Greenhalgh, new strategic directions were formulated Winner continues to explain. The outcome was the desire to create an exhibition suite downstairs to be able to obtain major art loans. '[O]ur institutional reputation was suffering, constantly having battles with insurance and lenders over the conditions upstairs', he elaborates. The shop that used to be located over here, as a consequence, but also out of commercial considerations, had to move upstairs. Winner describes this process of decision-making and the demand for changes coming from the Sainsbury Centre staff, as 'quite new', 'quite interesting', and 'quite tough'. They started to formulate opinions and views and got into debates with the architect and the funders—this time more out of a client's position.

To stage major exhibitions, Winner elucidates, you need climate-controlled space, which could not be achieved with the big open plan space upstairs—that is, not within reasonable efforts: 'We are trying to make the building do things that it doesn't want to do. You have to work with the building, not against it. [...] Once we kind of exposed that, there was clearly a logic to start changing spaces.' The underground extension thus 'helps to support the idea that it is a flexible building, which isn't always true of course.'<sup>4</sup>

---

4 Winner, Calvin (Acting Deputy Director, Head of Collections and Senior Curator, SCVA). Walking interview by Sabine Hansmann. Norwich, 4 November 2016.

### 4.2.1 Two Building Parts?

Let us take a little break here. ‘We are trying to make the building do things that it doesn’t want to do. You have to work with the building, not against it.’ What an outstanding testimony to the involvement and cooperation with a building. We will get right back to that, but let us start at the beginning. Winner stops and is stopped by the connecting point between downstairs and upstairs. So, what do we find in this sequence of the interview? There are different key themes: Firstly, the extension of the building, the listing of the old upper building part, and the connecting point between upstairs and downstairs, old and new (where we are stopping); secondly, the redevelopment of the underground into an exhibition suite, which is connected to the appointment of Greenhalgh and the re-location of the museum shop upstairs. Winner provides historical information about the spot we are stopping at. Pausing at the staircase that connects the underground and the upper building is not randomly chosen but it is the location of the most recent, most radical re-thinking and material transformation of the building that Winner and the building both were involved with. In the sense that this transformation was a constructional intervention, indeed, our tour takes off with a traditional architectural subject and is moreover concerned with historical development. Buildings are constructed, reconstructed, and extended. However, Winner is also hinting at connections that he seems to find strange or remarkable and introduces new, or so far unmentioned actors who took part in the process of redevelopment.

Right from the outset, Winner points out that Historic England when listing the building under Grade II\* on 19 December 2012 treated the building as consisting of two buildings, only including the building parts that have been built 1978 under the listing.<sup>5</sup> So why is it remarkable that Historic England includes only the old building parts? One of the official reasons for becoming listed is the following:

Flexibility of design: the in-built flexibility of its open spaces responds to the changing needs of its use as a museum gallery and education centre. The design has allowed regular, sympathetic changes to work satisfactorily, and the essential elements of the building survive intact. New additions and alterations, while too new to be of special interest, have been thoughtfully incorporated. (Historic England 2017)

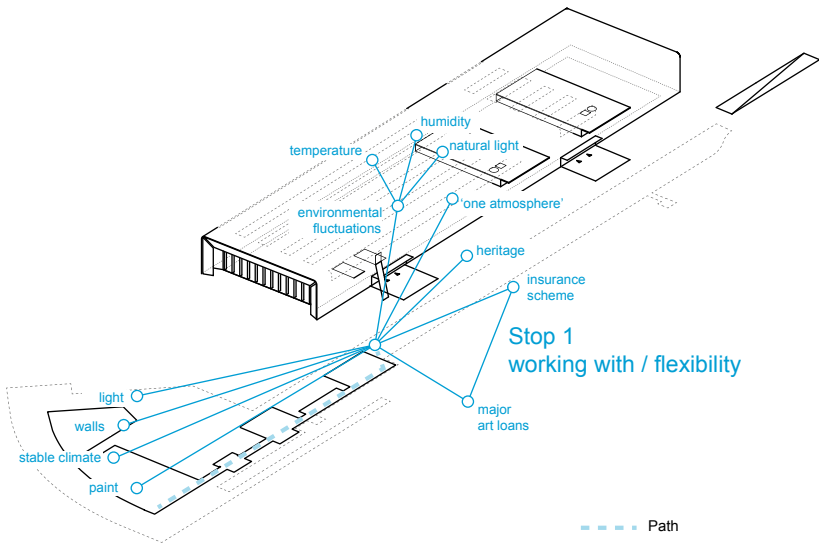
The new underground building part is simply too new to fall under the listing. It does not seem surprising that an age classification is applied by Historic England. Winner’s point, however, seems to be of another sort: He says that the listing would treat the building as almost two separate buildings, just in the way they

---

5 The listing followed the decision by Heritage Minister Ed Vaizey, after advice of *English Heritage* (Department for Digital, Culture, Media & Sport and Vaizey 2012).

were originally built. Today they are indeed connected by the two holes with a grand steel staircase that we stand beside. Furthermore, he mentions that the listing added complications and that—because there is the connection—they would also need ‘a certain permitted development’ to change the parts that are not listed. And this hints at the practicalities that this listing includes. While from the outside, approaching the building by its age, a historical categorisation, is common, this does not correspond with the experience of daily life with the building. Here, it is less important how old one or another part is. Thus, it is *not* about rigid categories, but what differences these parts do or how they work together.

When approaching the people who experience and work with the building every day, the question of whether there is one or two buildings disappears. It becomes more important how they can relate to them. Here networks are formed and agencies are shared (see Chapter 2.3). Thus, following the principle of working-with opens us to different ways of how Winner and his colleagues share agency with the building.



**Fig. 4.2:**  
First stop and actors.

### 4.2.2 Working with the Building

Winner recalls the history of the corridor, which was only built in 2006 as an internal public link between the upper building and the underground Crescent Wing (opening 1991; see Fig. 3.7). This connection, as well as the former underground extension and other modifications, mainly took place under the guidance of the



funders and the architects. Here, Winner distinguishes the last strategic re-thinking (in 2012/13) that happened after the appointment of Greenhalgh. While the Sainsbury family and Foster + Partners were also involved in this change, the staff of the Sainsbury Centre Institute formed a new or so far at least little-noticed actor: the client who demands change as a spokesperson for and out of the daily work with the building: 'You have to work with the building, not against it.'<sup>6</sup>

Re-thinking the building, in this case, was less concerned with the material world than with the immaterial world of the building—it is not primarily the form that does not lend itself to the changing demands and new ideas of staging major temporary shows but rather the climate in the upper part of the building. As we have learned earlier, the monospace is not air-conditioned (see Chapter 3.1.3). And here Winner introduces two other actors, the insurance scheme and the lenders. Amongst others, a stable climate is required for an exhibition to fall under the Government Indemnity Scheme which provides cost-free indemnity to art loans apart from commercial insurances (Arts Council England 2016). The upper part of the building is not able to fulfil the requirements—it does not permit the borrowing and staging of expensive pieces of art as it does not meet the demanded conditions of the Indemnity Scheme, which is important for an institution like the Sainsbury Centre for staging temporary exhibitions. A stable temperature but far more important humidity and light are major concerns in museum environments to prevent damages to artworks (Thomson 1994).

'We are trying to make the building do things that it doesn't want to do. [...] Once we exposed that, there was clearly a logic to start changing spaces.'<sup>7</sup> Making the building do things that it does not want to do, could have included major climatic and energetic redevelopments of the upper building part. Yet, dealing with a monospace this would have been a far-reaching decision as it concerns the whole building and its networks, as one cannot change only a section of the climate. Indeed, the new objective of staging major shows could have led to radical material modifications. In this, every new demand and objective involves a destabilisation of the spatial setting, concerning both material and immaterial spacing devices. In the process of re-thinking, of virtually testing the possibilities of new spatial arrangements, they decided working-with the building and following the opportunities that it provides: While 'upstairs the control of the conditions is rather more passive [...] the downstairs spaces gave us this big controllable space to host major shows'.<sup>8</sup> A path of minor material modifications is chosen, which relocates major temporary exhibitions downstairs and leads to new distributions of objects and people throughout the building.

---

6 Winner, walking interview.

7 Winner, walking interview.

8 Winner, Calvin. In-depth interview 1 by Sabine Hansmann and Maria Lisenko. Norwich, 2 November 2016.

In the process of decision-making and re-modification, there are not only humans who contribute. Re-thinking the material arrangements, the building offers some possibilities and impedes others. The ‘programme of action’ is formed in negotiation with the building and here new possibilities arise (Latour 1994, 32). The building as an actor emerges. However, it is not the building as a single thing, but different materials and technologies: for example the low mass of humidity and temperature buffering materials, the high ceiling of the shell and numerous thermal bridges and areas with single glazing in the shell of the Sainsbury Centre. They influence the decision and thus contribute to the formation of new material arrangements, which become new ingredients of spacing.

### 4.2.3 Flexibility: The Work of Many

According to Winner, the existing air-conditioning downstairs was one of the key arguments to re-develop the underground part of the building. However, the new Exhibition Suite allows for a fundamentally different way of working with a whole series of things. Paul Greenhalgh, the director of the Sainsbury Centre since 2011 points out that ‘the one problem with the beautiful single space is that you can never escape from it, which means that if you want to set a different kind of atmosphere, it’s difficult to do that.’<sup>9</sup> This is what the new Exhibition Suite downstairs allows for: working with the floor, the walls, the paint, the climate, the light, with adding architectural elements, Greenhalgh explains. ‘So now we think we have the perfect flexible space’ to do so, which in size is said to be the largest temporary exhibition space in Britain and which does not interfere with ‘the single space—the integrity of that is very important’.<sup>10</sup>

To put it briefly, the underground transformation created ‘the perfect flexible space’ for major temporary exhibitions,<sup>11</sup> which left the upper part of the building unchanged and ‘helps to support the idea that it is a flexible building.’<sup>12</sup> This is a striking development for a building which amongst other things became listed because of its ‘in-built flexibility’ (Historic England 2017) and which is said to realise ‘the dream of the infinitely flexible and perfectly conditioned art gallery’ (Banham 2000, 85).

Approaching the Sainsbury Centre from afar by reading about it and studying the plans, indeed at first glance, the monospace in its form seems to be the perfect flexible space. We will have to reconsider this. A building never acts alone but is involved in innumerable associations and this is what we do when we approach it and move inside it following the people engaged with the building on a daily

---

9 Greenhalgh, Paul (Director, SCVA). In-depth interview by Sabine Hansmann. Norwich, 10 August 2017.

10 Ibid.

11 Ibid.

12 Winner, walking interview.

basis. This is of course not surprising, and architects especially know very well that we cannot determine what a building is and what a building does by looking at its static abstract structure. A building is far more than that, and so likewise, it should come as no surprise that the monospace turns out to *not* be the perfect flexible space but rather the new underground areas. Space is not contained, a building *does* space with many other actors together, and so creating a flexible space is a task in which many are involved. Working with the building in re-thinking, reshaping and negotiating material arrangements and sets of practices to create a flexible space, comes about in and through shared agency. Thus, we have to unravel the different ways in which the building and its elements contribute to these agencies to understand how it contributes to spacing.

‘Working *with* the building and not against it’ left the upper building in its shell untouched.<sup>13</sup> Changing spaces in changing the paint, the wall, the light and the climate, the pieces of art (that are able to travel into the building under the Indemnity Scheme) is something the Exhibition Suite allows for. The rather conventional spatial layout in the underground and the monospace on ground level now complement each other, Winner explains: ‘The extension offers a further range of possibilities and opportunities. It complements what was there without destroying’.<sup>14</sup> Winner refers to the open plan connection of the two building parts, and in the course of the tour it becomes clear that we cannot think of these two parts separately, they never act in isolation. The point of connection, the two holes create the open plan link. They allow and hinder together with mobile barriers, with stickers as entrance cards, with Gallery Assistances humans and nonhumans to travel. With the introduction of the Exhibition Suite they now travel in new trajectories. The new Exhibition Suite is an active participant in the world of the Sainsbury Centre staging major shows like the *Paul Nash* exhibition in 2017,<sup>15</sup> drawing in new numbers of visitors. ‘In a space of about five years, the audience certainly doubled, there’s now around 100,000 a year, give or take. That element has been achieved, and we’re still looking to see that audience grow.’<sup>16</sup> However, this does not mean that the monospace is sunken into routine. In the same course of re-thinking upstairs functional changes also took place, which in fact were accompanied by material changes inside the building and also brought about new courses of action—new ways of spacing. Let us move on, upstairs into the monospace. What are the different ways the building and its elements share agency with Winner and his colleagues?

---

13 Ibid.

14 Winner, Calvin. In-depth interview 2 by Sabine Hansmann. Norwich, 12 August 2017.

15 This exhibition was organised by and previously staged at Tate Britain.

16 Winner, in-depth interview 1.

### 4.3 Second Stop: East End Gallery



**Fig. 4.3**

We walk up the spiral staircase, pass the shop, and our next stop is in the East End Gallery. Winner explains that this area used to be a temporary exhibition space and was changed into an extension of the permanent collection with the last modification phase. The reconfiguration was associated with the liquidation of the open storage area, an underground reserve collection that was accessible to the public. They had found that visitors were not really exploring it and today this material is shown on rotation in the East End Gallery. While the main display in the Living Area does not change (although art loans and minor rotations minimally change the setting), the main benefit of this extension is, Winner continues, that they could curate the space, add more text, have thematic groupings and have a different approach to what happens in the Living Area. This area would be in this sense complementary, it ‘allows freedom, flexibility to do other types of display’, which for example includes text-heavy displays. ‘So here we are a little bit more like a museum,’ he says and adds ‘the Sainsburys would hate that.’ However, Winner emphasises that he thinks they got the best of both worlds with these changes, as the Living Area still is ‘the heart of the identity’ of the Centre.

We move closer to one of the big display cases that have been newly designed for this area in connection with the rededication of this area. There are two different types: a big one and a small one. Winner says that David Rees has some issues with them and demonstrates: 'Now if you do this, you get very little movement [he gives the box a push]. In fact, I could give this a pretty good thump, and it would remain absolutely static. But for using the cases, they are really unstable.' The internal structure is not very rigid, he explains, and this poses challenges for setting up a display of ceramic for example.<sup>17</sup>

### 4.3.1 Defining in Relation

Standing with Winner in the monospace, it is not only that the objects serve as anchor points and affect our trajectory. The high visibility, the long uninterrupted view that the building allows for, also influences the mode of the interview as pointing to 'here' and 'over there' is enough to refer to different areas and devices. It does not seem to be necessary to move-on as Winner can address different issues from one spot: the East End Gallery itself and its relation to the Living Area or the display cases for example.

Once more there are historical notes about the development first. They show how re-thinking an area within the building is a re-thinking of specific ingredients of spacing and their relations. The East End Gallery used to be the temporary exhibition area. With the introduction of the Exhibition Suite as a new temporary exhibition area downstairs, the East End Gallery is able to take over new functions, which implies detaching old connections and building up new relations. In this process of setting up new relations, a new East End Gallery is formed which is characterised by its activity. Neither the new nor the old East End Gallery is a red encircled area on the plan of the building. Instead, listening to Winner, we can gain an understanding for the relatedness of this new actor in the world of the Sainsbury Centre.

In the first instance, the East End Gallery presents artworks of the permanent collection that used to be amongst others stored in the open storage area downstairs, Winner explains. Hence, this area allows showing art that would otherwise remain downstairs in the dark. Furthermore, it permits mixing in objects from other collections. Changing the type of display, changing the display cases and wall setting, and as Winner emphasises, including lengthy text explanations and grouping the artworks thematically. In contrast to the Living Area all of this is possible, he points out. It seems we can better understand what the East End Gallery is in relation to the Living Area. However, before we move on and explore why and how the Living Area is not flexible and does not allow for lengthy text

---

17 Winner, walking interview.

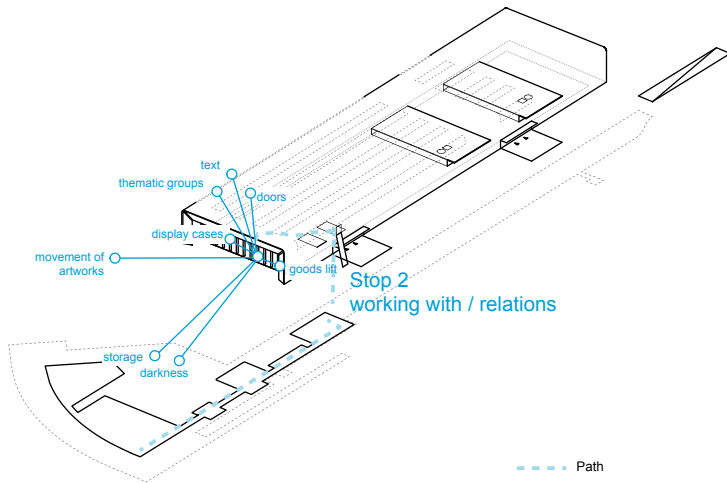
displays let us linger here for just one more moment. Winner explains that today this Gallery acts in a complementary way to the Living Area—complementary, in the sense of adding freedom and flexibility. Of course, once again it is not the area that holds the characteristics of flexibility and freedom, rather it is the joined practice of different actors that come together to circulate and present the artworks in changing constellations.

We can learn what distinguishes the East End Gallery by tracing its relatedness and its similarities and contrasts to other areas in the building. It allows a specific way of working-with for Winner and his colleagues. Here they are able to explore different thematic groupings, and draw connections to temporary exhibitions downstairs or on the second mezzanine. Thus, the rhythm of change relates to the coming and going of visiting artworks. Spacing in the East End Gallery happens in connection to the other exhibition areas.

Talking of *the* East End Gallery as a spot or an area in the building is a simplification that is indeed helpful to distinguish one area of the building from another. However, it is also black-boxing—we take it for granted.<sup>18</sup> Once one begins to open the black box of the building we approach many new black boxes. Yet, Winner introduces the East End Gallery in contrast to the Living Area by what it does. And standing there, surrounded by the material arrangement, it is impossible not to open these boxes and point to the different actors that actually do the work. This is a specific feature of the walking interview. We just need to look carefully, to listen and to slow down if we want to explore the different ingredients that do the work of spacing in this area. Indeed, Winner points to different actors that foster and impede certain courses of action.

---

18 It is this process of black-boxing ‘that makes the joint production of actors and artifacts entirely opaque’ (Latour 1999, 183). Each black box is made of many other individual parts, of which each is again a black box. It is an important aim of the school of social constructivists to open these black boxes of historical and contemporary technologies. Vice versa black-boxing is a mode of structuring or simplifying after having looked ‘into’ the black box to make sense of its complex realities (Bijker, Hughes, and Pinch 1987).



**Fig. 4.4:**

Second stop and actors.

### 4.3.2 Unpredictable»Mediator«

Winner hints at the issue of rotating and moving the art, which as we learn in the beginning is one of the beneficial aspects that the East End Gallery allows for. The circulation of the artworks is not only connected to insurance schemes, and museum environments, it is of course also about practicalities that allow or prevent artworks to take part in changes and material arrangements. And this brings actors of different material qualities together; Winner introduces two of them: David Rees and the new display cases. The former is said to have an issue with the latter.

David Rees is Head of Technical Services at the Sainsbury Centre who amongst many other things deals with the circulation of artworks in the building. ‘There are the challenges of getting things into the building’ he explains. ‘We have got this huge space in here, but you can’t actually get big things in because the biggest doors are just like a pair of ordinary double doors, [and] a non-functioning goods lift.’<sup>19</sup> Working-with the building is working with these access points in bringing things in and out. Unlike the building’s symbolic reference point, the aircraft hangar, the shell has no large gullwing doors that open the entire front of the building. There are only several pairs of standard sized double doors, one

19 Rees, David (Head of Technical Services, SCVA). In-depth interview by Sabine Hansmann. Norwich, 3 November 2016.

of which is located in the east end façade. The goods lift is also located there and connects the monospace directly to the underground service areas. These access points filter object movements in size and frequency. The goods lift is not broken, as one might think, but rather temporarily immobilised by the huge glass case that is sitting on top of it. This case is an obstacle and resists being moved given its size and weight as well as its inner structure that easily starts shaking. All of this makes it difficult to move and only becomes apparent when actually working with the case. A simple punch will not make it shake, as Winner demonstrates. The know-how required to operate the elevator has thus shifted into having the ability of moving the case. The glass case became quite a prominent actor, and most notably for the person working with it.

Both Winner and Rees, refer to specific devices that allow, hinder, and foster certain movements and interactions in connection to the building. This is how spacing takes place, with elevators, with exhibition cases, with air-conditioning, insurance schemes, and the rhythms of rotating artworks.

Thus far we have come to understand that the building and its elements take part in spacing, that they transform and foster certain spatial decisions, that they distort or modify certain courses of action. In addition, we have seen that a building never acts alone but that many are involved, for example in flexibility. Accordingly, it is clear that agency is shared and we have to look at the different ways in which the building participates, how its agency is manifested, in order to understand the different modes in which it participates in spacing. The distribution of agency is a core interest of ANT and here we find some guidance to unravel the different relations the building, its elements and the team around Winner have.

Following practices, the working-with, we approach the *multiplicity* of objects.<sup>20</sup> This is particularly evident in the example of the display cases: There is a beautiful super transparent case, which works smoothly in presenting art without obstructing light reflexes, as Winner explains at a different point of the walking interview. It invites people to explore the art, and I can observe visitors squatting, kneeling on the floor or crawling around the box under the spell of art objects in the example on the lowest presentation tableau. The case takes part in courses of action, however, it is important to differentiate the various ways in which it does. If it just conveys meaning in the sense in which input is equated with output without any transformation, then it is considered a smooth and predictable

---

20 Mol (2002) discusses reality as multiple, as something that is *done* rather than observed from different perspectives. Objects then are not multiple because of different points of view that can be taken on them, '[i]nstead, objects come into being—and disappear—with the practices in which they are manipulated. And since the object of manipulation tends to differ from one practice to another, reality multiplies.' (Ibid. 5) Foregrounding the practices out of which space emerges, spacing thus follows the trail Mol has laid down and forces our attention to the multiplicity of reality.



‘intermediary’ (Latour 2005, particularly 37–42). Intermediaries participate in courses of action and are predictable; therefore they can be defined prior to them. The case, like any other actor, can behave like a smooth intermediary. In the next moment, however, it can break down or turn into a disobedient ‘mediator’ (Latour 2005, particularly 37–42). ‘Mediators transform, translate, distort, and modify the meaning or the elements they are supposed to carry.’ (Ibid. 39) Thus, it depends on *how* the case is enacted and which network we turn to, to gain an understanding of an actor.

This is important for understanding the multiplicity and unpredictability of spacing.<sup>21</sup> There is also a heavy and (depending on practice) unstable box. It does not mean that mediators are always uncooperative. However, it is at the heart of their definition that they can only be defined in the process of action. Latour calls this ‘uncertainty about goals *translation*.’ (Ibid. 32) It is the *actor-network* the connections that the different actors have—the connection of case–lift–Rees–light–glass–visitor—that allows us to understand the *specific* display case and its specific contribution to spacing. Spacing is unpredictable insofar as all actors are multiple and have the possibility to distort, re-guide, and transform courses of action. Once understood, the building appears with its multiple elements and relations as hopelessly complex and relative. Where to start and where to stop? However, we have our guides who we should trust in making the right selection and indicating their important aspects.

---

21 Murdoch points out that ‘modes of ordering are never complete, closed totalities: they always generate uncertainties, ambivalences, transgressions and resistances.’ (1998, 364) Architecture’s *uncertainty* goes also to the heart of Till’s *Architecture depends* (2013).

## 4.4 Third Stop: Living Area



Fig. 4.5

We leave the East End Gallery and enter the thick skin, walk through the kitchen of the East End Café, and leave it past the counter. Winner touches on the little patio outside that he would like to make accessible—but there is the issue of how to access it without changing the interior conditions. ‘There was some discussion if it could become a sort of airlock but we actually think the solution is through the skin.’ Entering the skin again, we walk along the southern façade next to the Living Area and access it somewhere in the middle. We move deeper into the field of screens and cases. Winner explains that Foster + Partners would be very concerned about the height—2 meter for the white screens. And although this would not be high enough for many paintings of the Sainsbury Collection they stick to this height. Furthermore, the wall only appears to be flexible and movable but this is not really the case; that said; they are also not quite as sturdy as Winner and colleagues would like them to be. ‘They have a few kind of issues. It’s not so good but we kind of work with them.’ However, the height would be an important factor and part of the way the building operates, Winner emphasises and explains, ‘it provides that sort of domestic quality that is bizarre in such a

massive building to have a sense of intimacy with the objects. You would not expect it until you come here. [...] Well, clearly the heights are doing something, and I would not underestimate that. So we are really keen to retain that.<sup>22</sup>

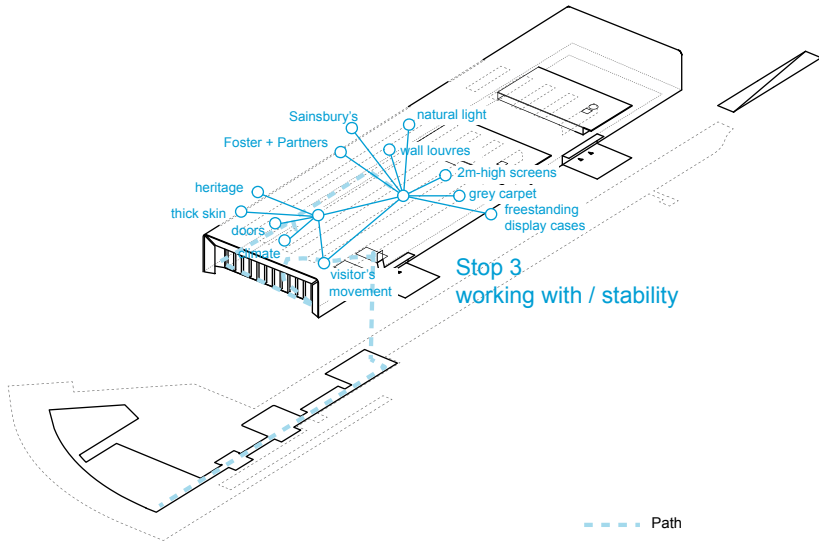
#### 4.4.1 Stopover: A Connection to the Patio

Walking into the Living Area and pausing there in the middle, we take a little stopover. There is the idea of creating a link to the little patio in front of the East End Café, and we encounter again the climate as an actor that hinders the opening of doors to the public here, and thus to establishing a direct connection between the café and the patio. There are doors; however, in contrast to the opposing entrance doors, there is no airlock over here. Again opening the doors, and as some people might not close them, could be a challenge for maintaining a constant museum climate. On this tour we encounter not only the past and present settings, but also future projects. Working-with the building is a constant re-thinking of possibilities for new ways of spacing. How could they add this link or connection to the building and create new movements, new trajectories, and experiences for people and objects? In the process of re-thinking, already established actors like Historic England are present: 'In terms of listing I think we could manage that and just take out a single panel which could always be replaced anyway.'<sup>23</sup> Winner imagines creating a link via the thick skin in the back of the café not only for the purpose of the café but also to give direct access for visitors to the growing Sculpture Park next to the building and on campus. Obviously not only Historic England upholds the material setting and complicates a re-arranging of elements and introduction of new networks. With our first two stops we approached areas that seem to be in a constant mode of change—rhythmically hosting different pieces of art, changing their material arrangements, and the flow of their visitors. And furthermore, areas which seems to be recently at the heart of a strategic re-thinking with the building, a course of testing new ways of working with the building and negotiations about what the building can do in terms of spacing. Entering the Living Area we confront a different situation.

---

22 Winner, walking interview.

23 Ibid.



**Fig. 4.6:**  
Third stop and actors.

#### 4.4.2 In Its »Script« Anti-Museum

Winner mentions that they have some issues with the screens. Amongst others they are not high enough for some of their paintings. But because of what these screens do in relation to the building and the objects, they are ‘keen to retain’ them. ‘You would not expect it until you come here.’ In other words, you have to experience it. Winner explains in a later interview that the Sainsburys did not want to create a museum. He says, ‘they were anti-museum’,<sup>24</sup> less in an understanding of a political act than with the will to democratise art, to make it part of everyday experience. It was for this reason that they were ‘breaking down barriers, breaking down walls’, Winner says.<sup>25</sup> Creating a museum as a social space, having coffee next to the gallery was unusual back then, however, it is common today. But it is not only about the symbolic proximity of the areas. It is also about the process of experiencing the art itself.<sup>26</sup> Winner emphasises that the height of the walls is important to how ‘the building operates’, how we perceive the building, and how we interact with the objects (in an intimate setting). Thus, the walls are considered an important actor in experience.

24 Winner, in-depth interview 2.

25 Ibid.

26 Compare the museum as ‘classifying machines’ discussed by Hetherington (1997).

One of the great pleasures of art is being able if it is an object to handle it, to be able to alter the angle at which you look at it, in the case of a picture to look at it in all lights and in all moods. (Robert Sainsbury in Downing 1979, 04:11-04:27)

This is not just a historical quote from one of the founders in the documentary *Sainsbury Centre for Visual Arts: The Gift*, but also a vision that was *inscribed* into the design of the building.<sup>27</sup> And more specifically into the Living Area which is supposed to accomplish this vision still today. People should be able to walk around the objects, approach them in an intimate, unobstructed way, and interact with them in changing lights and moods—all this was part of the design brief (even if it was just an unofficial brief).<sup>28</sup> Hence, there is a script for how spacing should take place embedded in the material setting of the Living Area not only back then, but also still today. '[T]his display has more or less stayed the same since 1978, [...] it's considered a historic display. There are objects that get loaned out or need rest, often the works on paper change, but the majority, the more robust sculptural works, stay pretty much in the same place.'<sup>29</sup> Thus, there is a wish to make certain courses of action durable through time. The heights of the wall are part of that script. Approaching the Living Area and the zigzag walls thus crosses different times. 'They [the Sainsburys] wanted things to be visible' says Steven Hooper,<sup>30</sup> director of the Sainsbury Research Unit and editor of the catalogue of the *Robert and Lisa Sainsbury Collection* (Hooper 1997). It is about the direct relationship with the artworks. The designers developed a setting, a proposal, which incorporates this brief.

The building really was a huge frame, and so what it had to create [was] lots of different types of frames at different scales, to relate the objects in the space, and people moving through the space. One of the biggest factors that shaped the design of the installation was creating a series of layers or frames to bring [...] someone's attention to a very small object, the size of your finger or smaller, which really was a manipulation of

---

27 The 'script' or 'scenario' as coined and elaborated by Madeleine Akrich (1992) is the result 'of the work of innovators' (in our case architects and designer) who *inscribe* a 'vision of (or prediction about) the world in the technical content of the new object' (ibid, 208).

28 For the museum part, Foster Associates did not become an official design brief but only two guidelines from the Sainsburys: 'We did *not* want a monument to ourselves nor to him, and we did want a positive statement.' (Robert Sainsbury after Ryczynski, 106; original emphasis)

29 Croose Myhill, Nell (Education Officer, SCVA). In-depth interview by Sabine Hansmann. Norwich, 3 November 2016.

30 Hooper, Steven (Director and Professor of Visual Arts, SRU) In-depth interview by Sabine Hansmann and Maria Lisenko. Norwich, 1 November, 2016.

layers and frames. And lighting, to get people to be able to relate and enjoy objects at that scale in that type of space.<sup>31</sup>

The lighting and museum designer George Sexton tells with a view to his time during the installation of the exhibition, and lists material and immaterial devices, which ‘scale the space down and invite you into the space.’<sup>32</sup> Clearly, he refers in this quote to a ‘container space’ that *contains* people who move *through* the space, but this is not our present focus. All these material and immaterial devices, the mezzanines, the high and low partitions, the colours, the materials and textures, the types of cases, the grouping of the objects versus singular objects, and the lighting that are mentioned by Sexton—all do the work of scaling down. At the outset, with regard to the monospace, the building is described as the largest of frames, but in the next moment, this idea dissolves into other elements, materials, colours and textures by Sexton—all individual actors that do something together, allowing people ‘to relate and enjoy objects’. The building in the meantime has disappeared.

There is little text, and lots of natural light that penetrates the façades, free-standing screens and small display cabinets allow for meandering from object to object without curatorial guidance or art historical classifications. And this setting is still more or less the same. ‘The Living Area display, which has gone through about four or five changes, is not all that different; it’s a bit denser than it was almost 40 years ago,’ Hooper explains.<sup>33</sup>

The ethos is that it should remain inspirational. People can come in, and they just see forms and shapes; just human creativity. And then, if you want to learn, you can go to the catalogue, you can go online or go into the library, and it’s like a separate thing. The Sainsbury Centre staff and,

---

31 George Sexton in: Sexton, III, George S., and Joe Geitner (Sexton Associates, lighting and museum design). In-depth interview by Sabine Hansmann. Washington/Norwich/Berlin, 18 September 2017.

32 Ibid. Sexton was initially approached to focus on the exhibition lights he later was commissioned as an acting keeper (acting director) for 18 months while the Sainsbury Centre was put into operation during 1977–78. He was entrusted with the task of organising and installing the exhibition. Opening his own lighting and museum design firm, George Sexton Associates in 1980, Sexton and his team stayed in close contact with the Sainsbury Centre. Having been under contract for the exhibition design for many years, today Sexton Associates still has a contract to maintain the lighting systems and they are still occasionally involved with exhibitions.

33 Hooper, in-depth interview.

certainly us, are happy that that remains a priority. The priority is about the inspiration of human creativity.<sup>34</sup>

Thus the idea of 'being anti-museum' was inscribed purposefully into the setup by the Sainsburys together with Foster Associates and Sexton and all other actors involved in the design process. The anti-museum does not communicate contextual information about the objects of art. There are only small labels giving a minimum of information. Furthermore the building does not provide traditional walls to put anything on, there are louvres along the interior skin preventing the use of the inner façade as hanging area—they cannot be painted, and nothing can be attached to them. There is the floor, a grey striped carpet (not a very flexible, robust material and rather unusual today in a museum context) that stages the artworks on screens and small freestanding display cabinets. This setting indeed mobilises the visitors to move around and view the works of art from different angles (see Chapter 5). However, this setting is challenging for a museum, for staging different shows, as Greenhalgh emphasised. It is also difficult to possibly change climatic conditions. Thus, there is a contradiction between keeping and nourishing the existing Living Area and with it the legacy of the Sainsburys and of moving on and facing today's institutional obligations.

#### 4.4.3 Stability: The Work of Many

Claudia Milburn, who is a curator at the Sainsbury Centre, explains that there indeed were ideas to change the Living Area as well:

When Paul [Greenhalgh] started he had some plans to change that space and then soon realised that actually that has to be a stable space; it has to remain in keeping with the original ethos of the building and how the Sainsburys wanted it as the extension of their living room. How those screens are devised can't really be moved much, so there's a kind of stability to that area.<sup>35</sup>

If the Living Area is not connected to the practice of flexibility but rather that of stability—who or what keeps it stable? Greenhalgh emphasised that it is important to keep the 'integrity' of the monospace and hints at the people who are involved: 'It occurred to us that we should put the big exhibitions downstairs. When Norman heard the idea, he liked it. David Sainsbury liked the idea. Because

---

34 Ibid.

35 Milburn, Claudia (Curator, SCVA). In-depth interview by Sabine Hansmann and Maria Lisenko. Norwich, 2 November 2016.

it means the upper building is exactly how Robert Sainsbury and Norman and Lisa Sainsbury imagined it would be.<sup>36</sup> The testimony that the Living Area still is ‘the heart of the identity’ of the Centre,<sup>37</sup> seems to be of great consensus within the Sainsbury Centre itself. We touched on the understanding of the building as ‘the best object’ in the collection earlier, which elevates the building to a work of art (Chapter 3.2). This gained support when the building became listed in 2012. As it is common for artworks to be maintained in as constant a condition as possible (Guggenheim 2009), it is tempting to give a simple causal explanation: Because it is a piece of art, it is important, it stays! However, just like flexibility is the work of many, there must be a gathering of actors around the Living Area that keeps it stable. As far as the Sainsburys and Foster are concerned, the Sainsbury family is still particularly financially involved. The son of Robert and Lisa Sainsbury, David Sainsbury, funds the Sainsbury Centre with his Gatsby Charitable Foundation on a biannual basis. Foster in turn still holds responsibilities in questions of design and as an architect plays an unusual role in the life of the building, which is already 40 years old. Winner exemplifies what this commitment includes:

It was his [Foster’s] first public building, as he has credited it as one of his most important buildings, if not, the most important. So, he’s very protective of it, and we still have a direct relationship with him, and nothing happens in the building without his practice being involved, [...] Not so much the exhibitions. The exhibition design and build are very much in our hands. That changes regularly, obviously, but with the permanent display, yes. So that would be the screen system, that zigzag screen system, they were responsible for that, and if there was any adjustment made to that, that would be done in collaboration with them. The permanent collection areas look like that, and that’s the Foster aesthetic.<sup>38</sup>

Winner continues to explain that this does not include the temporary exhibition areas: ‘that’s understood, that’s a temporary build, and that can change.’<sup>39</sup> Networks are apparently determined and formed here on the basis of the permanence of a material arrangement. Areas that are subject to regular change have a different network of actors than those that are permanent, and it seems that Foster + Partners and the Sainsburys isolate the Living Area in a sense to exclude it from

---

36 Greenhalgh, in-depth interview.

37 Winner, walking interview.

38 Winner, in-depth interview 1.

39 Ibid.



building new unwanted and potentially permanent networks.<sup>40</sup> However, what is the Living Area's network? Where can we see the work that is necessary to keep it in place and how is it physically stabilised? The material arrangement provides for certain stability, but constant care is nevertheless necessary. Thus, there are changes, which are compulsory to keep the stability. Material ages and is replaced. This is a work of maintenance that needs to be done with every building, and especially any interior under heavy public use. In the case of the Living Area, it was replaced with continuity in its brief as we have learned. In addition to this kind of exchange of for example technical equipment, carpet, panels and furniture at extended intervals of time, as done in the last major refurbishment in 2004–06 (see Chapter 3), there is also a continual daily process of maintenance that allows the Living Area to do its work of constantly presenting art. Here we enter yearly, monthly and daily rhythms and networks of actors of different material qualities that come together and do the work of caring for and making sure things stay in place. To keep the material arrangement stable the building is never on its own. This concerns cleaning work from the façade, to prevent, e.g. water accumulation and penetration into the building interior, to the vacuuming of carpet in the exhibition area, which 'represent potential niches for bacterial colonisation' (Camuffo 2001, 127). This also includes regular replacements such as of light bulbs or filters in the air handling plant and furthermore, repairs. This broad field of maintenance work on the building could be a study in its own right.<sup>41</sup> However, as it leads into technical details and in particular into the structural substance of the building and thus away from the question of spacing at the intersection of building and social life, I will only exemplarily highlight two regular activities. These will illustrate how humans depend on the work and ability of the permanent presence of nonhumans in their efforts to ensure a more or less stable and safe environment for the artworks.

Maria Ledinskaya, conservator at the Sainsbury Centre, explains that she and an assistant check at least once every three months on an extensive tour the whole building to control any infestation of vermin. They do not actively search for insects themselves but control their helpers.

---

40 See Michael Guggenheim on the tool of physical and organisational isolation to control and hinder the creation of new networks. For artworks this may involve locating them in museums, while for buildings the declaration as monument restricts the number of possible new networks likewise, as Guggenheim points out (2009, particularly 44–45). The Sainsbury Centre being listed since 2012 can be seen as isolated in this sense, yet, regarding the Living Area the isolation seem to be particularly explicit.

41 An unpublished study by Ledinskaya comprehensively recorded and evaluates the structural substance of the building and rates the need for action for different types of maintenance works (2015).

I have these sticky traps for insects that are spread out strategically throughout all the downstairs areas and the upstairs areas. We do the walk and we check the sticky pest traps, looking for things like silverfish or carpet beetle, things that are of potential danger to collections. So, I record all this, and we monitor activity, seeing if any insect populations spike up and why that is.<sup>42</sup>

These sticky traps allow Ledinskaya to be absent and only to control every few months the activities and populations of the smallest inhabitants of the Sainsbury Centre to make sure that there are no species endangering the art. The sticky traps replace her day and night. There are a lot of objects like the sticky pest traps that support the building in its ability to house art, to keep it free of insects, to provide the right level of humidity, or light (as it will be our focus with Chapter 6). Many of them are invisible, hidden in corners or for example under the tray in the cases like the silica gel that stabilises the environment by passive means. Ledinskaya explains that there are different ways to control the environment. However, she found that ‘with most of the cases upstairs it’s not actually necessary, just having the physical walls over the case is enough for the atmosphere to remain stable.’<sup>43</sup> The building does not provide humidity control but the cases take over this task (see also Chapter 3.1.3). Thus, there are ingredients added to foster and stabilise the building’s ability to present art. However, the cases do not only provide for stable humidity levels for the artworks they also mediate the interaction between artworks and visitors. There are rules to prevent accidental damages, which the guides commonly explain during tours: ‘For little ones, it’s no running, no shouting, no touching.’<sup>44</sup> For older children, it is ‘being careful that none of their actions threatens the artwork in any way, so not to touch or poke or prod, or take food and drink into the galleries that might get spilt on the canvases’.<sup>45</sup> Furthermore, there are photography rules, which include the prohibition of flashlight to keep the light exposure for art low. Outside the guided tours and workshops, only a small sign indicates that food is forbidden, hardly visible on the glass barrier (Fig. 4.5). Here it is the task of the gallery assistants to make visitors aware of misconduct. However, the task of looking after the works of art is largely taken over by the material setting. Covers, for the most part, prevent works of art from being touched or exposed to malign influences. Again, they are permanently present and allow the gallery assistants to be out of reach, following the action in the Living Area mainly

---

42 Ledinskaya, Maria (Conservator, SCVA). In-depth interview 1 by Maria Lisenko. 4 November 2016.

43 Ibid.

44 Sturgess, Rebecca (School and Outreach Coordinator, SCVA). In-depth interview by Sabine Hansmann. Norwich, 11 August 2017.

45 Ibid.

via camera monitoring. This is another way of sharing agency between actors in spacing. The cover is not simply a transparent hood but conveys the will of the designers and founders, who impressed their wish to create visibility but prevent touching into the design of the cases. We can call this following Latour ‘delegation’ (1992).<sup>46</sup> The intention of interdicting physical contact is shifted from humans to nonhumans who then carry out this task permanently. In this, they have a stabilising effect on the Living Area. Once again, we approach many layers of time and space in these objects. They ‘prescribe’ the courses of action of visitors today—even years after their inscription at a different place in the process of design.<sup>47</sup> This is how spacing in its complex entanglement in different times and space, different humans and nonhumans needs to be unravelled. A stable material setting is not simply stable—there is a constant work towards keeping the material settings stable—and in its stability, it is never passive. Furthermore, this stability is relative. The Living Area is still more or less the same but this does not mean there is no movement as David Rees points out:

Can you see that white painting over there, a Frank Auerbach painting? That was in the Giacometti exhibition, there was a Morandi there, the Morandi has now moved around the other side of the wall. Also, Giacometti’s *Standing Woman* was removed altogether and has been put back in a different place. For years she stayed in exactly the same place down the end there, but she’s now been moved to somewhere different; there are numerous examples of that because we took quite a lot of artworks out of here for the Giacometti show. They go back but then we tend to replace them with something else and you end up with this knock-on effect [...].<sup>48</sup>

There is movement that takes place, the circulating of art objects. Some of which happens when staging for example a Giacometti show (which happens periodically and the last time 23 April–29 August 2016). Then artworks from Giacometti disappear from the Living Area and move for example downstairs into the new Exhibition Suite. Other objects like the Bacons are frequently requested and leave the building to visit other institutions. Furthermore, there are objects, which are particularly sensitive to light and therefore need to travel downstairs to take a rest in the dark (see Chapter 6)—a movement that is necessary to ensure object stability in

---

46 Delegation is the act of inscribing the competence and responsibility of people into nonhumans with the aim that these can prescribe permanently and potentially more reliable human behaviour (also see next footnote for prescription).

47 Prescription is (after Akrich 1992; Latour 1992) the delegation of behaviour by nonhumans to humans. The prescription implies how to use a machine, a tool, an object etc.

48 Rees, in-depth interview.

the long term. Supported by many tools and instruments, it is the collective work of registrar, conservator, curator, and technical team to decide on the appropriate care and necessary movements. 'It constantly changes, it appears never to move on but it's constantly changing. It's constantly morphing into new phases' Rees emphasises, not only regarding the Living Area, but also in terms of the whole building.<sup>49</sup> Many of these little or minor movements are only visible to the expert's eye. They stay hidden from the sightseer who tends to take the building in as a passive and stable object, while working-with the building, this object (automatically) dissolves into many small objects, relationships and situations with their own intensities and speeds.

While these kinds of material movements take place predominantly with continuity, the Living Area nevertheless exists within a contested space.

In the beginning, when this place was built, it was about housing the Sainsbury Collection, and in the years since then, it's become a lot more outward-facing with the realisation that you need to earn money, so you need to get the people in to see the works and get schools in and encourage education. So, that's developed, and we've had to change with it; we have changed the way we have worked, because it's important to get visitors in.<sup>50</sup>

There is a script of being an anti-museum embedded in the material arrangements, which in the case of the Living Area has gone through several changes while staying more or less the same. Yet today there is a need to encourage education, to get visitors in and to earn money and this changed the way Winner, and his colleagues work with the building and the Living Area.<sup>51</sup> Once in the world scripts are not simply extracted but negotiated. There is always the possibility of changing the script embedded in the process of 'de-description'.<sup>52</sup> At the very end of our tour Winner touches one more time on this issue. I had asked about the education programme and, in response, Winner points out that there are all of these elements of setup that are trying to go against museum practice, if however only slightly. That they should be mindful of what their benefactors had in mind, but are also a public institution and thus have an obligation to communicate the art to their

---

49 Ibid.

50 Hoxley-Carr, Rachel (Executive Officer, SCVA). In-depth interview by Maria Lisenko. Norwich, 4 November 2016.

51 This is a general trend that has been observed for some time in the field of museum studies (DiMaggio 1996).

52 Referring to Akrich (1992) the process of *de-description* of the script lends itself to 'inventory and analysis [...] mechanisms of adjustment (or failure to adjust) between the user, as imagined by the designer, and the real user' (209).

visitors.<sup>53</sup> While Robert Sainsbury emphasised the immediate encounter with art today, a vivid practice of communicating and educating lies like an ephemeral veil over the Living Area. Therefore, new actors have grouped around the Living Area, providing different possibilities of experiencing the art and thus introduced new modes of spacing in this area, however, without changing its material setting.

#### 4.4.4 Heterogeneity in Practice

Communicating art is a broad way of working with the building. It is about building up access, sharing knowledge, engaging with people about and with art. Let us focus for a moment on meeting people who are engaged in the activity of education and communication of art at the Sainsbury Centre and learn about their relation *to* and practice *with* the building, and thus about different modes of spacing. A group of about 60 volunteer guides offers tours: advanced-booked group tours and daily public tours. I interviewed two volunteer guides; both welcome groups twice a month, both would like to remain anonymous. I, therefore, call them Guide 1 and Guide 2.

When Guide 2 starts with a tour, she likes to begin at the top of the spiral staircase or come in on the glass walkway. Here, visitors ‘would get an impression of the building, they can see it from a high vantage point, get a real sense of the space. Then we go downstairs and I stand in front of the heads of the Sainsburys’.<sup>54</sup> Every guide has his or her own approach. However, the tours I joined and the guides I interviewed start off with the story of the Sainsburys. In the following, they tell the story of Norman Foster’s involvement introducing next what is considered the most important elements of the building before they dive into the Living Area most likely approaching first the *Baby Asleep* from Jacob Epstein, one of the first acquisitions from Robert Sainsbury. Here they begin by drawing attention to different pieces, provide information and try more generally to start a conversation about the works of art. This is only an abbreviated description of an ordinary 11am or 2pm public tour. It does not do justice to the many different tours that are tailored to needs of individual groups.<sup>55</sup> However, I would like to draw attention to two aspects: Firstly, the grand narrative and secondly the practice of communicating the art to the visitors. Both bear witness to the specific way of working with the building in the field of tension between respectfully remembering the benefactors (anti-museum) and being-a-museum.

The grand narrative or the story of the Sainsbury Centre is frequently retold: in publications, on the website, during the tours, in my interviews (see also

---

53 Winner, walking interview.

54 Guide 2. In-depth interview by Sabine Hansmann. Norwich, 15 August 2017.

55 For an insight into the education programme at the Sainsbury Centre see Sekules (2015).

Chapter 3). I witness a strong wish to respectfully remember the benefactors at all levels of staff. It is a powerful story, that of the anti-museum and the domestic Living Area, the friendships and sponsorships of the Sainsburys with the artists and later with the young unknown architect who today is one of the most famous in the world. Being-remindful, however, is not only an immaterial practice of retelling a founding history. That said, the retelling is one part, and there are material anchors to it, like the two bronze heads of Lisa and Robert Sainsbury or Epstein's *Baby Asleep* prominently positioned at the beginning of the Living Area. All these anchors allude, remind, and invite the guides to stop the groups here for a moment. Just as the view from the top of the spiral staircase, which gives the impression of a 'panorama', of a perfect intact world in the distance and an idea of a whole, this founding narration creates the feeling of belonging.<sup>56</sup> However, this founding narration is not to be misunderstood as a context in which the people work with the building. Instead, it is an actor that together with many humans and nonhumans works towards stabilising this place. The objects, in that sense, not only provide stability in terms of material durability, but they connect interactions, they remind and bridge different times and spaces and support to keep the tradition of being anti-museum alive.

Communicating the art, however, is a practice, which is complementary or even contradictory, as it adds a layer of knowledge between people and objects—a relation that the Sainsburys wished to be immediate. But is it that simple to say? Let us return to one of the guides and take a closer look.

It's quite hard to move people around space quickly. I don't know if you've ever tried, but you have to allow for people to follow their own interest or get absorbed in something, or maybe a particular object will take more time because there are more questions or just generally more interest. So, you can have an outline, but it might not always go to plan.<sup>57</sup>

Guiding people around is not always easy. At least it does not always go according to plan. Once again, there are several guides or actors who influence the course of the tour. Guiding is an activity *with* the artworks. Some of them stop the visitors, arouse their interest, and absorb them. Thus, guiding is an activity with different intensities and speeds, with events; just like the walking, that we explored earlier (see Chapter 2.2.2). The tour is spaced by the different actors that take part in it—there are the artworks, the visitors, the guide, but also the carpet, the high ceiling, and the sound-absorbing walls that for example do not always make it 'easy to

---

56 See Latour (2005, particularly 183–90) on panoramas, and their ambiguous character between showing *everything* and *nothing*. See Guggenheim (2009) on how objects relate to time and are capable of stabilising memory.

57 Guide 2, in-depth interview.

project your voice to a large group constantly', as Guide 1 points out.<sup>58</sup> The building and the material arrangements take an active part in every tour. And this can even be better understood in the contrast between the ground floor and the basement. The setup of the Living Area supports a smooth way of guiding visitors while the layout of the Exhibition Suite, for example, seems to be more challenging. 'I don't think there's ever a time when we can't move around [...] the Living Area quite comfortably with a group; it's very easy. Maybe in the special exhibition area when it's busy, that's more difficult, partly because of the nature of that long corridor'.<sup>59</sup> Here they have to keep the group on one side to let other visitors pass. The high visibility in the Living Area, 'the fact that you have totally uninterrupted space and you can see where your colleagues are working very easily makes it much easier' and allows for a great deal of 'fluid[ity] with the groups'.<sup>60</sup> This is something supported by the scale and the shape of the building, 'you don't wander from room to room, you wander from space to space'.<sup>61</sup> Wandering from space to space, following the material arrangements, in the Living Area, is not a linear process. Sometimes the works of art take over; sometimes the guide, a guest, or the presence of another group redirects the trajectory. However, they do not wander within space but *with* space. New connections appear, and with a turn around the corner, others fade. Communicating art thus is not necessarily associated with the insertion of a distance in the immediate experience. In some cases, this immediate experience, which contrasts with knowledge-driven communication, is taken as the starting point:

If I am doing a session, it will always start from just letting people explore, feeling at home within the space. So usually I would start somewhere around the Henry Moore *Mother and Child* in the middle, but always give people an opportunity to spend a few minutes doing whatever they want before I then hone in to do particular activities. But the particular activities are usually, take a thing, see where it leads you.<sup>62</sup>

Alexandra Woodall is Head of Learning at the Sainsbury Centre at the time of interview. Her work is not knowledge driven as she emphasises, 'I'm not a curator; I'm not an expert on the context of any of these objects whatsoever. I don't approach objects from needing to know anything about their context. I only know

---

58 Guide 1, In-depth interview by Sabine Hansmann. Norwich, 6 November 2016.

59 Guide 2, in-depth interview.

60 Guide 1, in-depth interview.

61 Ibid.

62 Woodall, Alexandra (Head of Learning, SCVA). In-depth interview by Sabine Hansmann. Norwich, 15 August 2017.

things accidentally, in a way. So, I would always use things as a means of exploring ways of looking and ways of finding out things without needing to know.<sup>63</sup> She explains that the Living Area is ‘perfect for us because it enables us to just open it up to whatever our visitors want.’<sup>64</sup> The absence of text, of interpretation, is essential for this purpose as it allows her to bring the visitors and the ‘things’ directly together without any pre-informed layer of meaning in-between. ‘Take the thing and see where it leads you’, is also the idea of the *object dialogue boxes* by the two artists Karl and Kimberly Foster whom she has worked with a lot. ‘These are beautiful boxes filled with quite surreal objects, and the idea is that visitors, as a facilitated session, take these surreal objects and use them to make a connection between the weird thing in their hand and something in the gallery. But it’s totally led by the visitor who’s holding the thing, or you could argue it’s led by the thing.’<sup>65</sup> The education programme experiments with how people experience the art and the building; experiences which are not guided or under full control of humans but take place with the nonhumans (see also Chapter 5). ‘Lie down in the gallery’ is a little yellow brochure produced by the group of Young Associates at the Sainsbury Centre led by Nell Croose Myhill (Sainsbury Centre Young Associates 2017). It invites one to explore the Gallery differently and contains advice like, “Hide and seek”, “Draw an artwork with both hands (pencil in both hands)”, “Mime an artwork”, “Make a friend for a lonely object”, “Critique an object individually or in a group”, which plays with ways of knowing and looking and tests new modes of engagement with objects—some of them challenge what could be described as ordinary practice in a gallery.

All this is experimenting with spacing. It changes the practices of viewing, perceiving, understanding and moving with the objects. This could well be in the interests of the Sainsburys, but that is not to be judged here. It is more important to emphasise that it is a practice of adjustment in de-scription of the Living Area. The ‘users define quite different roles of their own.’ (Akrich 1992, 208) The action of communicating the art, like the adding of contextual information can be understood as a process of objectification of the art and a distancing of immediate experience;<sup>66</sup> however, it can also guide, leading to experience many different relations, in heterogeneity,<sup>67</sup> as we have seen. Both shift the relation of the different

---

63 Ibid.

64 Ibid.

65 Ibid.

66 See Hetherington (1999) on the changing relation of subject and object in the history of heterogeneity in museum spaces.

67 See Hooper-Greenhill on the museum concept of ‘post-museum’, which is shifting away from the modernist museum, as a place of ‘many voices and many perspectives’ (2000, 152).



actors by adding new actors (knowledge, strange objects, instructions) into the seemingly stable network for action with the Living Area.

Thus, the Living Area can be understood as a stable space in terms of its script and in relation to its materiality. Furthermore, it has a stable network, which functions every day towards the constant re-production of this space. A space largely defined by prescription. Space is nevertheless shifting and changing in relation to the practices that appear with the Living Area in the course of de-scription. Since we witness different practices and new experiences, new spaces in turn are encountered. Spacing is about negotiation with the existing scripts and here differences occur.<sup>68</sup>

As the Living Area in its layout invites individual encounters, we discover a specific situation in which prescription and negotiation co-exist in the sense of continuity in difference. Part of the script is not having a uniformity when it comes to activities, but a diversity of experiences in the loosely scattered field of art works—contrary a linear narration of the modern museum and gallery (Hetherington 1999).

## 4.5 Conclusion: Connectivity in Spacing

‘Taking a walk’ to explore the ordinary world of the Sainsbury Centre turned out to be very different from a static interview conducted at a table. The building, but even more so the many individual elements (the connecting point, the glass case, the connection to the patio, the walls), direct and divert the course of the interview. Thus, the interview was not linear, neither in space nor in time. We approached many different spaces and times guided by Winner and guided by the building, a building that is itself on the move and always changing. Winner stops and is stopped at points that are of concern and he starts to introduce the way that he and his colleagues *work with* the building in specific locations. However, this is not a working with a singular static object but in multiple and various courses of action and then also with multiples objects. Thus, in the interview the building disappears as a Late Modern and High Tech construction. Questions of style

---

<sup>68</sup> Akrich (1992) particularly draws attention to negotiations which are then translated into technological objects prescribing certain roles for future users (which then still can define their own roles). Murdoch (1998) explores further the aspect of negotiation and prescription in connection to space for the field of geography (see also Chapter 4). Speaking of the ‘space of negotiation’ and the ‘space of prescription’, Murdoch highlights that both can ‘emerge from within the same networks’ (ibid. 364).

and age categorisations vanish and practicalities come to the fore. In the walking interview, the attention stays with the thingly world we move in. This world is introduced with biographical details. Winner points to the most recent changes, to specific current challenges, to future projects and options for transformation always in relation to how the Sainsbury team works with a particular area and/or what difference specific elements make. These biographical accounts are different from Rybzcynski's biography (Chapter 3.2.3). Like the interview itself, it is no linear narration: neither in space nor in time. It is not *the* biography of *the* building, but rather a biography in fragments. However, it is not as if the grand narrative of the Sainsbury Centre that is frequently retold in the publications about the building would disappear. The Sainsburys and the founding myth are there to stay. Yet, it turns out that this narrative is not *outside* or *above* the building, but an actor in itself. It guides today's decisions; it gives a starting point to the public tours as we have seen, for example, with the two bronze heads of Lisa and Robert Sainsbury, and thus it directs and changes trajectories. Foster is also here. Not as the big starchitect, however, whom we encounter in the literature, but with regard to his very specific influence on and contribution to specific decision processes today ('a temporary build can change').<sup>69</sup>

Therein lies the very contribution of this type of interview and approach as we leave the big picture, focus on particular spots, and deepen our knowledge on very specific elements and entanglements. We gain a first impression of how people and things are interwoven in practice. With this pragmatic introduction to the material world of the building, we witness what the objects do and how they become. We gain a clear understanding that it is neither a simple functional nor a semiotic interpretative relation that the people and the building share (Kamleithner 2014; Chapter 1). Instead, we gain an idea of their complexity. Slowing down and listening to the team of the Sainsbury Institute, countless relational things emerge, things the team engages with every day, that redirect decision, movements, and trajectories. Thus, we learn how the building and its elements take part in daily life.

The isometric diagrams help to anchor or situate the new knowledge gained and to build a connection to the three-dimensional abstract body we are used to handling in architecture. That said, we encounter a great complexity of temporal and spatial connections that go beyond the visualisation of these drawings. We are no longer in a pre-existing Euclidean space. The space that we approach here is not one of scale but a space of connectivity, of a network in the processual reality of architecture.<sup>70</sup> Turning to spacing we encounter 'connections, short circuits,

---

69 Winner, in-depth interview 1.

70 Tracing connections is essential to Latour's project of *Reassembling the Social* (2005) and ANT more generally. Yaneva then conceptualises buildings as 'a tie amongst others', as 'a specific *connector*' that shapes experiences and practice (2010, 144; original emphasis).

translations, associations, and mediations' (Latour 1997, 183) in the act, thus making the witnessing of how architecture connects possible. This reality 'constantly changes, it appears never to move on but it's constantly changing' and this is most obvious when working with the building.<sup>71</sup>

Space is not what is contained in a building but what is practiced with a building. This becomes particularly evident when approaching the paradigm of flexibility that is traditionally connected to open plan buildings (see Chapter 2.1 and 3.2). Analysing the plan of the Sainsbury Centre and taking the intention and history of the founders and architects into account, we get the idea that the Sainsbury Centre indeed provides a flexible space, is open to (spatial) experiments and change (see Chapter 3). Turning to its lived reality, however, the monospace part of the Sainsbury Centre is not what can be described as a flexible space. As we have learned, the new underground area with the traditional room-based layout is in fact the flexible space. It becomes apparent that flexibility and likewise stability are practices. Space depends on and emerges with practices and these practices are hybrid human-nonhuman. Approaching Winner and his colleagues takes us into details in which we can witness the specific connectivity of humans and nonhumans in practice.

Unlike traditional sociology, which for a long time had banished things from its view of the social (Delitz 2009a), and which still seems to have some difficulties incorporating them into its spatial thinking outside human-centred considerations, ANT permits the acknowledgement that space is made up and composed of a lot of 'stuff'. Materiality here is not viewed as representation or materialisation of the social (see Chapter 1), but as an actor that can shift the course of decision-making (move the temporary exhibition downstairs), of daily practice (take the stairs not the goods lift) and thus shift, redirect or modify reality. This is familiar ground for architects and the basis of creative pragmatic thinking in producing new realities. That said, there is the tendency to treat buildings, if not as artworks (as we face with the Sainsbury Centre), but at least as discrete objects negating or trying to determine to a certain extent the processes that do take place with it (Guggenheim 2009; Till 2013). Acknowledging that buildings—that things—can never determine a certain course of action, as there is always a possibility of acting otherwise in spacing,<sup>72</sup> thus implies shifting the notion of building.

Space is hybrid—the work of many—humans and nonhumans. The building and its elements take part in this work, but the real question is how. Here again ANT is of particular help. It allows us to analyse specific connectivity and provides

---

71 Rees, in-depth interview.

72 Compare the interview with Michel Foucault, *Space, Knowledge, and Power* (Rizzoli Communications 1984) where he describes liberty as practice and relativises the position and power of architects. See also Till (2013) who shows how architecture's determination vanishes in its dependencies.

us with a vocabulary to address the different ways humans and nonhumans share agency. Spacing emerges from within agencies and thus we have to shed light on the way humans and nonhumans co-exist in specific courses of action. The concept of script by Akrich (1992) allows us to acknowledge the presence of architects, patrons and craftsmen who inscribe a vision into the setting. We learn, for example, that the Living Area should permit people to have an intimate experience of the art objects. Hypotheses concerning the panels, the light, the carpet, the cases etc. were inscribed into the material setting and thus stabilized over space and time. Today this script and programme of the setting is enacted in the daily routines of the human and nonhumans involved; it prescribes certain movements or interactions (this we will also explore in more depth with the next chapter). The constant presence and action of nonhuman vigilance—such as the cover over the cases—hinders people from touching the art objects substituting human observation in some cases. Action here is delegated to nonhumans (Akrich and Latour 1992). Additionally, the concept of script allows us to shed light on the creativity or ability of interpretation by people in the process of de-description. Taking for example strange objects with them on a tour creates new spatial experiences as new interactions with the existing setting and works of art occur. Adding temporarily or permanently actors into a network distributes agency differently, creating new spacings and changing experiences.

Approaching the Living Area we confront a great deal of temporal (network) stability or a practice that is consistent and continuous. With Murdoch (1998) we can differentiate here the ‘space of prescription’ and the ‘space of negotiation’. The former tends to give architects the security of being in control. Yet, listening to Winner and colleagues we gained an understanding of the negotiations involved—of the different ways links are established, maintained, or dissolved in shared agencies. Thus, the latter, the space of negotiation or de-description, dissolves this supposed security once again. Both, stability and negotiation come together in the course of spacing.

By shifting our focus from outside, from a contextual approach to the messy real world with its mediating elements we become aware that objects as mediators can act in surprising ways and can only be defined in the process of action. We learn that it is work to stabilise and create a predictable environment. We witnessed how stable climate, a beautiful glass box, how sticky traps and glass covers participate in courses of action, how they shape, facilitate, foster or hinder certain spacings. Equipped with the understanding for the fundamental entanglement of human-nonhuman-interaction in spacing and in particular with this chapter in the process of working-with, let us turn towards the people who are only temporarily engaged with the building. Let us continue to explore how people experience the art and the building. How is the engagement of visitors in spacing different and how are we to approach the experiences of people who are only temporarily present?

## 5

# In Practice II: Visiting

---

What does it mean to experience a monospace? As humans in space, we move according to corridors, walls, and doors; doors which we can open and others, which we cannot. These corridors, walls, and doors guide and limit our experience. In an open space and a monospace in particular, these limitations are different. At first glance, an open space might suggest that everything is possible, but it is not endless, and there are some fixed points and anchors in experience. A building in experience is always different. It is never the same. When we approach people, what are the differences in their experiences, regarding engagement with space, concerning practices, trajectories, and attachments? Turning to experience, we follow a pragmatist understanding of this term (Chapter 2.3). The point here is not to discuss what experience is but to use it as a tool to gain access to specific spacings. Following the ‘process of experience’ we can approach human-nonhuman-interactions while circumventing the idea of subjective or objective experiences and hence of a subjective or objective space.<sup>1</sup>

As we have focused on people who are permanently engaged with the building in the last chapter and learned about their working-with, this chapter is dedicated to people who are just temporarily entangled with the world of building. Both the visitor who stays for a few hours in the building and the curator who is

---

1 Turning to the process of experience, a concept leading back to Whitehead, we can address both *what* and *how* interaction takes place. As John Dewey points out: ‘We begin by noting that “experience” is what James called a double-barrelled word. Like its congeners, life and history, it includes *what* men do and suffer, *what* they strive for, love, believe and endure, and also *how* men act and are acted upon, the ways in which they do and suffer, desire and enjoy, see, believe, imagine—in short, processes of *experiencing*.’ (Dewey 1929, 8; original emphasis) Dewey here refers to William James’ *Essays in Radical Empiricism* in which James opposes the dichotomy of thoughts and things, saying that no dualism of subjectivity and objectivity ‘resides in the experience *per se*.’ And further: ‘In its pure state, or when isolated, there is no self-splitting of it into consciousness and what the consciousness is “of.”’ (James 1912, 23; original emphasis) In the process of experiencing who/what acts and who/what is/are acted upon stays indefinite.

engaged on a daily basis over an (potentially) extended period of time take part in the process of spacing. However, their spatial effect might be of different stability due to how they relate. Since particularly the nonhumans create stability and continuity, the capacity to change them implies a greater spatial efficacy. Yet, we saw that in the course of description new practices and experiences can be negotiated. So what are the mundane experiences of people?

‘Temporary actors’ in the Sainsbury Centre can be amongst others visitors, students, suppliers and temporary workers—people who are in and with the Sainsbury Centre ranging from a few minutes to a few days. We have seen that the way Winner and colleagues share agency with the building is diverse. Yet, how do visitors relate?

This will neither be a general story of visitor experience nor a comparative analysis of experiences in museums.<sup>2</sup> Some of them might be similar to other museums but this is not my point of departure here. Instead of comparing different individual perspectives or viewpoints to the Sainsbury Centre, which would keep us moving around the object leaving its physical reality ‘untouched’, as Mol argues (2002, 12), we turn to the activity in experience. Then again, how can we follow the many small movements and actions, decisions that take place, every day? Ordinary practices that happen and disappear, invisible to the one who did not take part in it. How can we as researchers learn about the uncountable and unobservable possibilities of the state of flux of spacing? Once more we will need to slow down and move into the world of the people in and with the Sainsbury Centre to see the richness of the ordinary—to see how the building is perceived, practiced and experienced. People themselves can tell the best about what the building does with them, what it does to those who temporarily connect. With a view to the walking interview (Chapter 4), which we have now confirmed is particularly useful for exploring the complex and rich world of a building, I chose to ask my interviewees to sketch (see also Chapter 2.5). As the walking interview prevented contextualising overview narratives and was (rather automatically) concerned with the earthly detailed reality of the building, so too I believe will the sketching interview offer an unconventional approach for exploring the lived reality of the building.

In the following, I briefly reintroduce the choice of method before we head off into the Sainsbury Centre and trace different encounters with the building through sketching interviews. For this chapter I furthermore draw upon the in-depth interviews with employees of the Sainsbury Centre, for example those involved with the visitor journey.

---

2 For the history of subjective experience in relation to the development of gallery display see Klonk (2009).

## 5.1 Sketching Experiences

Taking up a research methodology, the mental map interview, which is commonly used by geographers or psychologists to create mental representations to research aspects of spatial orientation or knowledge (Gould and White 1974; Downs and Stea 1977; Sommer and Aitkens 1982), I suggest sketching interviews as a tool to approach specific experiences in a pragmatist manner. Thus in the context of this work, asking visitors and other people who are engaged temporarily with the building to sketch while answering questions should not be misunderstood as a psychological experiment. Instead, it offers a way of learning about their activities and draws attention particularly to the nonhuman influence on them. Thus, it gives access to specific experiences of the people in brief interviews ranging from 10 to 20 minutes in duration. While I conducted these interviews also with people who work permanently at the Sainsbury Centre, this type of interview proved particularly helpful for witnessing activities, which I could not follow in full length (e.g. by shadowing visitors throughout their stay at the Sainsbury Centre). I will argue that the effect is like a joined virtual walk in the building, just like my walk with Winner. Sketching while answering the question of what they did and where they moved once again binds the interviewee to the very situation of interaction and allows the doing with objects to become visible. Thus, this chapter aims at both introducing the diverse spacings in experience and discussing the methodological challenges this implies while introducing the procedure. The interviews presented here were chosen after different activities that became visible. While the grouping of ‘arriving’, ‘exploring’ and ‘returning’ might suggest a linear trajectory in time and space, my focus rather stays with the networks that become visible when exploring spacing.

We start off, first, with Mr and Mrs Smith who just arrived at the building, and still feel disoriented.<sup>3</sup> In their arrival, however, they are not alone but embedded in many networks—networks, which attempt to ease a visitor’s journey. We will see how some of the actors on the Smith’s trajectory towards the building impede an undisturbed arrival and we will witness human fragility when networks fail. Secondly, we explore the Living Area. Previously we gained an idea of the stability of this area (Chapter 4), yet, what does this mean for the processes of experience? What do people do over there? How and where? Which nonhumans do they interact with? Again, how is the experience in the Living Area different from the temporary exhibition area in the underground part of the building? Finally, there are those who return and visit the building more often and who are used to the monospace. We witness how their experience is different regarding engagement with space, in spacing.

---

3 All collected information about visitors were evaluated and used in a pseudonymous form.

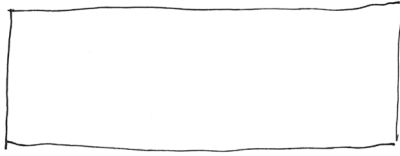
## 5.2 Arriving

On a Sunday morning not long after opening Mr and Mrs Smith who had just arrived in the building a short time earlier, agree on participating in a sketching interview which is concerned with the question of 'how people perceive and use space.' We sit down in the East End Café. My temporary student assistant Maria Lisenko who joined me on this research trip interviews Mrs Smith while I sit down at a separate table with her husband. In the following Maria and I both stick to the same questionnaire; we explain the procedure as such first and ask if audio recording is a problem. It is not, and we start with initial questions, which try to clarify the nature and purpose of Mr and Mrs Smith's visit at the Sainsbury Centre, as well as the frequency and duration of their visit(s) before the actual sketch interview starts. Mr Smith and his wife visit the Sainsbury Centre for the first time. They entered the building and strolled through the East End Gallery. Mrs Smith explains to Maria that they do not plan to stay for long in the building but that the walks outside attracted them as well. Like questions at the conclusion of the interview on their profession, these first questions allow initial answers to be given and to learn about the duration of their engagement. For the actual sketching interview then Mr and Mrs Smith receive plain sheets of paper and pencils and we ask them to speak out loud while drawing their answers to the three questions posed to record their descriptions.

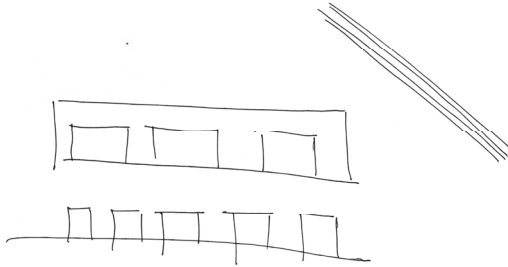
Let us have a look at the answers and sketches of Mr Smith first before turning to Mrs Smith. What does it mean to experience the Sainsbury Centre the first time as Mr and Mrs Smith did? Moreover, how do the drawings support the interview?

After the short introductory conversation about the context of Mr Smith's visit I start the actual sketching part of the interview and read out loud the first question: 'Could you please draw the Sainsbury Centre? In other words: Imagine you are telling a close friend about your visit here. What was/is important to you personally?'  
 'As I am a first-time visitor, and I haven't looked around the exhibition, at the moment, to me, [...] the Sainsbury Centre is just an empty box. We are about to explore to see what is inside it.'

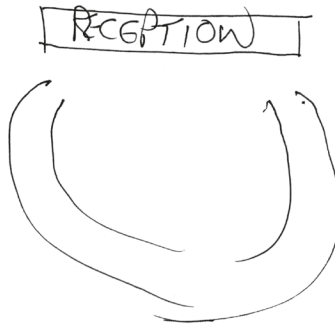




**Fig. 5.1:**  
Sketch 1 by Mr Smith<sup>1</sup>



**Fig. 5.2:**  
Sketch 2 by Mr Smith



**Fig. 5.3:**  
Sketch 3 by Mr Smith

---

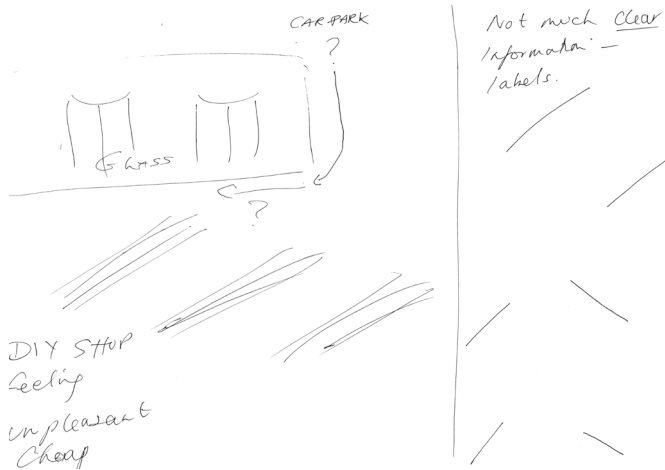
1 Mr Smith/VL2Z. Sketching interview by Sabine Hansmann. Norwich, 6 November 2016. The numbering of the drawings in sketch 1–3 follows the three questions of the sketching interview. Where necessary, reference is made to indicate that one drawing contains the answers to several questions and was extended successively.

Mr Smith does not hesitate but answers right away, and draws an empty rectangle (Fig. 5.1). There is no context to his rectangle and no content in it. I pose the second question, which is the same for all participants: 'Could you please draw the inside of the building?' At the moment the most [...] visual thing is the actual structure itself. The inside is made up of a lot of empty space, but the ceiling is quite striking with the [...] blinds, and at one end there seems to be an interesting gallery, but I am not sure whether it is public or not. So that is something that we need to explore, down at the end of the building.' First, he traces four oblique lines to symbolise the louvers along the ceiling. He then draws the mezzanine with boxes inside and a line with display cases above (Fig. 5.2) and recalls that he and his wife asked for a plan at the reception when arriving but apparently there is no plan and they were encouraged to explore the exhibition in their own way.

I ask him the third and last question of the sketch interview: 'Think about the different ways you move around here. Where did/do you go? And what did/do you do there?' Rethinking his previous movements throughout the building, he explains that he and his wife went to the reception first and thereafter to the circular shop (Fig. 5.3) to get their 'bearings' where to go and then they 'started to explore the actual exhibits' in the East End Gallery. He draws a bar for the reception and a double ring below.

Not all interviews proceed so quickly. Mr Smith's answers are brief and focus on the most characteristic elements: A box from outside, the louvers along the walls and ceiling, the mezzanine, exhibition cases, the reception and the circular shop behind. I do not ask him about all the objects surrounding us but let his speed guide the interview. He does not draw the East End Gallery or any display items or art pieces that frame the shop to the left and right when entering the building, but restricts his drawings to the prominent visual features and instead puts them next to each other rather than in relation to each other and stresses that he needs to explore further.

Mrs Smith's drawings are quite similar, but her narration concentrates on different aspects. Let us leave the interview with Mr Smith for now and listen to Maria and Mrs Smith who sit at the next table.



**Fig. 5.4:**

Sketch 1 by Mrs Smith<sup>4</sup>

Maria reminds Mrs Smith that there is no right and wrong in how to sketch the answers and asks her to draw the Sainsbury Centre. After a short period of reflection, Mrs Smith begins by describing the difficulties they had upon their arrival. Firstly, they could not find the car park, which is undergoing redevelopment at the time of the interview. Also, she continues: 'We were two minutes early, and nothing said when the opening times were so that we could check [...]'. She interrupts herself, 'I haven't drawn anything much yet, but do you want me to draw the actual entrance?' Maria encourages her to do so. 'Yeah? I just remember the two ... lots of glass.' She draws a box and writes the word *glass* in it and adds the doors (Fig. 5.4, upper left area). 'I am writing a lot.' 'That is fine,' Maria encourages her again. Mrs Smith draws arrows accompanied by question marks to symbolise their way towards the building. 'We were not sure which doors took us through, [...] we did not understand where we were supposed to go.'

Mrs Smith does not begin her answer with the building, but with their arrival at the building. An arrival marked by uncertainty and the same holds true of her drawing. She seems to be uncomfortable with drawing or at least has difficulties to accompany her narration with drawing simultaneously. While some interviewees become silent and focus on the drawing, take one, two or even three attempts

4 Mrs Smith/LN3F. Sketching interview by Maria Lisenko. Norwich, 3 November 2016.

to hit a particular angle, and only when asked to do so begin to explain what they have put on paper, others have a need to talk or enjoy sharing their experience right away and then hesitate when realising that the white sheet of paper in front of them is still waiting, empty. A direct map creation, asking the participants to draw themselves, holds a challenge for many people. 'I am a terrible drawer [laughing] no sense for proportion.' However, even if the participants are experienced draftsman this does not necessarily say something about the quality of the drawing, and above all, it does not say anything about the overall quality of the interview, which is characterised by a combination of sketching, including symbols and written words and oral explanations. Drawing and oral interview complement each other. It is part of this method that the sketches are simplifications; they are neither accurate nor complete.

Mrs Smith uses question marks and arrows to symbolise their path towards the Sainsbury Centre and continues when answering the second question to describe the inside of the building.

'[L]ots of space and walls,' which she symbolises with some rapid strokes on the paper and adds that there is 'not much clear information' (Fig. 5.4, right half). 'It is very educational because you really have to find out what you want to find out, so actually you are looking at stuff you really don't want to see. [...] I think it is again that people think it's a wonderful concept, well, they know what it is about but somebody walking in doesn't. Actually, we find it quite difficult because they are trying to step away from the traditional museum, trying to step away from the gallery, I can see that, but in that respect, it is not very helpful for somebody who doesn't know what they are displaying.' Also, this aspect of not belonging to the group of knowledgeable people comes with a feeling of unease for Mrs Smith: 'I found I've got a bit of acrophobia, this ceiling makes my legs go because I am very bad with heights. I am not acrophobic outside but looking up the building makes me quite dizzy, so I don't particularly like the interior. [...] I found it quite daunting, I don't really like the industrial ceiling.' She draws groups of oblique lines underneath the sketch of the building and explains that she does not find it very pleasing to the eye (Fig. 5.4, lower left area). She adds keywords, 'DIY shop feeling—unpleasant—cheap.' Once she stops and laughs out loud, 'I hope the rest aren't like me' and adds, 'I am so critical.'

Mrs Smith is critical, while Mr Smith is not. Clearly, both Mr and Mrs Smith show similarities in their drawings: The box, the ceiling with the louvers, the exhibition displays (by him in a view, by her in a plan). While Mr and Mrs Smith draw similar elements, their experience of arriving in the building does not seem to be a shared

experience. At least they focus on very different moments of experience in their narrations. Does this not show us that experience is always very personal—very subjective? Is this not proof of the division into a stable and *objective* world of objects and architecture (they draw the same elements) and an active *subjective* world, which is highly individual (their perception differs)? Moreover, does this method not seem to produce precisely the separation that I am aiming to avoid? How can we acknowledge the richness of experience without stepping into the trap of talking about a subjective experience in an objective world? What can these interviews show us beyond personal feelings and perspectives? Where is the building in practice?

### 5.2.1 Facing Practicalities

Now, what are we dealing with here? Let us have a second glance. Indeed, there is a sense or feeling that Mrs Smith has been ‘excluded’; she does not belong to the knowledgeable and she also feels physical discomfort. While she finds it ‘educative’ to be put into a situation to ‘find out what you want to find out’, she does not like the industrial look. On the contrary, her husband sticks to a visual and sober world. He excludes any taste, any opinion from his narration and only points to some visually characteristic elements.

However, there are also events in their narrations and this is the path both Mol (2002, particularly 1–27) and Yaneva (2017, particularly 7–8) suggest pursuing in order to leave ‘perspectivalism’ behind and turn towards practicalities.

When entering the building, the Smiths find the reception desk prominently positioned behind the gallery entrance door. Giving them orientation, they walk to this point. To its left the East End Gallery and its right the Living Area. Here they are encouraged to explore. They do not know yet how to navigate this building. A plan could have helped him understand, to read the layout of the building, Mr Smith suggests. Instead he and his wife are encouraged by the visitor service to explore. At the time of the interview, their experience of the interior is primarily a visual one. Some elements that are easy to understand, the outer shape of the building, the reception, the mezzanine in the back, the field of display cases, occur in their sketches. In the short period they spent at the Centre, their experience is mostly driven by visual perception; thus far, as Mr Smith emphasises since they had no time to explore the building in a physical manner yet. They cannot yet make sense of the whole inner world and we can collect events that potentially happen to somebody not knowing the place: Getting lost on campus; walking through the wrong doors; standing in front of closed doors; not having a map or not having labels that guide you around and tell you where to start and where to stop your walk throughout the gallery. These are practicalities. Practicalities a person who enters the Sainsbury Centre for the first time might be more likely to face than a knowledgeable or a permanent actor. Mrs Smith herself points out that she has not been provided with sufficient knowledge on her arrival for her visit in order

to have her experience mediated appropriately, which may indeed be essential for making it run more smoothly. Thus, there are actors missing to form a successful network of arrival—an arrival without gaps—that left her in frustration. With spacing things happen to people.

Turning to mundane spacings we witness how individual and nuanced humans engage with the world of the Sainsbury Centre. We learn that things do not always run smoothly and that gaps in networks can re-direct courses of action (walk to the second door) or leave humans in frustration (and potentially not have them return). Clearly the Smiths are not in control on their arrival, many humans and nonhumans mediate their experience.

Furthermore, we can witness the doing of the monospace. While Mrs Smith expresses her feeling of discomfort Mr Smith refers again and again to the need to explore first. The aspect of disorientation when visiting the Sainsbury Centre for the first time is an aspect that Claudia Milburn, who works as Curator Head at the Sainsbury Centre and has worked in various capacities earlier, addresses:

When I was at the reception, I used to talk to visitors coming in, because they were often daunted by the big space and the fact that the Sainsbury Centre is quite unique in terms of the layout, with it all being under one area, and there being no particular walkthrough.<sup>5</sup>

The monospace, as simple and formally reduced and visually easy to grasp, is nevertheless not necessarily easy to engage with. The absence of corridors, of walls and labels in the Living Area, can pose challenges to people. Milburn would explain that this ‘is part of the building, and that’s how Sainsbury’s wanted it as their Living Area.’<sup>6</sup> What Mrs Smith describes as a ‘step[ping] away from the traditional museum’ as ‘not very helpful for somebody who doesn’t know what they are displaying,’<sup>7</sup> is driven by the Sainsbury’s wish that the collection should not be isolated but be part of everyday life (Rybczynski 2011, 93); a wish that is still actively enacted through the layout and objects of the Living Area (see Chapter 4.4). The loose grouping of the art pieces according to cultural regions, in absence of a defined trajectory, with European art of the 19th and 20th century non-hierarchically dispersed throughout and seating areas and study tables, all work towards a casual and relaxed experience and offer ‘a sense of intimate engagement with the objects’ (Rybczynski 2011, 137). To do so people have to move into the field and let the objects guide them around, as we will explore momentarily. But let us first re-trace the network of arrival to understand how gaps can occur.

---

5 Milburn, in-depth interview.

6 Ibid.

7 Mrs Smith, sketching interview.

### 5.2.2 Networks of Arrival

Getting lost. Walking to the wrong doors. Facing closed doors. These all are happenings or events that connect the Smiths to many actors. Arriving at the Sainsbury Centre is to arrive and be embedded in many networks. Yet, the term embedded *in* can be misleading. It suggests that they are embedded ‘inside’ some context.<sup>8</sup> This implies a third dimension that might lead to the idea that something local, the arrival at the Sainsbury Centre is ‘inside’ something more global, the campus, the city. That would take us out of spacing back into Euclidean space. Let us instead travel along the network, and trace actors in the process of arriving at the Centre.

Indeed, Mrs Smith’s disenchantment about their arrival does not seem to be unusual. ‘[O]ften people cannot find the university or [...] even if they get to campus, they are quite disoriented by the physical layout of the campus, they sometimes get a bit confused. [...] And if they got here and can’t find parking, that’s another big frustration which they tend to meet,’ Rosie Evans, Visitor Service and Retail Manager at the Sainsbury Centre, explains.<sup>9</sup> For creating a predictable and thus stabilised and smooth journey for (especially first time) visitors, there thus seem some actors missing. In November 2016 shortly after the interview with Mr and Mrs Smith a new parking place right in front of the main visitor entrance was opened. ‘[U]ntil 8 November, we didn’t even have a fully formed customer offer [...] customers won’t come here because they can’t park. And elderly people, 50% of our demographic is over 55, they’re not going to walk a long distance.’<sup>10</sup> Penelope Lucas, Head of Marketing and Communications whose primary task it is to promote the Centre and the exhibitions, explains. A satisfied customer encounter thus also includes a smooth arrival that does not ask visitors to walk long distances. If a visitor arrives by car from 8 November 2016 on there is a parking lot that allows ready access to buildings with easily coverable distances. That said, whatever stabilises the network and fills a gap creates new disorders, new hurdles. As there is no barrier at the entrance to the car park, a parking ticket system has been introduced to restrict the group of users to the visitors of the Centre, as parking is free of charge, unlike in the university car parks. That requires people first to park their car, walk into the Centre, ask at the reception for a permit, walk back into the parking lot and lay the permit out visibly in the windshield of the car before they can start their actual visit. As Evans stated in her in-depth interview, ‘getting people through the door

---

8 See Latour (2005, 173–190) on how to avoid jumping between different frameworks or contexts, and to trace the connections ‘through which a local site is *made to do something*’ (173; original emphasis).

9 Evans, Rosie. In-depth interview 2 by Sabine Hansmann. Norwich, 10 August 2017.

10 Lucas, Penelope (Head of Marketing and Communications, SCVA). In-depth interview by Sabine Hansmann. Norwich, 17 May 2017.

is quite a complex process and the one-way system and where they can park, going back with their permits certainly does not help the situation.<sup>11</sup> Disorientation and confusion is a result of a complicated course of action mediated by many nonhumans: The physical layout of the campus; the network of the road traffic regulations with their signs telling people not to turn around on the one-way street once entered; signs indicating the direction to the Sainsbury Centre; street bumps forcing one to slow down;<sup>12</sup> a roundabout with only one exit indicating the direction towards the Centre; the network of the parking lot and the building with its two similar entrances, and the parking permit—amongst many others. The streets, the walkways, the parking lot and the doors they enable and direct, stop and filter flows of humans and nonhumans. They do not always work smoothly together and can leave a person arriving for the first time in disorientation. This can have the consequence of getting lost on campus or taking a course of action that leads one to walk through the wrong door. When we turn to spacing it is not about traveling in space to the Sainsbury Centre. Rather what we are concerned with instead is witnessing the nonhumans who allow and hinder, or facilitate the trajectory when arriving at the Centre.

However, the complicated process of bringing people in starts earlier. The Sainsbury Centre is at the edge, at the very end of the campus of UEA, which lies at the West of Norwich in the North-East of England. ‘We have this interesting issue of being in a field outside of a small city.’<sup>13</sup> Bringing temporary visitors through the door to visit the exhibitions requires a joint effort. There is marketing, for example, ‘a railway poster in Peterborough, digital screens at Cambridge Park & Ride, train cards in trains between here and Liverpool Street London.’<sup>14</sup> The public and private transport system, the station is ‘2 or 3 miles from here’<sup>15</sup> is also involved, as is the content of the show: ‘in autumn we’ll have stuff for the royal connection.’<sup>16</sup> Admission fees are also something to consider, ‘we’re free [the permanent collection], and to see the exhibition is £12.’<sup>17</sup> The Sainsbury Centre is connected with all these networks; it is a node in the network of the university, in the urban network of Norwich, in the Museum network of England. These networks take part in spacing when the Smiths arrive. Some work better than others in creating a smooth journey, but they all add to the experience. Thus, when arriving a particular course of spacing *with* many networks is implied.

---

11 Evans, in-depth interview.

12 For the example of the street bump and the moral dimension that has been delegated to this mediator, see Latour (1994, 38–41).

13 Greenhalgh, in-depth interview.

14 Lucas, in-depth interview.

15 Ibid.

16 Ibid.

17 Greenhalgh, in-depth interview.



## 5.3

### Exploring

People who visit for the first time are a minority group at the Sainsbury Centre.<sup>18</sup> Accordingly, most people whom I met in the building had been there previously. I did not follow the Smiths or interview them again in the afternoon when leaving. It would have been an option to shadow people on their trajectories throughout the building. I did not do this kind of visitor research. My insights are based on my own experiences as visitor; furthermore I have joined the team at the reception and have done interviews with experts about the people temporarily visiting. Apart from that, people can still tell the best about their experiences with the world of the Sainsbury Centre. There are multiple experiences, and they allow us to witness spacing. Experiences are never the same, but similar events are more likely to happen to the same group of people.

A monospace (including the objects) that gives no clear guidance that does not specify a journey's start and end can be spatially disorienting. Everything looks the same in the first moment, 'you really have to find out what you want to find out.'<sup>19</sup> So how is it to explore the Sainsbury Centre?

Mr Walker visits the Sainsbury Centre for the second time. It is early in the evening when Maria approaches him to take part in the interview. He agrees, and they sit down in the East End Café.

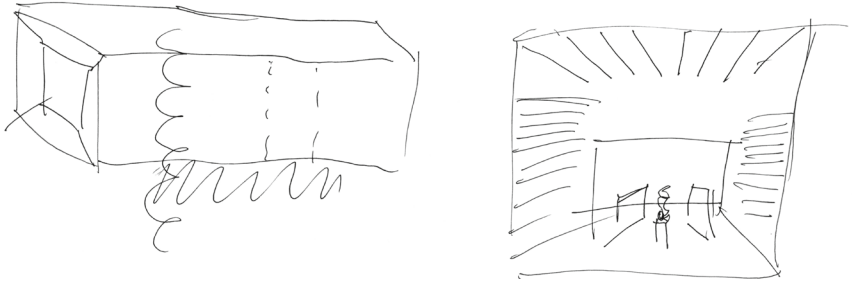
Mr Walker reports that he arrived at noon, met friends for lunch first and then went to see the Fiji exhibition downstairs on his own, which his friends had already seen. For the first question he draws the building from the outside, 'a large elongated box', with ends that are slightly reset. He explains that the wavy line indicates that there is 'more underneath' and that 'the interior space is quite open with a sort of division', which he marks with dashed lines, offices in the middle and the restaurant behind; a curled line stands for 'a couple of spiral staircases inside' (Fig. 5.5, left).

When asked to draw the inside of the building Mr Walker draws the view into a cut box with perspectival shortening to the back. He indicates the louvers along the ceiling and sidewalls and adds 'you have all these dividing panels', 'things on the plinths' and 'nothing on the walls'.

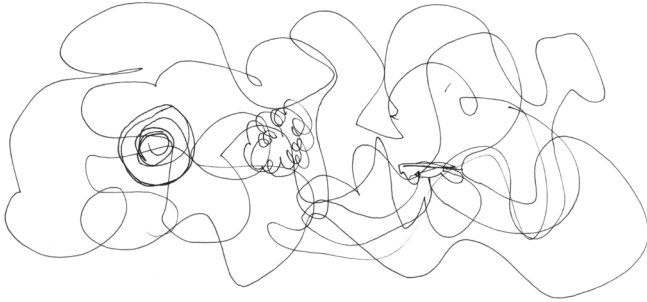
---

18 An internal visitor survey in summer 2016 revealed that only about 12% of the 279 participants of the survey visited the Sainsbury Centre for the first time (R. H. Smith and Lucas 2006).

19 Mrs Smith, sketching interview.



**Fig. 5.5:**  
Sketch 1 and 2 by Mr Walker<sup>20</sup>



**Fig. 5.6:**  
Sketch 3 by Mr Walker

We can observe that Mr Walker has a good understanding of the building, grasping the essential features and being able to identify and locate areas correctly. This does reveal something about his spatial knowledge and ability to spatially orient correctly. However, what does this tell us about his engagement with the building? Where are the events and practicalities? What can we learn from the experience of a visitor who apparently does not feel disoriented anymore? What can we learn about his trajectories? We turn to the third question:

'Ah, that's easy. [...] I just wander. I mean, the exhibition space downstairs is much more kind of guided but up here—I mean there is a little

---

<sup>20</sup> Mr Walker/VG4T. Sketching interview by Maria Lisenko. Norwich, 5 November 2016.

bit of clustering around objects that you like, so, the Hippo might be there, let's walk around the Hippo or the Eduardo Chillida drawing. You keep coming back to certain things—the shop for example—there is the shop, you walk around the shop in a more controlled manner, besides from that it is just meandering.'

Here they are. Here we can witness how the panels and exhibition plinths guide Mr Walker around, how the layout of the permanent exhibition, the clustering into loose cultural regions defines his movement behaviour, his trajectory. His walk is meandering, speeding up and slowing down. A little cluster of small moves around the Hippo (Figure of walking hippopotamus, UEA 306) and a second node in the region of a Chillida drawing let us witness how his walk temporarily intensifies (Fig. 5.6). It is not a linear movement, a guided movement from a to b as this is commonly the case with the underground temporary exhibitions. The permanent exhibition, the Living Area, is a non-hierarchical field. Once overcoming the first threshold of being disoriented, of not knowing, 'you are guided around space by the asymmetric and irregular partitions', Mr Walker emphasises.

Architecture mobilises people differently. While the shop creates a circular bodily movement along its outer edge, in the Living Area people follow the zigzag of the panels, rotate around freestanding plinths, stop, bend down and move closer, they move back and forth, turn around corners—meandering. They are guided around, and the view wanders from close up to the neighbouring, into the depths of the room and back, attracted by the objects.

Mr Walker says he was hoping to see more Eduardo Chillida drawings again, he knows from his last visit that there are quite a number of them in the collection. But there would be only one out at the moment, he notes. The arrangement of objects in the Living Area does not necessarily group works of one artist, especially not the art of the 19th and 20th century. The search for particular works of art can take people into different locations in the Living Area. Passing two or three times over some of the objects, one discovers new things, while maybe not finding what one intended to.

We see that there are different intentions and motivations when visiting the Sainsbury Centre. While the Smiths do not want to stay long since the walks outside also attract them, Mr Walker is searching for works from Chillida. This intentional human world meets the material reality of the Sainsbury Centre. And thus their trajectory and form of interaction is negotiated between their plan and the other actors necessary to realise it. The Smiths have to realise that there is no quick way of knowing what they want to see without exploring the depth of the monospace and Mr Walker might have walked the Living Area several times, without finding more works from Chillida. Spacing happens in these mundane negotiations in which we cannot tell who or what is in control.

### 5.3.1 Walking with the Objects

Another sketch by Séverine a young Erasmus student from France. Her mother visits her for the weekend and sits next to her at the table; sometimes they deliberate over a word. They have been around for about two hours and are finished now.

Séverine quietly draws. ‘I want to represent the little spaces we have in the museum with chairs and tables and you can just sit and observe the art. The Sainsbury Centre is more... you are more free to visit the museum, you can enter, you don’t have to pay, it’s free, and after you just walk around all the sculptures and paintings and if you want to rest you can just have a seat. [...] Lots of space just to think and to observe is what I enjoy here.’

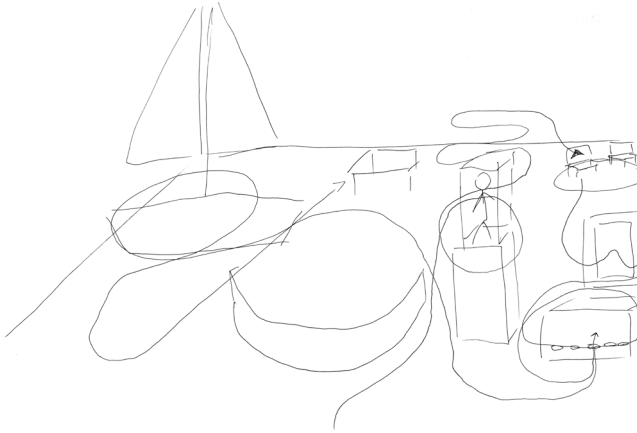
With Séverine we enter an object rich world (Fig. 5.7): We find big free-standing sculptures under glass, tiny sculptures covered jointly, a painting on a panel, the boat in the Fiji exhibition in the East End Gallery,<sup>21</sup> the circular shop (a part of it) in between, the chairs and tables. An arrow points towards the table where the interview takes place, another one toward the seats in the Living Area. We can see her meandering, moving around the objects, changing her direction again and again guided by the art, by free-standing plinths and panels. We learn that ‘not-paying’ takes part in ‘just walking around’ and ‘just sitting and observing the art’. The decomposition into smaller details and ingredients make it possible to see the objects at work, allowing, permitting, guiding and shaping trajectories.

While not all interviewees succeed sketching in such a detailed and rich manner, they may nevertheless be good observers of experiences and pick out a rather symbolic element to then tell in detail about courses of action taken and things discovered. The interview with Ms Abbey’s is such an example:

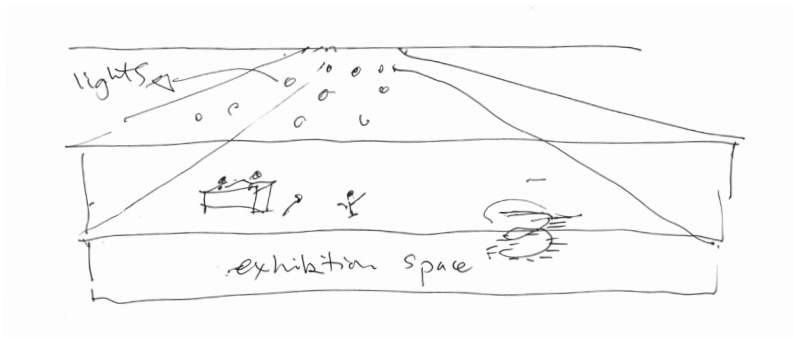
‘I came in the entrance, went straight to the counter and bought my ticket, which is very easy, and then went down to the exhibition I came to see. Down the stairs, I held on to the railing tightly, [...] it is very easy to use actually, spacious staircase, nice rubber floor, so it was kind of not dangerous or anything. And then downstairs I just followed the instructions and went around and looked at beautiful exhibits and I liked it and enjoyed it very much.’

---

21 The exhibition “Fiji: Art & Life in the Pacific” on show from 15 October–12 February 2017 covered both the Exhibition Suite downstairs and the East End Gallery. An eight-metre-long double-hulled Fijian Canoe was one of the major exhibits positioned in the centre of the East End Gallery.



**Fig. 5.7:**  
Sketch 2 and 3 by Séverine<sup>22</sup>



**Fig. 5.8:**  
Sketch 2 by Ms Abbey<sup>23</sup>

22 Séverine/PE6Z. Sketching interview by Maria Lisenko. Norwich, 5 November 2016.

23 Ms Abbey/AA2Z. Sketching interview by Sabine Hansmann. Norwich, 3 November 2016.

The spiral staircase connects upstairs, the main building, with downstairs where the temporary exhibition, in the Exhibition Suite, is located. The older woman, Ms Abbey (Fig. 5.8) explains that because the staircase is spacious and has nice rubber floor, she could walk it safely holding onto the railing. Her straight movement towards the counter is followed by a rotational, downwards screwing motion safely guided by the staircase. Downstairs, she says, she entrusted her movement to the instructions provided. What a detailed observation. While the Living Area upstairs is characterised by a meandering *with* the objects, in the absence of a narrative or explanatory text layer, downstairs a linear narration guides the visitors through the exhibition, texts on the walls and brochures offer in-depth information.

Listening to Mr Walker, to Séverine and Ms Abbey, we get an understanding how they actively engaged physically with the building and we learn that spacing happens with art objects (present and absent), panels, plinth, seating groups and tables, but also with the fact that it is free to enter, has nice rubber flooring and metal railings. The spiral staircase, the rubber floor and the railing not only guide people safely up and down, connecting the two building parts but walking up to its end, it elevates and allows to look out over the galleries.

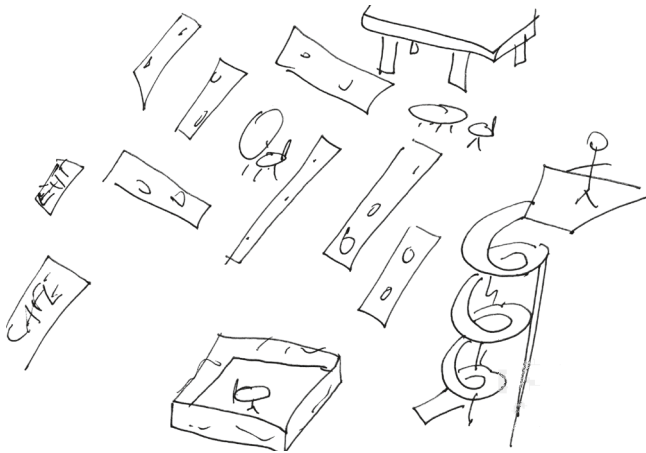
### 5.3.2 Looking Down

A student of Art History and World Art Studies who is in the Centre on a daily basis (and here we leave the group of people visiting only temporarily and move on to the more permanent or regular actors) describes her usual route, down the stairs, into and through the Living Area. She draws the Sainsbury Centre ‘from above’.

‘I spend most of my time in the Social Area and not in the Living Area, so my perception of the Sainsbury Centre is a bit skewed. Most of the time I just cross the Living Area, or I go and sit where the Egyptian art is, [...] which is usually where I sit because the other table tends to be occupied and this one is usually free. So, I usually sit here, and obviously a space I use a lot is these stairs, because these are usually the stairs I take to go in and out of the Sainsbury Centre so in this part of the Sainsbury Centre these are the two most important things to me, in the sense of the ones I use the most. [...] Usually what I do is that I arrive from over there. I just go down the stairs, I will walk past the shop and through the Living Area, and then we have two cases: either I will go to the table ... Oh no, this is really wrong, this is not where the social area is, it is that way, oh yeah, completely wrong. I just realised, the library is that way, and so the social area is this way. Usually what I do is either go here through the artworks to this little table or go directly to them. Either it is case figure 1 or case figure 2 that I usually go to when I go to lectures.’



**Fig. 5.9:**  
Sketch 1–3 by Lisa<sup>24</sup>



**Fig. 5.10:**  
Sketch 2 by Bill<sup>25</sup>

24 Lisa/BE7Z. Sketching interview by Maria Lisenko. Norwich, 2 November 2016.

25 Bill/BS7X. Sketching interview by Maria Lisenko. Norwich, 3 November 2016.

So, I cross the Sainsbury Centre and go to my lectures, which is on the other side of the building or just go into the Social Area to work. This is what I usually do. [Laughing] Do you think you can understand this [Pointing to the drawing]?

Lisa usually enters the building from the bridge, which leads her down the spiral staircase. She then has two routes (**Fig. 5.9**): Either she enters the Living Area and walks to the table with the Egyptian art to sit down or she ‘crosses the Sainsbury Centre’ and walks into the school area. Lisa’s trajectory is purposeful and not explorative, nevertheless we can see that it is shaped in negotiation with other actors. She relates how she chooses this specific table in the Living Area because it happens that the other tables are regularly occupied.

Let us return to the spiral staircase before we take up Lisa’s sketch one more time. Bill, an exchange student from Australia who visits once or twice a week, also points to the entrance via the staircase.

‘When I think of the Sainsbury Centre, I always think of the gallery room, [...] and I would think looking down at it from that spirally staircase where you come through from the walkway. [...] You are going through the trees and then walk in to that little platform on top of the spiral staircase, and you can look out over all the galleries and all the different isles and artworks and things like that and yeah you’ve got this crazy roof above you [...].’

The platform is what facilitates looking out over all galleries. It leads through a large milk glass door out of the building. Here an elevated walkway runs through the top of birch trees and ends on a terrace with further attached walkways linking the Sainsbury Centre with the university buildings from Denys Lasdun. Only a second time visitor would use the bridge, Aaron from the visitor service at the front desk explains. First time visitors would not know if the door is open and it is a long walk to the door over the bridge.

When arriving the Smiths entered the building through the gallery entrance on the ground floor. They approached the reception in front of them, saw the field of art to the left and right of it, followed with their eyes the louvers along the ceiling and the walls into the depth of the building. They could not yet make sense of the whole, however. They did not know for example if the part behind the mezzanine is public and thus they needed, as Mr Smith emphasised, to explore. Exploring is a successive course of action. The etymology of the word ‘explore’ leads back to the classical Latin ‘explōrāre’ (‘to investigate, seek to ascertain or find out’) which consists of *ex* (‘out’) and *plōrāre* (‘to make to flow’) (Oxford English Dictionary 1989b). The world of a building is not experienced at once but successively in



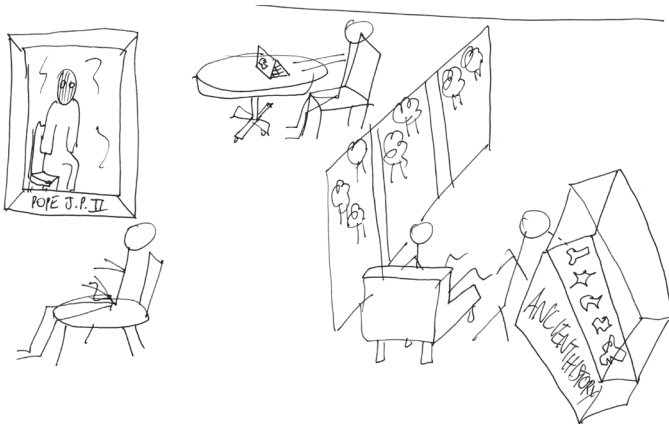
interactions, in the flow. The people are ‘made to explore,’ are ‘made to flow’ by the many actors they interact with.

The platform facilitates a different experience. It removes people from physical interaction with the messy real world down there—it creates distance and overview. It allows for a visual impression of wholeness and creates a static spectator in distinction from a flowing surveyor. However, these experiences are not in opposition. They add to each other. The first potentially binds together what the second has left in fragments and details with different intensities.

Both Lisa and Bill sketch the Centre from above; Lisa, right at the first question and then inserting further details, and Bill, at the second question when explicitly asked to draw the inside of the building. Both their drawings end at the edge of the first mezzanine, a visual barrier that hinders their perception of what lies behind from the point of view standing on the platform. For Lisa also the paper adds to this: ‘Ok I don’t have enough space to draw the rest.’ However, she does not take a second sheet. She spends most of her time in the School Area—a part of the building that could not fit on the sheet of paper anymore—which, as her answer suggests, also does not necessarily belong to ‘The Sainsbury Centre’. She ‘crosses’ the Sainsbury Centre. Obviously, she describes the building based on her activities and role, as a student of the Art History and World Art Studies. This role includes a specific engagement with the building: lectures downstairs and in the seminar room and studying in the school area. So why does she not include these areas in her sketch? Is this only what the paper adds to the interview? Here we enter the world of meaning. And this is how mental map interviews are most commonly treated (May 1992). As drawings, which show representations of cognitive maps, they reveal spatial knowledge and the ability for correct spatial orientation. Some of the drawings manifest, indeed, very poor spatial orientation and Lisa also struggles and blacks out the library in the first spot and relocates it correctly in relation to the Living Area afterwards. Lisa’s drawing and Bill’s drawing are based on their experiences, activities, and engagements with the building. Indeed, we could interpret the maps, analyse what is given prominence and which elements or parts of the building are forgotten and why that may be, we could compare the layout of the building with the sketches and tell about topological aspects, all of which follows the traditional research methodology of mental maps, as used in geography and psychology. However, we can also take the drawings as a tool to complement the oral interview amplifying the description of experiences, showing the many nonhumans taking part in spacing and preventing interviewees from providing broader overview narrations. Hence, they aid in approaching ephemeral material practices and events and thus tracing the spacing.

## 5.4 Returning

Most people visit the Sainsbury Centre several times (R. H. Smith and Lucas 2006). They come back again and again. Let us stay with Bill, the Australian student for a moment before we draw a conclusion. He lives on campus and visits the Centre to sit down and relax regularly. He will take us to four spots within the building: his favourite places.



**Fig. 5.11:**

Sketch 3 by Bill, showing four places he keeps coming back to (from left to right): The painting by Francis Bacon; a round table in the school area; the lounge in front of the glass window in the school area; an exhibit with ancient artefacts in the Living Area.

‘[T]here is a particular artwork in there and it has got this really cool effect where there are lines down the face of the Pope, and it just marks out the eyes or glasses that he is wearing, sort of like a black and red painting, and there is this little seat just in front of that [...] I am not religious, I just like the artwork. So, I like to go in, and I’ll sit there.’ The second spot is located in the school area, ‘on that window there is a series of leather lounges there. On a nice sunny day if it is a bit chilly outside you go, and you can sit there, and you don’t get the breeze, but you just get the warmth of the sun. The autumn kicked it, all the oranges and browns come in from out there, so that is a nice spot to sit in the sun.’ He explains that if he feels lazy, he also sits down in the central school court at the round tables to get some work done. ‘But normally I go there or in the gallery—my two favourite places.’ Also, then there is another spot.

'There is an exhibit in there with lots of interesting, various ancient, Roman or Greek artefacts, utensils, statues [...] I really love ancient history ... I always try to go past that section.'<sup>26</sup>

Bill draws specific objects when asked to 'think about the different ways he moves around'. He says, he goes in and sits there, in front of a painting of the Pope or the windows in the conservatory—especially when it is chilly outside, and the glass only lets in the sun and the colours. There is as well the round table where he sometimes works with his laptop, and then he mentions the showcase with the ancient objects that he always tries to go past because he loves ancient history. The first two he mentioned, the painting and the lounges, however, are *his* 'favourite place', as he emphasises. He keeps coming back to them. He has a personal relationship to these places.

The effect of coming back, of repetition, is one of *attachment* (see Chapter 2.3): the love of the art, the colours, and the ancient artefacts. With his theory of attachment, Hennion (2010) provides a concept to explore or 'attune' actors and the boundaries from within which they act. The world of attachment is one of the amateur. Bill is a student of history and sociology, and he currently deals with topics like consumer behaviour, market relations, crime, gender, race, early modern history and the Vietnam War, none of which is related to his particular attachments at the Sainsbury Centre. His interests are those of an amateur in contrast to a professional world of control (Hennion 2010). It is a specific capacity of the building, and more specifically of the Living Area, that allows for fidelity. Ben is faithful to his 'favourite places', 'normally he goes there'.

Hennion suggests turning to the techniques and performances involved in attachments to unravel how the capacity to act emerges from within boundaries and how they 'make us be', as Latour says (1999a, 22ff.). Bill, however, does not tell in detail about the objects and techniques involved; we cannot witness his rituals and repetitions. Nevertheless, there are many actors that take part in his rituals we have already encountered: The painting he describes is by Francis Bacon, *Study (Imaginary Portrait of SS Pius XII)*; 1955, oil on canvas, 108.6 x 75.6cm, UEA 30) located in the Living Area. Not only because he is attached to this particular painting but also because it happens that precisely in front of this piece there is a little seat, he likes to come back and is able to sit down. Who is involved in this spacing? Francis Bacon, as with most of his works, 'quickly and decisively' painted this picture most likely within a few days in 1955 (Peppiatt 2006, 30). Lisa and Bob Sainsbury got into contact with Bacon via his friend and dealer Erica Brausen around this time. They proceeded to act as patrons, commissioning portraits and purchasing works from Bacon in a time when he was still within their

---

26 Bill, sketching interview.

'self-imposed annual expenditure limit' (ibid. vii). The canvas and oil paint Bacon used are more durable and allow the painting to stay in the Living Area and not downstairs for extended periods. The building envelope keeps rain and wind out; the condition reports who keeps track of all movements and material changes of this object. The conservator, the registrar and the curators jointly discuss when and how the painting travels or does not travel, and the 'Bacon's travel a lot because of loans'.<sup>27</sup> The light (See Chapter 6), the maintenance network, etc. all contribute. The question here is not who or what is in control, but who and what contributes to the specific ritual.

The display, which stays more or less the same, allows Bill to return to this particular artwork. And this adds another aspect to understanding the relation of stability and spacing. The static display guides people to return and find *their* object again. '[I]t can be an incredible place for people to feel that they have ownership of it, and once people feel relaxed here, [...] it kind of promotes incredible creative responses, incredible independent research and interest',<sup>28</sup> Croose Myhill, Education Officer, explains and adds that in this relationship one starts discovering the small changes of light and shadow for example. Thus, in stability lies the possibility to experience multiplicity.

Bill, who is sitting down and enjoying the Imaginary Portrait, is a receptive or attuned actor (Mol 2010). His engagement with the world of the Sainsbury Centre is not one of an explorative 'flowing with the objects', but a specific arrangement of ritual with the art. The place becomes a connector of different spaces and times and courses of action weaving them all together and allowing Bill to return (Latour 1997). Bill is not a 'user' of the setting but he encounters these multiple connections and adds to them in the event of encountering the art. Hence, with attachment we can address the issue of control in the process of spacing, but also the issue of fidelity.

---

27 Ledinskaya, Maria (Conservator, SCVA). In-depth interview 2 by Sabine Hansmann. Norwich, 18 October 2017.

28 Croose Myhill, in-depth interview.

## 5.5 Conclusion: Multiplicity and Experience

Investigating ephemeral and mundane practices in the context of a building has its challenges and limitation. As researcher, we are not possibly able to give an overview of the abundance and variance of daily experiences that occur with a building. There are many cases that have not been considered here, visitors who explore in groups for example. Then *she* might not only follow *her* nose, attuned by the objects and guided by the rich material world but also a fellow explorer's nose. Walking attached to each other then adds to the complicated spacing of the walk a greater degree of complexity. The Sainsbury Centre not only is a place for art lovers. 'A large part of our agenda is research and study and education',<sup>29</sup> director Paul Greenhalgh emphasises. All of which tests, shifts and broadens experiences, practices that can dramatically change how people encounter the building or art. All this has not been addressed here. Following the people throughout the building never gives the full picture, but rather a mosaic of experiences, as we have similarly observed with the walking interview (Chapter 4). After collecting biographical notes, and understanding the constant flow that the building is in working-with and how agency is shared in different ways between humans and nonhumans here we turned to the modality of mundane experience with the building. The rich and diverse or eclectic reality of the building appears and we witness that various experiences coexist.

In the introduction, I explained that this chapter is dedicated to discovering the experiences of people who visit or engage temporarily with the world of the Sainsbury Centre. That said, while we approached people who spoke about and drew their experiences, these experiences are not tied to active subjects, while the material world stays passive and functions as background. Instead, following the practicalities we moved inside, into the course of action, and saw how both humans and nonhumans share experiences.

We followed people through their sketches and narrations into their engagement with the world of the Sainsbury Centre. As mentioned earlier, I could have chosen to do participatory observation or shadow my interviewees. I did this in the case of some employees, however, approaching particularly visitors, this seemed to interfere too much with their private visit, and furthermore a short anonymous interview met with the agreement of the institution. Sketching while re-thinking their path throughout the building, the material world, the many objects that facilitate, guide and impede certain activities, become visible. Like in a

---

29 Greenhalgh, in-depth interview.

walking interview, where the objects ‘do the remembering’ (Guggenheim 2009), here the empty sheet of paper or empty areas in the course of the narration ask the participant to evoke things otherwise forgotten. In this sense the sketches complement and enhance the oral part of the interview and let us witness even better the diverse experiences, practices, and attachments with the building and its material world.

From experience, every time the Sainsbury Centre is approached it is different—consisting of multiple actors. In this sense, there is not one building, not two parts, but multiple. If we have witnessed with the previous chapter that the building is always on the move, constantly changing, with this chapter we understand that in perception the building is similarly mobile. Buildings ‘can be perceived only in a cumulative series of interactions’, Yaneva stresses (2017, 37). We followed a series of interactions: the arriving and entering, the exploring and meandering, the climbing up and over-viewing and the enactment of attachment. The journey taken however should not be misunderstood as a move from outside to inside, from global to local. As we do not move *in* space but *with* space, we did not approach the building as an object in a given context. Instead we followed individual people with diverse roles and knowledge, some of whom visited for the first time, who feel disoriented and daunted, who cannot yet make sense of the spatial layout and thus hold on to some tangible anchor points. And others who come regularly, some who come to let the objects guide them around to explore new aspects and again others who move purposefully to specific sites to enjoy a particular set of attachments. To follow the trajectories of people throughout the building is revealing since, firstly, we witness diverse and nuanced humans and secondly, we witness how they interact with the building—visually, bodily and in specific course of action—and thus create specific spacings.

The building is used on different occasions, with different intentions and purposes by different people at the same time and each person creates a specific trajectory in negotiation with the building. Buildings are manifold in their possibilities. Guggenheim speaks of ‘a scattered array of interfaces that neither specifies an order nor a hierarchy of use’ (2009, 6). They ‘lack a clearly specified interface, such as a play button’ (ibid.). The spiral staircase connects the main campus with the building; it connects downstairs and upstairs, which we can describe as its function. However, people do not only *use* it to walk up and downstairs. They use it also to gain or offer (in case of the guides) an overview, to take a brake and lean on the handrail looking down. While the concept of use is already broader than that of function (Hill 2003, 14), it does not reflect the multiple and reciprocal connections involved and furthermore it does not acknowledge the quality of connection. We witness how Ms Abbey is well connected in her physical participation, walking down the stairs focusing on the rubber floor on the steps. We learn that the Smiths in their encounter with the building lack some actors in their network

for a smooth arrival which adds to her insecurity and which further increases when entering the large interior confronting the field of art objects. While others meander *with* the art object, travelling from here to there encountering multiple spaces in flux, this poses challenges if not mediated by adequate knowledge. The monospace confronts people directly with art, it does not provide guidance by corridors, it does not structure the journey along rooms; it does not portion the trip into manageable and predictable smaller steps. Although the way to the visitor counter seems to be an important first anchor, the building shows itself rather indifferent to any fears of unmediated contact with art. Thus, while some people can enjoy negotiating every turn left or right with the objects creating a unique trajectory that speeds up when an object caught their interest and intensifies when delving in an attachment with a specific piece of art, this constant unpredictability in negotiation can also be overwhelming and demanding. Yet for people who visit the Sainsbury Centre more often, and who move accompanied with a detailed knowledge of the different negotiations at every turn, predictability emerges through the stability of the setting allowing for heterogeneity every time the doors are opened.

Approaching spacing through the experiences of visitors we witness systems of mediated interaction. Each trajectory is unique and emerges out of the entanglements with different ingredients. Turning to spacing particularly allows including non-authoritative voices and acknowledging the people who engage with architecture in a mundane way. Thus, spacing does not only help us to overcome a general dichotomy between materiality and the social but also the subtler dichotomy of architect and the people using a building.

While we do not witness courses of action that could be called an anti-programme in a functional understanding, approaching spacing we become aware that there are countless courses of action which coexist and which produce countless coexisting spaces. The sketching interviews reveal how people connect in diverse experiences with the building and clearly show that these experiences are never about the whole building as a static object but rather about the possibilities that develop in action with different intensities and frequencies—in and through and with the building.





## 6

### In Practice III: Lighting

---

With the last two chapters, we gradually gained a different understanding of the architecture of the Sainsbury Centre. Not a static architectural body, a white box that contains a lot of space, but many elements of the building and specific practices came to the fore as we moved closer and followed people in their engagement with the building. Firstly, we witnessed how working-with is a constant re-thinking, re-shaping, and re-negotiating of material arrangements and sets of practices as ingredients for spacing. In following this work we gained an understanding for the shared agency between humans and nonhumans in changing ingredients of spacing or in spacing itself (Chapter 4). Furthermore, by approaching mundane courses of action we traced the multiplicity of experience in spacing (Chapter 5). Thus, we gained an understanding for the diversity of people and the manifold of possibilities with the building. All of which shifts our understanding of a static unified object, which contains space to a decentred building of many mediating elements with a multiplicity of spacing possibilities.

With this chapter, we will go into greater detail. We will pay particular attention to the role that nonhumans and the material world play in spacing. In their capacity to hold different times and spaces in place, above all, the focus on objects in this chapter will help us to understand the complicated nature of spacing.<sup>1</sup> Earlier, we addressed how the materials and objects of the Sainsbury Centre have been purposefully chosen and designed by planners or curators and have been tailored by knowledgeable workers and craftsmen (Chapter 4). And that these people anticipated and still anticipate specific 'scripts of action' with each change in the material arrangement (Akrich 1992; Latour 1994). For instance, putting a new temporary exhibition in place or changing the lighting can be described as a purposeful inscribing of action. However, the scripts are not simply extracted, but negotiated. There is always the possibility to negotiate scripts in

---

1 See Latour (2005, 199 ff.) in comparison to what face-to-face interactions are not able to deliver.

the process of ‘de-description’ in the interaction between people, building and objects, as discussed in terms of the Living Area (Chapter 4.4). The specificity of the Sainsbury Centre, however, is unlike most other buildings as we have seen because the architects have never left the site. Foster and Partners do not only act indirectly through the many connections they have put in place—but moreover they are present designing and overlooking all major changes that have been made to the building since its beginning.

Since this study has not set out to re-tell the story of the designer’s hand creating a space but to trace the many spaces that emerge in the daily life of a building we will try to leave behind the idea of ‘human genius’. Unravelling the knot of action we see how every spacing not only connects different times and places but is also of different material quality: patrons, architect, plans, glass, UV filter, light, art object, viewer. Just to give one example, the glass fitted with UV film continues to act when the many humans have already left the scene. And this is why we have to move forward and backward throughout history. There are many elements in place that take part in these interactions and they have been put in place in different times throughout the past 40 years and might even lead further back in history. In addition, these elements will lead us to different locations. It is not only the collection of Robert and Lisa Sainsbury that connects the Sainsbury Centre to different sites around the world, but anything that is acting today is never acting alone, without multiple connections. Thus, in order to take into account the spacing of the Sainsbury Centre, we will need to travel both in time but also to other spaces. This is not, however, an extensive re-collection of the history in a chronological or geographical manner. We will only approach the history or different locations when it makes itself present and where it makes a difference today.

After all, this chapter also keeps us tracking the building in its complex and diverse reality—this time by following light. Light is connecting countless actors and in *doing the light* countless actors become connected. Light was in the process of modification during the course of my research. Light in the building is not simply there, but there is a constant concern about the quality and intensity of light, and with it, concerns about visibility and connectivity, and thus, about possible processes of spacing and experience. What does light do? How can a coloured shadow stimulate thinking? How can it move us?

Again, before plunging into this chapter, let us briefly review the tools I apply to trace light. Structuring this chapter along three settings, each opening with an ethnographically inspired account, this chapter combined the observations and experiences of an outsider (myself) with insider knowledge from the in-depth interviews.

## 6.1 Tracing the Object

To move deeper into the world of the Sainsbury Centre each of the following accounts starts off with an experience of light based on my experience as an architect and based on the experience of other people through observation and interviews during my research visits to the Sainsbury Centre. These accounts do not approach a phenomenological experience, they are not auto-ethnographical, but follow a pragmatist tradition as explored with the last chapter. The writing strategy aims at taking the reader into the particular experience. Here, various actors are present, including myself. I contribute to spacing and am part of the entanglement in action. Therefore, I am visible in all of these accounts. All accounts of the Sainsbury Centre were written immediately during and after visits based on my field notes. In that they are not 'stories' but carefully chosen examples, they should immerse the reader into the world of the building.

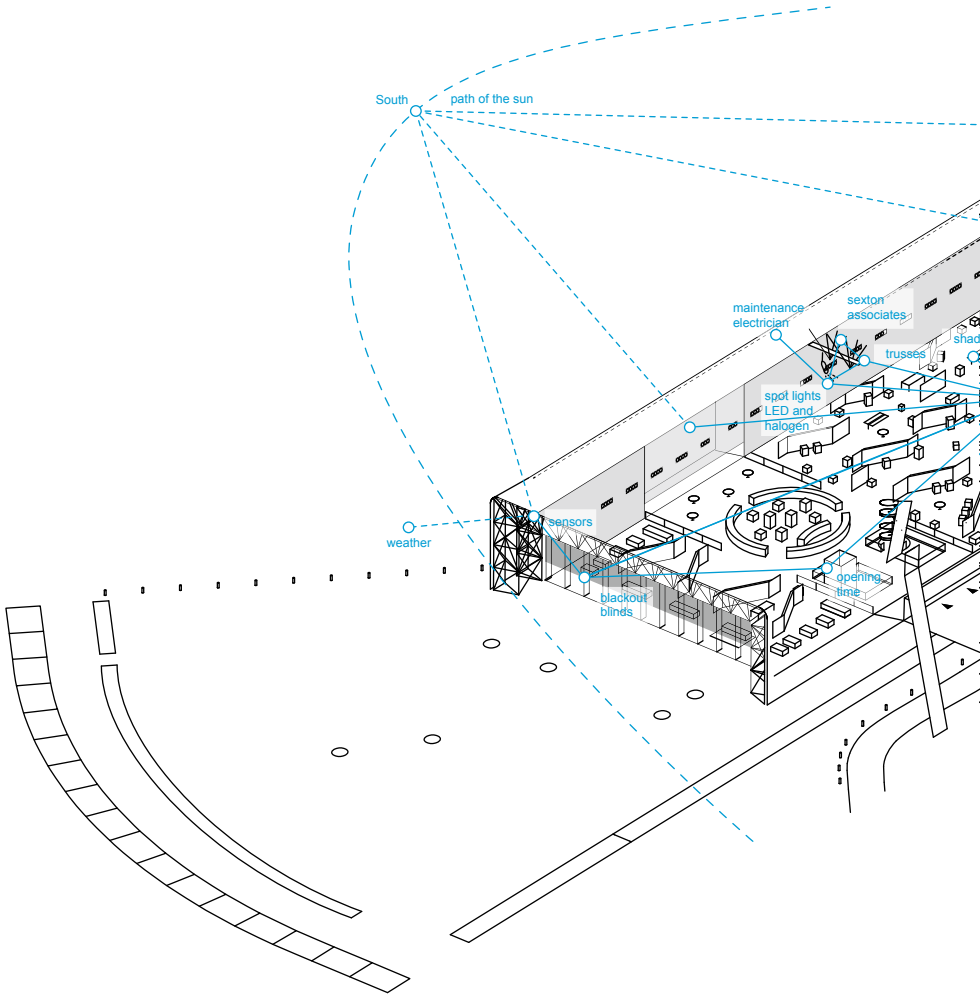
Once again, we witness the bridging quality of experience that allows us to pass over the distinction between the objective or subjective world of a building. These accounts will thus allow us to see the richness and complexity and to carefully unpack what happens *in* and *with* space, *who* and *what* contributes to a course of action. And this time we put a particular stress on *what* contributes and how. Each setting consists of a dense description of observation and pictures, the latter showing central actors in the setting. Again, I do not provide separate captions introducing these actors, since the pictures are part of the ethnographic account. All these accounts come together in a reduced and simplified version in the isometric diagram of the building (Fig. 6.1). Tracing the network of light this sketch allows the reader to travel the three subchapters in a non-linear way, moving into detailed descriptions and following the light with this map in hand.

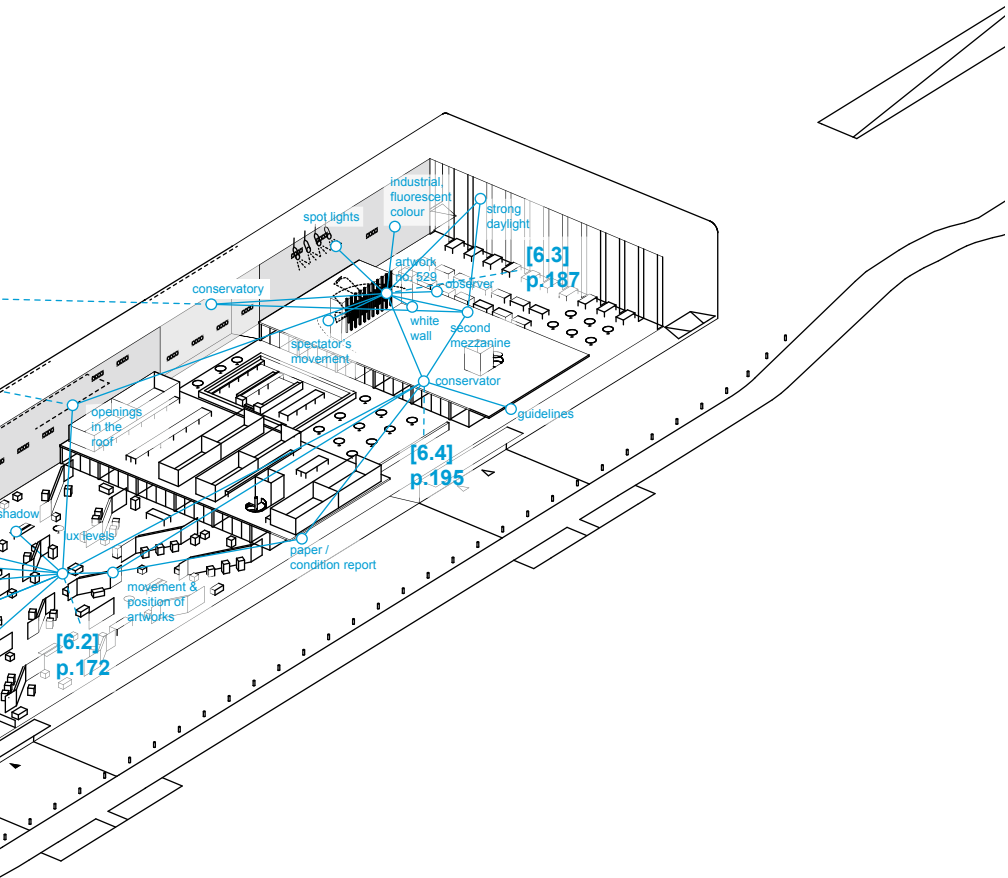
Firstly, we will return to the building to find it changed. A device has broken down and in what follows we will witness the testing out of new experiences—an experimentation with light. Aiming for the most comprehensible account of complexity possible, we start off with the 'natural light' that is entering the building and follow its filtering, co-production and distribution by many mediators.<sup>2</sup> Contrary to what we might imagine, the world of light is far from 'light' and ethereal, but heavy, full of mediators.

Secondly, we approach artificial light, which is not disconnected from natural light. Instead, we will determine that light is mixed and layered, guiding together, along with many other devices, human experience. Here, we will follow a visitor interacting with a piece of art. Who is in control?

---

2 I use the term 'natural light' in distinction to artificial light. Considering the anthropogenic change of earth's atmosphere, I would like to point out here that this light is already 'made' and is not 'natural' in the actual sense of the word.





**Fig. 6.1:**

Isometric view tracing the network of light as visible in the three settings. The doing of light emerges out of a complex socio-technical network. A variety of material and immaterial spacing devices work together to shape, diffuse and carry light.

Thirdly and lastly, we will join the dismantling of an exhibition. Following the conservator, who is concerned with the well being of the art objects, we can enter the controversies around the issue of light and see how the art is guiding new lighting policies.

## 6.2 Opening Up and Spreading



**Fig. 6.2**

### First Setting

Date: Saturday May 13, 2017 / Monday May 15, 2017

Location: Gallery entrance and Living Area / School entrance and roof trusses

I had not been at the Sainsbury Centre for a couple of months. I enter the building on this Saturday afternoon and it is like entering a cave. It is remarkably dark in there. I can recognise that the blackout blinds at the east end façade are half down; a position that I have not seen before. It is not particularly sunny outside. So why are the blackout blinds down, and why only halfway?

I turn to one of the women at the reception. At first, she avoids providing an answer. However, after sharing my knowledge about the system I learn that

the blinds are broken. The blackout curtain is down and it is broken; a technical failure; thus: less light in the building.

On the following Monday morning, I enter the building through the university entrance. Turning left I pass under the first mezzanine. I am stopped. There are not only portable barrier stanchions with retractable belts and an information panel ('Galleries Closed; Opening Time: Tuesday—Friday 10:00–18:00. Saturday—Sunday 10:00–17:00. Access to Robert Sainsbury Library for students and staff. All other visitors report to Security desk. Thank you'), that hinders me from walking directly into the Living Area and re-directs my walk to the Security desk but there are also portable yellow barriers catching my attention. 'Danger. Man working overhead (contact gallery assistant if access required)' is written on them. One is standing on the floor and a second is hanging on the metal handle of the glass door to the Living Area, which I find closed for the first time—a door that I actually recognise for the first time. The gallery assistants, located right next to the scene behind a counter, with a view onto this door and through the glass wall into the Living Area, share with me that the light bulbs will be changed today at noon and additionally somebody from Sexton Associates, the lighting consultant, is there to adjust exposure. Three men are standing in the middle of the Living Area in the middle of discussion; they point up and look at some notes.

Later in the afternoon, I find one of them laying on the bottom of a metal truss in the roof, a thin metal grill to his left and right protecting so that he cannot fall down while reaching out for a spotlight. He is far from where I am standing—high up in the roof.

He gets up, looks at his notes. Pauses. Leaves this truss and walks to the middle of the next truss. He stops and looks down, looks at his notes and walks back to where he came from.

### 6.2.1 Who Does the Light?

There seems to be a world of 'making light' that is connected to many devices: glass, blind system, light bulbs, closure (the Museum is closed on Mondays), lack of a corridor (thus the need to close the whole Living Area when working overhead), barrier system, art, Sexton Associates, trusses in the roof, notes, etc. They all seem to be somehow involved with the modality of light—a network of lighting.

The breaking down of the blackout blinds are what force light to become a noticeable issue at the Sainsbury Centre. Apparently, there are changes going on that I had not noticed before and which nobody had mentioned in the interviews. Why is it dark in the gallery space? Previously, I had taken the light for granted. I had seen beautiful small points of sunlight wandering across the floor and walls

of the Living Area and Winner had touched on the topic of light during the walking interview in relation to the blind system (Chapter 4). Apart from that, however, I had not paid much attention to the light. In other words, I had taken light as an aesthetic quality of architecture; I had taken it for granted. Obviously, this was due to my view from the outside, a very partial view. And this seems to hold true to most visitors. There had been many comments on the light during the sketching interviews (Chapter 5): ‘the building is spacious with lots of lights’, ‘lighting is indirect’, ‘different levels of light’, ‘it is airy’, ‘views are lovely’, ‘gives a sense of light’, but none of these rather atmospheric descriptions touch the internal complexity of light. This is where we come back to the phenomenon of black-boxing (Chapter 4.3). Just as we commonly approach the building as a black box, we approach light as a black box. The malfunctioning, the dark gallery space, points towards a crisis in the joint ‘production of actors and artifacts’ (Latour 1999a, 183). The blackout blind had worked as a silent and smooth intermediary until its crisis points towards its associations with many other actors. The light, which as a result I am forced to recognise fully, had been rendered invisible by its own success.

Actually light in a museum is always a concern, always in the process of negotiation between the conservation of artefacts and the experience of the art.<sup>3</sup> This turns out to hold particularly true of the Sainsbury Centre that uses both daylight and artificial light and that has objects that are very sensitive to light on view. At the same time, the Sainsbury Centre tries as an institution to follow the legacy of its patrons who wanted their collection to be shown in a relaxed atmosphere, with natural light (Rybczynski 2011, 141).

Let us pause for a moment and open the black box of light. We briefly touched on so many actors, all somehow involved in *doing the light*. What do they do? How and where? We follow the natural light first—how it enters the building and spreads—before slowly moving deeper into this complex socio-technical world of light that is mixed, focused and layered, monitored, tabularised and mapped, and that involves, guides, and also hinders many moves. Light is a very active player in the world of the Sainsbury Centre and it leads us in countless directions throughout the monospace as it is present in all spacings—in its positive or negative value.

### 6.2.2 Letting the Light Show Through

The broken double-layer blind system that set off my journey into the light was installed in 2014. One layer is a solar blind, which filters most of the solar light while still being transparent, and the other is a blackout blind. They work automatically, guided by the weather outside. Sensors inside and outside of the building measure the light intensity and close the blackout blinds if necessary. Addi-

---

3 For a general introduction into the negotiation between museum environments and experience see Thomson (1978) and Cuttle (2007).



tionally, the blackout blinds are down always whenever the Gallery is closed to keep unnecessary natural light out. This blind system had replaced the venetian blinds that had been closed most of the time. The idea of a blind system that replaces the original venetian blind was controversial, particularly as the building was already listed by Historic England at that point. Winner recalls, “There was a lot discussion with the list, the planning, because of course it had been Venetian and we change[d] it. [...] [T]he way they were convinced was by showing then that actually having the blinds down was not a normal condition. The normal condition would be the blinds are up so you should not be listing something that’s in the closed [position], you should do it when it is up.<sup>4</sup> But having the blinds up, was not possible due to the potential damage to the artworks through the light and ‘anecdotally they [the venetian blinds] never really worked from the very beginning—or they worked for a bit, broke, were too expensive to repair, [so] we left them closed.’<sup>5</sup> The solution to install the double-layer blind system eventually allowed the *opening up* of the east end view onto the surrounding landscape again, always with a thin layer of fabric, the solar blind that *filters* the light, in between. Hence, the solar blind allows the light to enter again, and enables a view onto the outside, but it does this only with the help of the glass. The pre-condition of the solar blind to do its work is the transparency of the glass. The exterior envelope of the building is perforated and allows for a lot of natural light inside (see Chapter 3.1). Transparency is a crucial modality if we want to follow the natural light on this trajectory to the inside.

The most iconic images from the Sainsbury Centre show either end of the building, like the view from the lake by night, when the inside is captured with reflections in the water. By night the glass becomes wholly transparent, when there are no reflected light distortions or mirror we can see directly inside from the outside. The two glass façades of the Sainsbury Centre are even a bit more transparent because they are made without a further support system of metal posts. The glass of the two 30 x 7.5m end walls is load-bearing and each glass wall with 12 panels of annealed glass is stiffened against wind loads with glass fins. One way that we could explain these all-glass façades would be to follow the claim to transparency of modern architecture that has been quite controversial in architectural theory (Vidler 1992). The origin of the term ‘transparency’ in architecture is not bound to the development of the use of glass, but Forty distinguished three modes of transparency—the ‘literal’, the ‘phenomenal’ and ‘meaning’—that give it a broader significance (Forty 2004, particularly 286–88). Nevertheless, as we are concerned with the very material world in this chapter, let us not lose track of the

---

4 Winner, walking interview.

5 Ibid.

formal gesture and its meaning. Rather, we are interested in what the glass actually does and how it participates in the inside of the building.

Glass *allows* the visible light to pass through. It allows the movement of the light from outside to inside, the *passage of light*. But this passage of light does not occur without consequences, as light carries with it some damaging effects. The glass is not transparent to infrared light, though, and thus, especially the glass end walls, causes a greenhouse effect, which is one reason, amongst others (e.g. lack of temperature and humidity buffering materials, low thermal mass), for the comparatively high microclimate variability in the SCVA (Camuffo 2001). With the re-cladding of the whole building during Spring 1988 and in the course of the construction of the underground connection to the Crescent Wing replacements of the glass panels took place (Rybczynski 2011, 178, 210).

New glass panels installed had been fitted with neutral density UV film, and it is said, that there is barely any UV light in the building today, which is potentially particularly damaging to the works of art. Nevertheless, 'all light is damaging to the collections'.<sup>6</sup> That is why the move of opening the building up to the landscape and allowing for daylight in the gallery space (a decision made in the 1970s) is accompanied by countless humans and nonhumans who filter, shape and react to and interact with the light in a way today, that it is not or, at least, less damaging to the works of art. They all contribute to the making of the light and share agency in the network of lighting. Light is an essential as much as controversial ingredient to spacing that requires a lot of collective effort particularly because the monospace allows the light to travel.

Glass allows the passage of light into the building. Let us look at the etymology of the word 'transparency.' the word transparent leads back to the Medieval Latin 'transparent-em', the present participle of *transparere* which consists of *trans-* ('across, to or on the farther side of, beyond, over') and *parere* ('to appear, be visible') (Oxford English Dictionary 1989a). The transparency of the glass does not only guide the light through but also allows for things to appear, to come to light—which leads us to a general feature of the building. The light that is *shown though* by the glass spreads in the building in a very specific way and allows the art to appear, to be seen. This is the Janus-faced nature of light: it allows the art objects to be seen, but can also damage them. In that it enables and facilitates as much as it impedes and prohibits many spacings.

---

6 Ledinskaya, in-depth interview 1.

### 6.2.3 The Generosity of Light

Sitting on the second mezzanine and facing a computer a graduate student, is able to see the greenery of the landscape on the white wall in front of her (Fig. 6.3). The landscape is not only present inside the building because the glass in combination with the translucent blinds allows looking outside, because the *light is shown though*, but additionally shiny surfaces all over the building draw light in and spread it. These surfaces allow the light to become a connective power. Depending on the weather, outside reflections appear and disappear, and with them multiple visual connections happen that even wrap around corners. If we follow the connective power of the trajectory of light, we can make our way through the building. Not in the sense of moving in space, but in following the network of light that connects different actors, and facilitates and demands certain courses of action (Fig. 6.1).

From downstairs in Gallery 1, it is possible to follow people entering the monospace upstairs in the glass railing that encloses the connecting holes between the two floors. Sitting in the middle of the school area or at the Gallery Assistants counter, it is equally possible to follow the coming and going at the school entrance in the back around the corner. The glass walls under the mezzanines and the glass finish of the white furniture in the school area and in the mezzanine, in the café and the shop, all re-arrange the bright natural light and create clear reflections that allow one to see 'elsewhere' in the building. Less shiny but nevertheless reflective, the slats along the walls and roof, and the plastic flooring in the museum entrance area re-distribute light in the building (Fig. 6.4, 6.5). As soon as there is a bit of sun, the green of the trees outside of the restaurant is drawn deeply into the building along these slats of the inner skin. All these materials connect the inside to the outside of the building but also leads to multiple engagements. All these devices make the light move and it is a specific feature of the monospace that allows for particularly rich experiences.

Such things do not create loud effects, but rather discrete movements, always unpredictable and different throughout the day. In interaction with people, individual movements and reflections visually occur and change, connections arise and disappear again—light permits seeing with all these devices. Thereby, the connective property of light is equally affiliated with its absence, the shadows that also populate the building. As Dan Rycroft, who is working in the Department of Art History and World Art Studies, emphasises, '[s]o it's not really only about brightness but also about the reflections and the shadows, because those are really what change the most, and if you are a regular user of the building, you can actually pick up and appreciate.' He continues, '[s]o even just the fact, I'm looking here, this is a shiny or reflective surface, means you've got some engagement with what's over there, namely the window and the grass and

so forth.<sup>7</sup> We experience these multiple reflections mainly on vertical surfaces. This is vertical light, as lighting and museum designer Sexton explains, and the louvre system in the roof is centrally engaged with providing the surfaces with this kind of light (Fig. 6.6).<sup>8</sup>

There are two layers of louvres in the roof scattering the light that enters through the four glazed strips on the top of the building. The upper blinds below the skylights are motorised but controlled by a system that in fact is based on a timer, which means that it does not react to the actual daylight. This layer was kept shut during my research, and I often hear that it is broken. This may or may not be true, even when the louvres are closed, light still falls in. But, this light is not simply there, a pure light, but is shaped by the louvre system. Sexton explains that in traditional galleries with laylight the light fills the space but the floor catches all the light in the most direct manner and becomes the brightest element in space while less light rises to the vertical surface.<sup>9</sup> Due to the louvre system, however, this is not the case in the Sainsbury Centre:

Even though it is directional, it [the louvre system] tends to put more light on vertical surfaces. Which means your eye is looking more at things on a vertical surface, which is where the art is displayed. And then you have the artificial light, which is really directed entirely at the objects and at the vertical surfaces, the display planes. And therefore, I think there's a sense of overall *generosity of light*. But still there's an emphasis, although it's a very imperceptible and subtle emphasis. It's really focused entirely on the objects in the vertical surfaces, the display surfaces. That's what gives it a special quality.<sup>10</sup>

A quality that Sexton specifies as a 'materiality' that the light has in this building. Light is *heavy* in the Sainsbury Centre. Actually, there are a lot of materials throughout the building, which have reflective surfaces and support the verticality of the light.

Thus, light is not *falling* but it moves throughout the building, it bounces and jumps and it is guided in its trajectory by many devices. It is made with many materials, supported by a louvre system that enables light to spread, not only to

---

7 Rycroft, Daniel (Lecturer in the Arts and Cultures, UEA). In-depth interview by Sabine Hansmann. Norwich, 17 August 2016.

8 Sexton and Geitner, in-depth interview.

9 See Christopher Cuttle (2007) for a general introduction to the different approaches to museum lighting and in particular the different daylighting typologies. Concerning the Sainsbury Centre, Cuttle emphasises that a large room of this kind must be 'well-lit' in order to be effective (ibid. 250 ff.).

10 Sexton in: Sexton and Geitner, in-depth interview; emphasis added.

ground surfaces, but vertically, to vertical surfaces—like art objects. This is a light that renders visible through its materiality, its devices, its generous technical systems—they make the light generous. And they make light able to facilitate in generosity the daily spacings in and with the Sainsbury Centre.

This ‘overall generosity of light’,<sup>11</sup> that Sexton emphasises, is highly compromised on that Saturday afternoon in May 2017 when I walk into the building. Instead, the building is rather moody. It is dark in the building because Ledinskaya, the conservator, introduced a new light policy during the summer season in 2017. A policy that tries to adapt the artificial light to the rhythm of the natural light. Daylight, even if it is filtered by many layers and distributed by different surfaces and forms and in this sense is transformed and manipulated technically, remains ephemeral and subject to the weather, the day and the seasons. In principle, more daylight can be expected in the summer months. Hence, Ledinskaya advised keeping the screen lights in the Living Area switched off and only the spotlights turned on. These spotlights highlight singular pieces of art, and disperse and scatter little light away from these areas. But it is tricky to get the balance right. Ledinskaya’s attempts coincided with the blinds breaking down. The result: the environment stayed rather dark, while the art started to glow.

This allows another aspect of light to be seen, it not only moves around the building, but also, in the Sainsbury Centre, is layered. There is the natural light with all its mediators and there is the artificial light. They work together to make us see and to change our trajectories and they do this with the help of many devices. If one device has broken down, as the blind system did, the ratio falls out of balance. The interior experience in general and the experience of the art in particular depend very much on the subtlety of the light. Ledinskaya’s new light policy is driven by the attempt to reduce the potentially damaging impact of light on the artworks and this is a long-term project. Comparing earlier images of the Living Area to the experience of the interior today, the amount of daylight has been dramatically reduced. The primary source of illumination today is electric light. Nevertheless, I can witness dappled light that wanders across the floor, along the walls, and over showcases on sunny days (Fig. 6.7). Not only are these strains shaped by material means but the sophisticated systems of filtering mechanisms that shape the quality and intensity of the natural light throughout the whole building—essentially allowing it to open up the building to the landscape. In this sense, natural light *is made* in and with the building and with all these different devices just in the same way as artificial light is made.

---

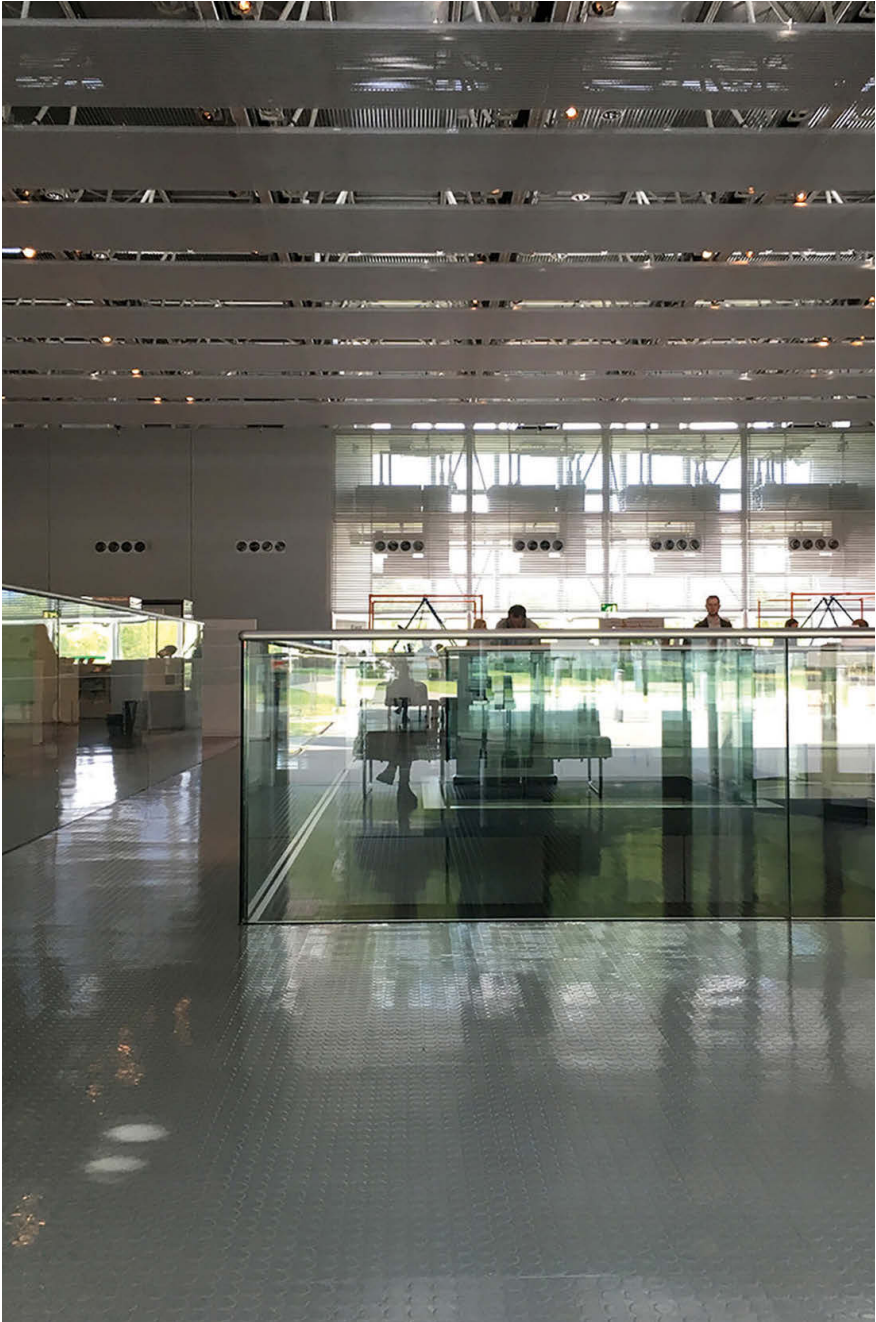
11 Ibid.

Understanding the heaviness of light means understanding how this vivid and important actor in the course of spacing is in itself dependent on many other actors who do the work and convey the light. Entering the Sainsbury Centre we do not enter 'a single, light-filled space' (Foster + Partners, 2018); instead we connect with light and through light with a multiplicity of devices. As an ingredient for spacing in a museum setting it is controlled and curated however, the network of light is in experimentation throughout my research and thus in a moment of instability that allows me to witness the negotiations that occur with it. While I became aware of the issue of light because of the breakdown of the blind system, there are other occasions, which let us witness how light is an important actor in spacing, how it guides and changes trajectories.



**Fig. 6.3:**

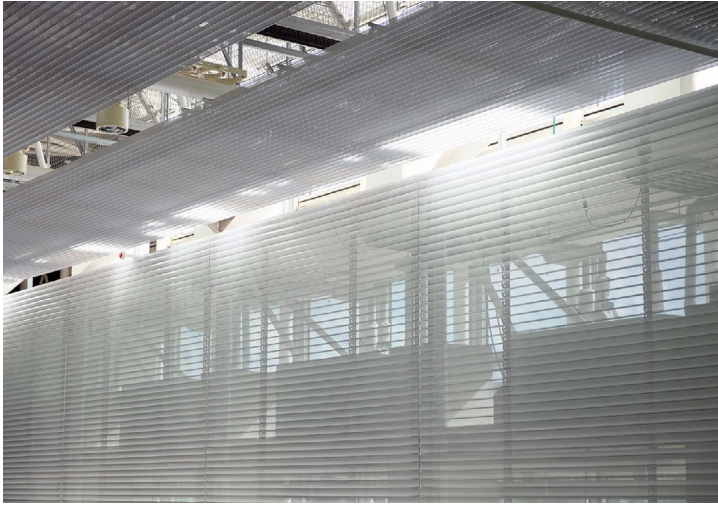
Student in front of her Computer (2017). Light reflections on the wall connect her to the outside.



**Fig. 6.4:**

Glass railings in the entrance area but also the rubber floors convey the light (2017).



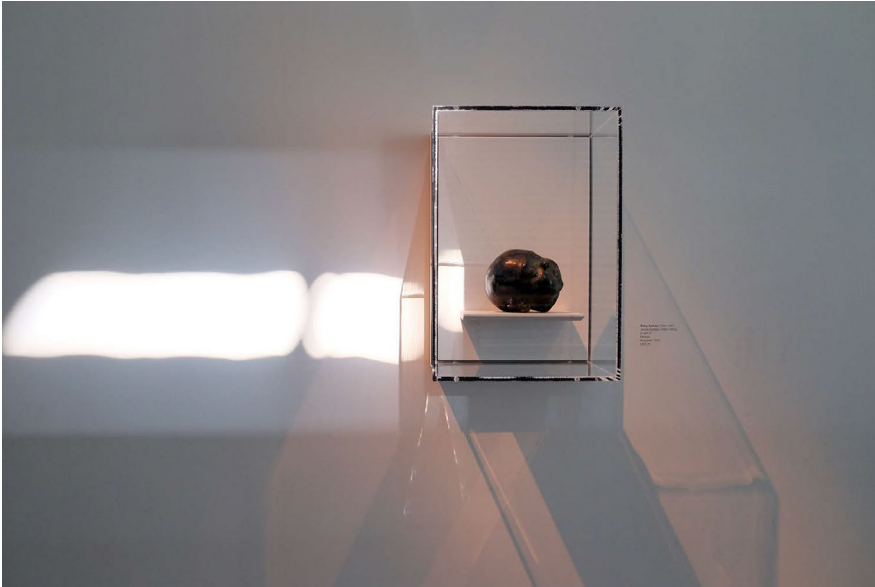


**Fig. 6.5:**

Slats along the wall and the roof (partially perforated) (2017).

**Fig. 6.6:**

In between the louvre system in the roof (2016).  
The upper layer stops most of the light from falling in.



**Fig. 6.7:**  
*Baby Asleep* by Jacob Epstein with combination of sun light and artificial spot light (2017).

**Fig. 6.8:**  
A theatre fabric on both sides at the edge of the second mezzanine should reduce the amount of light for the artworks (2017).



**Fig. 6.9:**

Living Area in cleaning light (August 2017).

**Fig. 6.10:**

Living Area in spot light (August 2017).



**Fig. 6.11:**

Smith's collection of used light bulbs (2016).

A hawkers's tray helps him on his morning tour throughout the building.

### 6.3 Layering

Rana Begum's exhibition *Space Light Colour* is still in place when I return in summer 2017.<sup>12</sup> I had visited it in May of the same year just after its opening more or less as a 'hasty sightseer',<sup>13</sup> but decided to return, to slow down, and take a closer look at this temporary exhibition. Located in the Mezzanine Gallery, it is the third show that I am able to experience here during my research. However, it is the first one that does not utilise a theatre curtain, a light grey fabric extending between the ceiling and the bottom edge of the mezzanine, to prevent the pieces of art from direct daylight (Fig. 6.8). Thus, cutting off the visual connectivity of the building, the transparency from one end to the other, it stops the light in its movement, which makes a difference in how we are able to spatially experience the mezzanine. But there is another reason why I am interested in this exhibition.

In the exhibition brochure I read that Rana Begum's 'practice blurs the boundaries between sculpture, painting and architecture, and has a transformative, sensory and immersive quality' (Sainsbury Center 2017). But what does Begum's art practice have to do with a concept of space committed to the idea of movement and interaction rather than the enclosed and static spaces of a container space? Immersive art intrinsically allows questioning the borders that 'container space' assumes: the art object produces the space; it is not placed *in* the container space. Blurring the boundaries between art and spectator is an old topos in art, where immersion disperses the distance, the clear distinction between the 'subjective' and 'objective' part of an experience. Instead, spectators become part of the art production. However, I am not going to enter an art historical discourse here. Let us move closer into the exhibition and see how it can take us back to architecture and spacing.

It is summer and there are only two weeks left until the Paul Nash exhibit ends (8 April–20 August 2017), a major exhibition downstairs that spans all three galleries. One of the receptionists explains to me that, often, with the end of an exhibition, visitors are naturally drawn in. However, since the Begum exhibition,

---

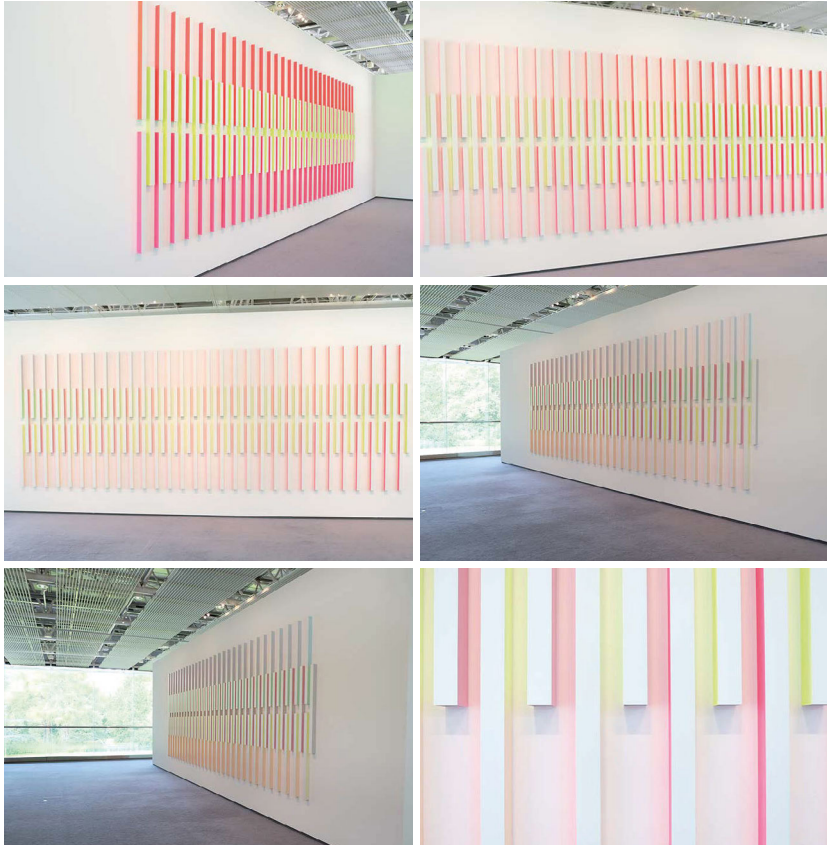
12 Rana Begum is a visual artist who lives and works in London. The exhibition *Space Light Colour* at the Sainsbury Centre (12 May–15 October 2017) is her first solo museum exhibition, which spans the entire gallery mezzanine. Begum describes her art through the adjectives 'abstract', 'minimal', 'colourful', 'architectural' and localised 'between painting and sculpture' (in-depth interview, 9 August 2017). The exhibition comprises an extensive walk-in installation (No.670, mesh installation), objects like the folds and bar pieces to which work No. 529 belongs and a selection of models from some of her public art projects. The artist explicitly appreciated the opportunity to exhibit her art in the upper part of the building because of its quality of natural light.

13 On the 'hasty sightseer' and 'the slow ethnographer', see Yaneva (2013).

which overlaps with the Paul Nash exhibit, is on until October it will probably be rather quiet during my research visit.

I am there to follow visitors, to track their movements, to see how they interact with and how they are guided by the art. I want to learn more about the relation between the art and the architecture in its widest sense, all the different devices and actions that are necessary to present the art, to keep it in place and how this scenography might differ from the permanent collection of the Centre.

This time I stay for seven days and come up into the Mezzanine Gallery again and again, as often as possible in between prearranged interviews; and on Saturday and Sunday I stay longer as I do not have any obligations. Often I see people walking into the exhibition from downstairs, while having an interview in the school area or on the first mezzanine. I witness adults and children both using the neon coloured jackets provided in the entrance area under the mezzanine, I see them walking along the glass railing looking down into the school area, and I see a lot of them using their mobile phones to take pictures of the art and themselves in front of the art. That is also the case this Saturday.



**Fig. 6.12**

## Second Setting

Date: Saturday August 12, 2017; 11:40 am

Location: Second mezzanine; exhibition *Space Light Colour* by Rana Begum

I am still downstairs in the school area. A man holding a folded information brochure with both hands behind his back walks along the railing. He seems to be the only visitor on the mezzanine at this moment. I go upstairs—I walk underneath the mezzanine, climb the spiral staircase, pass the mesh installation (artwork No.670, 2016) at the entrance to the exhibition and greet the invigilator on her chair sitting and reading a book. Approaching the rear area of the exhibition I find the same visitor standing in front of a centrally positioned grey visitor bench.

Bending forward, with both hands resting on the bench, he is reading the visitor book, where people can add comments about their visit.

He leaves this position. He gains distance from the bench and looks at artwork No. 529, a hanging work that consists of three interlocking rows of square coloured metal rods. He pauses. He seems to dither, then walks straight back to the bench, kneels down on the carpet, takes up the pen and starts writing.

I leave the scene for a moment and turn towards the restaurant to take some notes in my notebook that I place on the metal handrail in order to write. I turn around again and find him still reading in the same kneeling position. All of a sudden, he gets up from his writing position and walks around the bench close to the right corner of No. 529. He stands there. Close. Very close. Moves his head. Moves two, three steps left—a little backwards—forward to his initial position. He raises one hand up and in between the two metal sections.

Again, moving his head.

A quick burst along the work to its left end—Stop. He looks back to where he came from. Turns firmly around and leaves the work to view it from a distance. Again, his body is kept in motion and he shifts his position several times over here, and then he walks towards the work and its centre.

He turns back and leaves the scene around the corner of the exhibition wall.

I am still there, leaning against the glass railing at the edge of the mezzanine and decide to sit down and use the silence to complete my notes and to, later, browse the visitor book on the grey bench.

With nobody else to observe in sight, I leaf through the booklet once and a second time. I cannot find his entry.

To my surprise he turns up again. He has put on one of the neon coloured jackets. Again piece No. 529. He walks all the way alongside it. Moving his head, changing his position. Back and forth. Examining.

And then he walks down to me and asks: 'Do you think she is cheating?'

I am confused. I stand up.

—'I don't think so,—no,—I am absolutely sure, she is not.'

Together we walk back to the wall.

— The reddish line of reflection on the wall is straight, he explains, while the yellow reflection is rather blurry and unclear.

I had not noticed this difference before.

Now both of us are moving very close. Turning our heads. Left. A bit to the right—bending forward. Closer.

I step back and turn around and point towards the light sources. Four spotlights up there are pointing in our direction. This does not explain the blurry-



ness of the yellow but the four subtle lines of shades of red that are visible in the close-up.

– ‘She is not cheating,’ I repeat to myself referring to this connection.

### 6.3.1 Moving with Intensities

Let us step back and recollect what we experience in this scene. Following me with this little ethnographic piece into an event of spacing in the Rana Begum exhibition we can witness how spacing emerges out of a specific coming together of different actors. At first glance we see a visitor, who moves along in relation to a work of art, constantly changing his position. Who stops for a moment and speeds up in the next. Is he concerned with the full perception of the different colour nuances or with a physical understanding of what he sees? Perhaps both. This moment takes over and guides him, as far as I can see. But let us slow down and take a second glance. Once again, there are many devices that create and interact in this specific situation. Who is present? The natural light that is *shown through* by the extensive glazing on the north end façade, the conservatory in the school area and roof top lights, the overwhelmed visitor, the artist, the assistant who carefully sprayed metal bars in Begum’s studio in London, the visitor book and all the voices that the visitor read, the soft carpet that is comfortable enough to kneel down on and the white wall, the spot lights. They, and many more including myself, are all woven together in this interaction—we all come together in this specific event of spacing which develops along different intensities.<sup>14</sup>

At the centre of this event is object No. 529. A piece of art, that consist of 90 metal bars hung in three interlocking rows on the white wall. The front of each bar is kept white, while the sides are coloured. The artist works with different colours in this piece: fluorescent colours (pink, yellow and orange) on the one side and more pastel colours (grey, light blue and yellow) on the other side of the metal bars. Both sides of each bar are a homogeneous monochrome but when opposed the pastel side reflects the fluorescent colour—‘it’s bouncing onto the other side’.<sup>15</sup> To see the layering of the colours, the mixes and nuances, the spectator has to move. ‘You can’t really fully experience the artwork completely without the viewer, or the spectator moving around and really taking in the work’,<sup>16</sup> Begum explains. Begum’s work plays with light and shadow, and the infinite nuances of colours glowing in light; light that is reflected and absorbed by different surfaces. To see

---

14 Latour (1997) conceptualises spacing outside of ‘objective’ and ‘subjective’ time and space. Instead he points to its processual nature that develops with *intensity* which he uses to ‘shift attention to the labor that goes into the fabrication of [both] space and time [...]’ (Ibid. 179)

15 Begum, Rana (Visual Artist). In-depth interview by Sabine Hansmann. London, 9 August 2017.

16 Ibid.

the spectra of colours, spectators have to change their position. The fine shades of colour on the wall, which the visitor tried to unravel, are created by the interplay of colour, material surface, and light. We can see the colours because the light is bouncing, jumping from one surface to the next.

This brings us back to my introductory question regarding why this exhibition is so fruitful for the concept of spacing. The boundary between art and spectator is not blurred by means of emotion but by means of sensory awareness. The spectator becomes aware of his or her body in relation to different art pieces in this exhibition, he or she becomes aware of the light, the colours and forms, and the relation of all four. The artist is not present in this interplay. Using industrial material and repeated modular components, artificial, industrial colours and application processes that avoid a gestural brushstroke, Begum's art is *impersonal*. Form, colour, and light interact with the spectator in an immediate way. Numbers in sequential order as titles and the lack of any labels next to the works emphasise interaction. However, as already suggested, this event cannot be limited to a work of art viewer interaction. For instance, we should not forget about the very bright white paint with a high reflectance level on the wall that does allow the colour to jump onto the wall in this intensity. Furthermore, we must not forget the specific lighting situation that takes advantage from its position in the building (strong light from the left) supported by a very flat and even artificial light. Clearly, it is *not* the artist alone, who is guiding this visitor, neither is it the architect or the building's layout. Without being able to fully count the present actors in this event—they all came together in this spot and the visitor is moving with them. There is no strict form-function correlation. Many connections, associations, and mediations during the encounter with the visitor become visible. Here is no longer a static whole at work but a lot of diligent helpers who are involved in this specific event. Following the *moving with* shifts the focus from who acts to what acts and we become aware that the whole setting acts together. Here, no actor is in full control and clearly our common hierarchical division of subject and object does not help to take into account what happens in this event of encountering art.

This event develops not in time but with intensities. The encounter with No. 529 increases in speed when the visitor leaves his first position at the bench and starts to move closer and closer, testing different relations between body and piece of art, moving back and forth; this intensity is lost in the next moment as he leaves around the corner; and gains new pace with him coming back. Spacings are driven by their own speeds and intensities. They develop not *in* time and *in* space instead time here is produced in the process, in the event similar to spacing. Leaving an objective space we also leave an objective time and enter different processes which create spacings and timings which can be characterised by intensities (Latour 1997). Furthermore, this account helps understanding how ephemeral spacing is.

Thus, inside the building there is not one homogeneous space, but countless spacings where their own speeds and intensities co-exist.

### 6.3.2 Light and Shadow

We already approached the light as a connective power propagated through uncountable devices, reflective surfaces, the louvre system, etc. that make light move; that make it generous. We have drawn attention to the modality of light that renders visible through its materiality—the *heaviness* of light. However, the observation above furthermore points to another aspect of light: The play of light and shadow.

In my encounter with the visitor, I could not explain the lines in the red areas on the wall and the softness of the yellow zones, but a later hint from the curator seems to offer a solution. Winner reminds me that a sharp amount of daylight enters from the left, while the light incidence from the conservatory is minor. Daylight and artificial light are mixed but the very position of the artwork on the wall in relation to the openings of the building's façade is crucial. The bars in the middle draw a shadow to their right because intense light hits from the left. The light spreads out because it is reflected on the surface of the object, the light bounces back and draws infinite colours and shapes, but at the same time because it bounces back, shadows appear in the original path of its movement. These shadows caught the visitor's attention. Light and dark, natural and artificial light play together with No. 529, and with the visitor. The event of the un-concealment of the lighting has a connecting power just as the multiple reflections do. Light and shadow create depth like the technique of *chiaroscuro*, a painting technique in the Renaissance that gives volume and increases the spatial depth by contrasting light with dark—a technique to give space (Pallasmaa 2012, 50f.). However, my interest is not in a tool for creating illusory effects, but stays with spacing.

The play of light and shadow is a spacing device. Croose Myhill, Education Officer at the Sainsbury Centre, points out that this play of light and shadow is one aspect that counters the stability of the 'historic display' in the Living Area: 'What feels like a very fixed display suddenly becomes actually quite a dynamic display, and the more time you spend in a collection, the more that kind of reveals itself.'<sup>17</sup> There is a speed of light. But light is travelling and moving, dancing and passing through by the mediation of a generous technical system. In contrast to the ephemeral character of the daylight that is speeding up and slowing down with the clouds, the artificial light is subject to a completely different rhythm. It is the light that travels with a constant speed. That is stable. But is it?

In the morning before the Gallery opens, there is the 'cleaning light' (Fig. 6.9), fluorescent lights, rather luminous that shows all dust that accumulated during

---

17 Croose Myhill, in-depth interview.

the previous day on the acrylic glass covers; during opening hours, there is the exhibition light (Fig. 6.10), that changes according to every object that either travels downstairs to rest in the dark or goes on loan and so exposure needs to be adjusted on the object exchanged, but also changes with every light that happens to go out. 'Usually in the morning I come in to check the gallery, to make sure there are no lights that have gone out overnight', Trevor Smith, maintenance electrician at the Sainsbury Centre explains.<sup>18</sup> He does so with the help of a hawker's tray (Fig. 6.11). Smith is also pointing out that the halogen lamps 'get redder and redder and the light output goes down' as they age.<sup>19</sup> Showing me several reddish lamps he explains that they are in the state of experimenting with LED. The savings both in terms of electricity and money, the colour of the light, the decrease in light over time, the lifespan of a bulb, the loss of heat, the possibilities to adjust the existing fittings, all this has a relevance and are underlying concerns. In summary, there is a dynamic inherent to the artificial light that only reveals itself to the knowledgeable viewer. Tracing the light involves both observation and the knowledge of people from inside that allow for the process of light to be unravelled.

Light and shadow travel throughout the building because of its transparency, because it is a monospace. There are no walls that stop the light and its shadow in their movements. In the beginning, it is the intense visual but also acoustic transparency throughout the building that allows me to relate to what is happening on the mezzanine, even if I am not in the exhibition myself all the time. Likewise, I can witness visitors on the mezzanine leaning at the railing and following the hustle and bustle in the school area or the restaurant. Rycroft's office is located underneath the first mezzanine and thus he is looking from his table towards the gallery mezzanine. He points to the blinds on the inside of the glass front of his office that gives him back privacy, '[g]iven that you've basically got people wandering up and down this exhibition space most of the day, it just allows for a bit more privacy if the blind is closed.'<sup>20</sup> The absence of walls as dividing functions and with it areas physically separated from another is one of the key characteristics of this building. On the one hand, these visual references allow for more or less voyeuristic or contemplative observations and, on the other hand, as in my case, lead to active participation, related actions and modes of engagement. But even though the openness of the building allows me to stay in contact with the activities on the mezzanine level while lingering in the adjacent areas there are movements and interactions that I cannot witness: When artworks are being touched and moved.

---

18 Smith, Trevor (Maintenance Electrician, SCVA). Walking interview by Sabine Hansmann. Norwich, 18 May 2017.

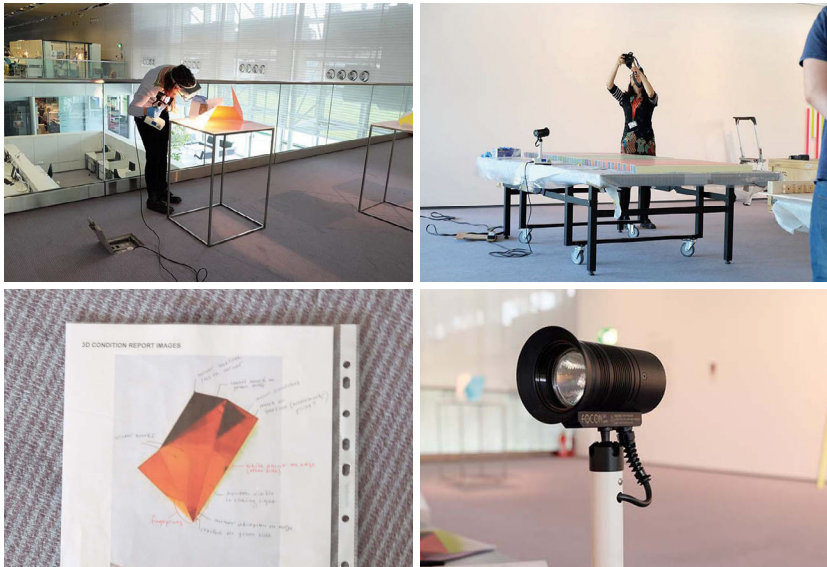
19 Ibid.

20 Rycroft, in-depth interview.

Nobody does this while I am there. Clearly my presence changes behaviour and as such I am part of the spacing as it takes place during my visits.

However, pieces of art are touched and these interactions are traceable. On the Saturday described, a metal stick of the work No. 161, the yellow leaning piece at the end wall of the exhibition is moved. Later I see mounting material on the wall proving that one stick is no longer in its original place. These interactions leave traces: fingerprints, scratches, paint losses, etc. which will be collected at the end of the exhibition. Light in this context becomes a tool for examining and handling the artworks, and marks the starting point of a journey into the agency of the artworks.

## 6.4 Monitoring and Rotating



**Fig. 6.13**

### Third Setting

Date: Monday October 16, 2017; early afternoon

Location: Second mezzanine. The exhibition *Space Light Colour* by Rana Begum.

In the third week of October 2017, I return to the Sainsbury Centre to observe the de-installation of Begum's exhibition *Space Light Colour*. Maria Ledinskaya,

the conservator, is the first person in the exhibition area on the second mezzanine on this Monday morning. She is looking after the well being of the objects, both in the collections and those that are loaned to the Sainsbury Centre externally for exhibitions. She has just started to examine the artworks. Equipped with blue lab gloves and a magnifying headset she is focused on an object in front of her when I arrive. She lifts the object with both hands and turns it around, reaches for the lamp on the ground next to her, turns it on and runs with the light across the surface of the object.

'The colour coating is very sensitive', Ledinskaya explains, and visitors would have touched the works again and again.

She is now standing in front of piece No. 516 moving again slowly with the high intensity lamp in the right hand and a sheet of paper in the left hand around the artwork. Systematically the light drives along the surface of the sculpture. The cone of light glides over the orange finish, from one edge to another, slows down at one spot momentarily and speeds up again. Ledinskaya moves her whole body but particularly her head smoothly with the movement of the light beam along and around the object; she stops, gets a soft microfibre cloth and runs over the white smooth areas of the object. She bends over forward and inspects carefully the surface and compares her findings again and again with the notes on the sheet of paper in her hand.

The condition report is at least two pages for each object in a transparent cover, one with text and one with an annotated image. 'Crack in paint, abrasion, flattened paint area, adhered fibre, minor paint loss, scratch, minor cracking, shiny area' are frequent notes that I can find precisely localised by lines and circles on the image of the object. The second sheet includes a table in which all the data for the object is entered: artist, owner, title, dimension, material, packing, handling, display requirements and condition of the structure and the surface ... she signs this note with today's date in red ink.

Ledinskaya puts the lamp down on the floor. Walks over to the bench in the middle of the exhibition area and picks up her digital camera and returns to No. 516. Again, her body is slowly rotating around the object, this time with the light in one hand and the camera in the other: Taking pictures of all the findings.

She has the impression that there are new marks present on the objects. She needs to go downstairs later and compare the new pictures with the pictures taken on arrival of the objects, Ledinskaya explains. The sculptures were re-

peatedly touched, partly because there were no signs and the room was difficult to monitor.

With the dismantling of the exhibition Ledinskaya starts to collect the traces. She carefully checks and documents the condition of an object when it arrives and before it leaves the Sainsbury Centre. This is integral to the insurance process and they keep a copy of this report for 10 years. Paper, is considered to be more a record document than digital files, which, by their nature, would rarely meet such criteria of 'record-ability'. Furthermore, the quality and details vary and every time a new person looks at a piece, she or he might find new or extra details, Ledinskaya explains and adds that different institutions handle this differently. In the case of the Rana Begum exhibition, she will write a small report, summarise her findings and explain why she thinks this happened, instead of sending all condition reports with the objects. This procedure is based on trust, but that also varies according to the exhibition. With the Begum exhibition it has been in a much riskier environment than they would do normally. The artist, however, wanted the works to be shown without explicit 'do not touch' signage or barriers, as she felt that that would take away from the viewer's experience of her work Ledinskaya then clarifies and adds, that in practice, it turned out to be difficult to protect the artworks.<sup>21</sup>

#### 6.4.1 Condition of Movement

Ledinskaya moves with the light around the artwork, searching for traces of interaction that are left behind on the surfaces. The intensive light renders all differences, all changes in the texture of the surface visible. Still the exhibition is unchanged and Ledinskaya's movement, her inspection, cleaning and documentation, is the pre-condition for the objects to start their movement: From the walls, on the Ping-Pong table (examination of the back side by Ledinskaya), from the table into the wooden boxes softly surrounded by foamed plastic, closing, screws, the boxes line up in a row, travel down from the mezzanine and wait for the courier. There is an amazing world of mediators who accompany these procedures, who guide the technicians ... but for now, let us return to the light.

Work No. 529 could be exhibited on the mezzanine because its materiality is not light sensitive just like most other objects in this show. Begum uses industrial colour that is actually for exterior use, hoping that this extends the lifespan.<sup>22</sup> From a conservation point of view, the mezzanine is a particularly difficult area in the building in terms of light conditions due to its location within proximity of the west end façade and the school conservatory. The glass in this area allows for a lot of light for the restaurant and the school area, areas where people meet, work,

---

21 Ledinskaya, in-depth interview 2.

22 Begum, in-depth interview.

eat and chat. Back in 1978 the mezzanine was also such a place, a bar for post-graduates and staff, the ‘Senior Common Room’—a leisure area. The mezzanine underwent several changes later, each of which created different connections, controversies, interactions and events in the daily life of the Centre.

Hence, the mezzanine was not put in place to be a gallery space and this creates a specific world of practicalities today, of what the light does to the artworks. Particularly in following the light we can understand how the building’s shell, its openings and materiality is present in spacing. The building’s shell in connection to light prohibits certain exhibitions on the second mezzanine unless other actors are included. ‘[S]o we would look to either show objects that were not vulnerable to light damage, or try and build walls in such a way that protected vulnerable objects, [...] in some cases we would put up a cover over a case, so when there are no visitors it’s protected completely. [...] [W]e cannot control the brightness of the light at any given moment but we can tell you how much exposure it had and then try to work backwards from that, put covers on things or you could limit the duration of the exhibition.’<sup>23</sup> Light damage is cumulative and leads to both loss of colour and strength of the material. The classification of the objects from ‘highly responsive’ (silk) to ‘non responsive’ (most metals, stone, ceramic) is not always easy due to material mixtures (Cuttle 2007). Once classified a decision needs to be made on how long an object should be preserved before a schedule can be made. This brings the curator and the museum management together. The idea is to have light quotas for every object in the collection but this is part of the on-going light management survey, which Ledinskaya bases on guidelines from the Victoria and Albert Museum in London (V&A). The classification of the objects is only one step, surveying the site (the proportion of electrical and natural light, the movement and hot spots of light in the building) is another. Once finished this survey will guide the objects in their movements. When they must go to the storage to rest in the dark, when they are allowed to return, where they should be shown (facing north), and how much and what kind of artificial light should rest on them. Here is another gathering of actors: Light, building, curators, objects and materials, V&A guidelines and object reports; they all work together to create the future trajectory of each object. And with this comes the possibility for each of them to contribute to specific events, to meet with visitors, or to stay hidden in the dark.

#### 6.4.2 The Controversy of Light

Light that makes us see, allows us to enjoy the art, it connects us and guides us, it makes the colours glow and jump—it is fundamental to our experience, essential to the pleasure and information in a museum. But it causes damages to nearly all forms of art media. That is a principal problem that art museums have. In the case

---

<sup>23</sup> Ledinskaya, in-depth interview 1.



of the Sainsbury Centre, it is not only the visitor experience versus preservation of the object, but also other actors that are involved in this controversy over light. Light is *in the making* and with the experimentation during Summer 2017 this controversy has gained new pace, and the tempo feeds on the past.

It is said that Robert and Lisa Sainsbury favoured natural light and appreciated sun strokes on paintings (Rybczynski 2011, 141). But when the building opened the concept of a light-permeable building that houses art was already controversially discussed and new recommendations on lighting levels published at that time were much lower than what could be reached in the Living Area (Thomson 1978; Boys 1978). This contradiction has driven many decisions until today and is at the centre of much of what we have discussed in this chapter. Sexton puts this dilemma in the following way:

I think there's a fundamental problem. A lot of the collection has works on paper in the Living Area, and I think if you look at lux restrictions in museums for works on paper, it's almost counter to having any daylight at all in the space. When the building was designed, the patrons [...] were more concerned about how people enjoyed art, rather than saying you need to be at a certain temperature, at a certain humidity, or a certain lux level, and I think the whole package: the space, the relationship with daylight in the space, the relationship of the display to the space and of the objects to the display, if you upset any of those parameters and put them in the context of a museum, a very strict museum environment, you really change dramatically the experience. And to them I think the experience was much more important than the preservation of the objects.<sup>24</sup>

However, Sexton adds that he does not wish 'to give the impression that the Sainsburys didn't care. I knew that when they had the collections in their home, when they would leave their home they would pull all the curtains closed and blackout the room.'<sup>25</sup> It is part of the narrative of the Sainsbury Centre, the story that is frequently re-told during every guided tour and in all publications, that the domestic setting of the Sainsbury's home at 5 Smith Square in London informed the design of the building, which is reflected in the naming 'Living Area' (Powell 2010). And there is a strong desire to maintain the 'original' building and to affirm the legacy of the patrons (see Chapter 4).

The decision to leave the screen lights switched off during Summer 2017, which was due to conservatory concerns, turns out to be very contentious, as it is considered to compromise the 'design intent'. Joe Geitner, the project manager at

---

24 Sexton and Geitner, in-depth interview.

25 Ibid.

Sexton Associates, is, together with one colleague, more or less in the Centre every week to make adjustments to the lighting in the Living Area. He is tasked with fixing the light problems:

The other problem I thought with that approach is because you turn off the light on the screens, you lose the reflected light on the floor, it's harder to navigate the space. And then the works [...] have a halo of light around them, so the light becomes really obvious, which is unfortunate, because you lose the blending between the spotlighting and the lighting of the vertical surfaces. So we disagreed [with that approach], and we're working with them to maintain the design intent but help them reduce the amount of light that hits the works, as they see it, in the summertime.<sup>26</sup>

Also the curator Winner admits, 'It becomes very atmospheric and very moody'; he adds that it is 'very unpopular with our visitors, I think.'<sup>27</sup> The problem is provisionally solved in September 2017 when the lights on the screens are turned on again. It is winter term.

Ledinskaya explains that it is difficult for her to negotiate with the light in the museum because the damages are so gradual, but she just received an email with information about the considerable financial savings made by reducing electric light during the last four months. She adds, she hopes that Joe Geitner will come up with a good solution that is both energy efficient and creates less light exposure.<sup>28</sup>

Ledinskaya then addresses a very important aspect: some actors are more pressing and noisier than others. Saving energy and thus saving money acts in her favour, in favour of the art, while the gradual damage remains irrevocable but mainly invisible and therefore more difficult for their spokeswoman to argue.

Light exists within a contested space and brings many different actors together: the lightning designer, curators and conservators, the living room in 5 Smith Square, the spokesmen and women of the past and objects of the collection, the visitors, the material responsiveness classifications and the mappings of light hot-spots. Light is holding all this together and creates new associations (e.g. the conservator and energy consumption). The light and with it the building are in the process of making, of experimentation and controversy. Light as an ingredient of spacing connects a wide variety of actors. Often overseen and taken for granted, it turns out there actually is a huge amount of work that is necessary to let the light travel and participate in spacings in the Sainsbury Centre.

---

26 Geitner in: Sexton and Geiter, in-depth interview.

27 Winner, in-depth interview 2.

28 Ledinskaya, in-depth interview 2.

## 6.5

### Conclusion: Spacing Devices

Spacing requires work: Work that we can learn about when following the permanent actors in their long-term engagement in working-with (Chapter 4). But this work also becomes visible when asking questions like ‘What is doing the light?’ that shifts our attention towards the many nonhumans involved in spacing.

Light is a classic topic in architecture. ‘Architecture is the masterful, correct and magnificent play of volumes brought together in light. Our eyes were made for seeing forms in light’, as Le Corbusier famously wrote in *Vers une architecture* (1923, here quoted after the English translation 2007,102). Furthermore, light serves in the phenomenological tradition as an effect to create atmospheres for bodily, sensual experiences of space (Böhme 2017, particularly part IV).<sup>29</sup> The account into the world of light in architecture with this chapter, however, was very different. It is not the aesthetic quality, the masterly shaping of forms that become alive in the play of light and shadow and the sensorial appreciation of it that was of interest, rather we traced how light is done and the doing of light.

Light has a connecting power. In experiences, in controversies, in happenings and events it is connecting every day countless actors. With the modality of lighting there is the technology, the ‘faire-faire’ of light (Latour, 1999a, 21), that is made visible through countless technological devices and that can travel because of the transparency of the glass and the building as a whole. There is the rhythm and the course of the natural light and the rhythms of the artificial light (Monday is a dark day), there is the speed of the light and the dynamic of the shadow and the play of these together. There is the institution that wants to be faithful to a legacy and also wants their visitors to enjoy as well as presenting the art in a well-lit environment. There is the conservator who rests the objects downstairs in the dark. There are the objects that deteriorate invisibly and the costs that are not to be underestimated; there are silent and invisible actors as well as manifest and omnipresent ones. Space is being made on a daily basis with all this stuff, with all these humans and nonhumans.

In all of this there are countless materials and objects involved and as such this chapter particularly turned our attention to the material world of the Sainsbury Centre. Not that this world would have been less present in the last two chapters and of course the world of light is also a socio-technical one, but light in its speed and generosity renders this chapter particularly rich in materiality. We collected some key actors like the blackout blinds, the louvre system and the halogen

---

29 See also Pallasmaa on the loss of architectural masters in times that treat light as ‘mere quantitative matter’ (2012, 51).

lamps, but also the building's shell with its distinct openings appeared again and again throughout the chapter. We became aware that none of these is doing the light, not the halogen lamps and not the openings in the building's shell, but that the light is rendered visible out of a complex network that mixes and layers, monitors and maps light.

The monospace allows the light to travel and we traced this network of light, how it connects a student with the greenery outside by mediation of the shiny white wall or how it facilitates and creates the specific event of encounter between a visitor and piece no. 529. By following the light, we witness the doing of the building in specific spacings in which various actors are involved. The building is not acting on its own but is nurtured by its parts and connected to many other actors in its doing. Understanding the ways in which a building shares agency is essential to grasp its contribution to spacing. Here, we understand particularly well, that in spacing, in courses of action, we cannot draw lines between architecture and interior design. Actors act and they are made to act (Mol 2010). It is not one building that acts in one way. The building facilitates, allows and hinders spacings on the second mezzanine differently than in the East End Gallery. What is possible with the building in one area differs from another; this is due to its specific shape and layout, but also to other actors it connects with. The event with no. 529 was only possible due to the very specific weaving together of actors at this place. Not in time and in space, but in the process of this joined spacing.

We have taken three different paths to explore the building 'in practice', to witness the spacing in and with the Sainsbury Centre. First, we entered the world of the building by taking a walk with Winner and focused on how humans and nonhumans share agency in re-thinking, re-shaping and re-transforming the material world as much as courses of action and movements. We became aware that in spacing we face both moments of stability and moment of negotiations. Secondly, turning to the experiences of people who only engage temporarily with the Sainsbury Centre, we witnessed the multiplicity of both experience and the coexistence of multiple spacings, which do not emerge out of simple causal relations. And thirdly, by following the light we encountered the work of the countless spacing devices that come together and connect, guide, re-direct and facilitate mundane practice as much as any specific event. With the next chapter we draw these different accounts together in more detail and discuss the implications spacing has for our understanding of the architectural relation.

## 7

# A New Dynamism in Architecture

---

The monospace is a type of building, which due to its structural openness suggests a high level of flexibility and adaptability in use and thus emphasises the processual nature of architecture. Without a traditional separation of specific functions into separated rooms, the monospace questions 'a strictly constructive idea of architecture' (Fontenas 1998, 9). I therefore chose the monospace as a particularly interesting starting point in order to challenge the predominant static and passive understanding of buildings (Chapter 1). I argued that an absolutist-substantialist understanding of space particularly with this type of building obstructs the ability to grasp the complex and processual reality of architecture. Turning to spacing and following the shared agency of humans and nonhumans in courses of action with the help of ANT, promised to trace the monospace in its multiple dimensions and in its mutual entanglements (Chapter 2). This study, thus, approached the question of temporality in architecture on two levels: On the one hand through the focus on a monospace building and on the other hand through the chosen methodology of ANT.

Concerned with the Sainsbury Centre for Visual Arts, this work then first explored this building in terms of its architectural plans and the existing literature (Chapter 3). Describing the Sainsbury Centre as a building *in space*, it is located at a singular spot at the very end of the campus of UEA in Norwich. Describing it *in time*, it has a chronological biography, which has been told by Witold Rybczynski (2011). The building reproduced through iconic images and dominant narratives in books and magazines has been frozen in its representation countless times and tied to linear spatial and temporal trajectories.

Turning to the building in practice, we then left a space as place and turned to a space that cannot be separated from time. Consequently, we also left the idea of centrality and singularity and encountered the building as a field of possibilities. We learned how the building is a fully blown actor in working-with, in processes of re-thinking and re-designing material settings and thus in shaping and changing ingredients for spacing (Chapter 4). Furthermore, we witnessed how it participates, enhances and changes courses of action and movements in

spacing. We traced how the building is entangled with humans in daily practices and how multiple experiences can co-exist with the building (Chapter 5). We lost sight of the old or new building, the inner and outer, and discovered the numerous material and immaterial devices that contribute to spacing when following light (Chapter 6).

However, in the course of the empirical study a particular ambiguity in relation to temporality became apparent. The idea of flexibility and adaptability also adhere to the Sainsbury Centre (Chapter 3). Since its opening in 1978, however, the Sainsbury Centre has stayed more or less the same and the Living Area is considered a ‘historic display’ today.<sup>1</sup> Smaller changes of caterers in the restaurant and café, university political restructuring of the teaching programme and administration, the growth of the research facility and the move out of the building of the senior commons club, aside, the forms of use of the building have remained more or less constant ever since. There have been changes, the trees in the entrance area have disappeared, the shop expanded and changed sites, temporary exhibitions moved in and out, office boxes have been set up on the first mezzanine and a lecture room was installed etc., but on the whole, there is a great degree of continuity for a building that would *potentially* make change easy. Yet, potentials are part of a determinist architectural thinking. ‘Potentiality is the realisation ‘in time’ of what was already there *in potentia*. Time unfolds determinations, but nothing really happens [...]’ (Latour 1997, 185; original emphasis) Potentialities are planned by architects and are inscribed into buildings, but whether they are fulfilled by the objects, and whether people treat objects accordingly or if new and other ways to relate emerge is a whole different story (on inscription and de-description see Chapter 4). This study as it is concerned with a realist account into architectural space, set out to explore these other stories. Tracing how people and building relate, it was not about linear developments but the mundane practices and entanglements of people and building in reality witnessing how spacing takes place.

Surprisingly the architect himself amongst others contradicts the idea of change for this building. Developing a façade that is modular, and can be exchanged easily, creating a vast interior that could be a playground for experiments, we learn today nothing can be changed in terms of material setting if it is to be permanent, and especially not the Living Area (Chapter 4). ‘The single space—the integrity of that is very important’,<sup>2</sup> the director emphasises. Buildings have specific trajectories that emerge in negotiations. And while we face a 40-year-old building which still ‘looks the same, apart from the different cladding, and those two overhangs’,<sup>3</sup> nevertheless this building is always on the move,

---

1 Croose Myhill, in-depth interview.

2 Greenhalgh, in-depth interview.

3 Evans, in-depth interview.

always changing, never static, never the same. To be able to witness this vivid life of the building, however, we had to move inside and leave the regime of potentiality behind. With ANT we understood that flexibility is not a property of a building but of an association of humans and nonhumans, as much as stability is. A monospace is not flexible as such, but it requires work to make space flexible,—work that is always hybrid, human-nonhuman.

Turning to the process with the building, we encountered the many ‘other entities’ that are necessary to produce space (Latour 1997, 186). This is a space of possibilities; this is why spacing gives us a very different insight into the Sainsbury Centre. I want to highlight the difference between potentialities as inscribed and possibilities as emerging since it provides for a significantly distinctive understanding when turning to architecture.<sup>4</sup> Following the latter, we encountered a contingent world of entanglements, of negotiations and contradictions and learned the differences both humans and nonhumans can make. Here, we left a clear and well-structured world in terms of space and time behind and confronted the many times and spaces that the building weaves together.

In the following, we re-collect and put together what we have been able to witness at the Sainsbury Centre over the past three chapters; firstly the specific insights we gained regarding spacing and subsequently regarding the roles of people and building. With spacing some existing predominant ideas in the field of architecture are called into question. What allows us to witness and acknowledge thus far overlooked or unheard actors, simultaneously questions the dominant role played by previous well-established ones. Hereafter, I will make some concluding considerations regarding the methodological approach before opening up perspectives for further research.

## 7.1

### Spacing the Monospace

We embarked on this study with a paradox. In examining space in the field of architecture, this book combined two distinct concepts: The first had roots in a traditional architectural understanding of space and feeds the self-understanding and field of obligation of the discipline of architecture (Chapter 1). The typology of monospace relies on this concept and represents its archetype. Here, space can be singular, controlled by a designer’s hand, shaped by walls and completed once construction has ended. The second builds on a relational and processual understanding of space and

---

4 Latour (1997) opposes *potentiality* with *virtuality* following the definition of Gilles Deleuze and Isabelle Stengers. Since the philosophical discourse about the difference between virtuality and possibility is of less interest here I use the more common term of possibility.

takes a nondeterministic stance. Spacing gives preference neither to a subjective nor an objective space but follows the processes in which both humans and nonhumans entangle (Latour 1997).

Following spacing allows us to analyse the monospace, not as a static container space, and as such *not* as a space *in* which many things and activities happen, but as a space in its specific capacity to connect and organise and in this way in the process of opening and closing possibilities. Entering the world of spacing at the Sainsbury Centre we become aware that spacing is work—work that is done by humans and work that is done by nonhumans (*ibid.*). This work does not stop once the building is erected, but forms a dense network of action that has no end. We can distinguish two different types of work when facing architecture: Firstly, the work that is concerned with ingredients for spacing. This work is traditionally done by architects, planners, and engineers and in our case also by curators, conservators and technicians together with many nonhumans. Secondly, the work that takes place in the act of spacing itself. Here many different actors, human and non-human, come together to produce, shape and shift a specific course of action.

Re-thinking and re-arranging the material setting or courses of action and movements is a work that is concerned with the elements that make up spacing. We touched in all three empirical chapters on this kind of work. The networks which are concerned with getting people through the doors (Chapter 5.2) or the networks of light (Chapter 6) that show us how multiple actors of different qualities come together and work towards a smooth and stable and thus constant or repeatable course of action. When gaps, problems or new demands occur, a destabilisation takes place. New actors are added or an experimentation as in the case of light starts that tries aligning mediators towards stability. Walking with the Head of Collections and Senior Curator throughout the building and listening to his colleagues we became particularly aware of work that is concerned with ingredients for spacing (Chapter 4). What at first glance looks like a human-centred field of activity turned out to be a closely connected process with the building, in which we cannot necessarily figure out who caused who to do what in how far. It is a working-with that becomes visible; previously explored by studies into the making of buildings (Loukissas 2012; Houdart and Minato 2009; Yaneva, 2009a, 2009b). Decisions here are not linear and not developed under full control of humans. Instead we witness how the building as an actor itself and all the materials and objects are present when it comes to making decisions about changing courses of action and thus modifications of networks for spacing as with the installation of the underground Exhibition Suite for example (Chapter 4).

The second type of work happens to take place in the act of spacing. Here different actors come together and create space. This space is neither objective nor subjective, but emerges out of entanglements in interaction. By tracing specific experiences and events, by following humans and nonhumans and their joint practices, we were able to enter spacing without asking who or what acts upon who or what. This



allowed tracing the work that nonhumans do and understanding how monospace connects differently.

These two types of work are analytically separable; however, they are intertwined. On the one hand, working-with ingredients for spacing is a course of action and we can approach it as spacing itself. On the other, the ingredients fold courses of action to become then actors in new spacings. This makes the situation sometimes confusing and requires clarification as to which aspect should be considered. Following these two types of work we gained a detailed understanding of the process of spacing in the field of architecture, which extends the moment of spatial creation beyond the completion of building. In the following I would like to summarise six distinct characteristics of spacing that stand out in dialogue between the empirical observations and the existing ANT-literature as explored in the previous chapters. However, these characteristics should not be misunderstood as a rigid system but rather as a fluid field, which will change with each new account of spacing.

*Firstly, spacing is about connectivity.* Spacing happens in the interaction of different humans and nonhumans. It emerges out of connectivity in courses of action, in negotiation, in controversies, in experiences. We tend to take all the work that nonhumans do for granted, yet, particularly when problems occur or things break down we become aware of the work of (thus far invisible) actors (Latour 2005). While connectivity with regard to built space is traditionally understood as of a linear relationship (Chapter 1), in spacing it is mutual entanglements we encounter. Thus, approaching the monospace through spacing, we do not understand how it acts upon people or how it determines certain courses of action but we gain a detailed view into the different ways a building can share agency and how we can follow the doing in common. We learned that the monospace makes it easy to guide groups of people around or difficult to project the voice to larger groups (Chapter 4.4), we witnessed how it contributes to the event of specific encounters with pieces of art (Chapter 6.3) or how it allows light to be 'generous' (Chapter 6.2). Yet, in all these events it is only sometimes the building as a whole, as a singular object, but more often specific ingredients, elements, materials, objects, rhythms—thus spacing devices—that become visible.

*Secondly, spacing is about decentralisation.* Asking who is doing the work of spacing we face countless actors, both actors who are present and actors who have left the site or only show up every now and then. While in traditional architectural space that is shaped and enclosed by the presence of walls, in spacing we confront the presence of many actors *in absentia*.<sup>5</sup> If we understand actions as a knot of

---

5 See Latour where he remarks that interactions are not *isotopic*, *synchronic* and *synoptic* (Latour 2005, 200f.).

agencies which makes a difference, which re-directs or opens up new possibilities (Chapter 2.3), then turning to spacing we confront many actors who contribute to spacing while not being present. The Sainsbury Centre was put in place 40 years ago. Ambling in its field of art today, chatting in the cafe or reading a book in the school area is possible because countless silent mediations allow for it, because the building holds them together. Turning to the experiences in spacing we witness the work that the nonhumans do when facing daily practices. We can follow how the circular shop works as an anchor giving orientation, how the spiral staircase allows for an overview of the interior from its pinnacle and for a safe descent, and how the setting of the Living Area mobilises, speeds people up, slows them down, and guides them around corners to let them explore the art (Chapter 5). Unravelling the knots of these daily courses of action leads in countless directions. Engaging with a painting by Francis Bacon in the Sainsbury Centre is, thus, not an interaction *in space and in time* but an event of connecting with different actors, times and spaces (Chapter 5.4; Latour 1997). The concepts of inscription and delegation are key to understand that spacing does not only happen in the local presence of these objects and thus does not only depend on the materiality put in place (Chapter 4.4). The humans, the architects, the planners, the craftsmen, the patrons, who put them in place, who placed them with the help of countless diligent helpers, still make a difference and as such they are part of the agency. They re-direct and open up new possibilities; they contribute. Following the connections of any spacing thus leads not only along the networks to many different devices in the building but also to many other places and times.

*Thirdly, spacing is about negotiation.* Approaching spacing we do not only face stability and continuity, which are traditionally attributed to materiality in architecture but we always face negotiations about the courses of action that are possible with it. While the setting of the Living Area carries a script of being 'anti-museum', and while many humans and nonhumans work towards keeping this setting stable and thus to make certain courses of action the same and durable throughout time, spacing allows witnessing adjustments (Chapter 4.4). Enacting scripts in practices today, they are not simply extracted but negotiated (Akrich 1992; Murdoch 1998). We saw that practices of communicating art change and thus that difference occurs in how people and works of art interact. Hence, new spaces emerge while the material setting stays the same. But this also suggests that buildings must not be understood as technical objects in the sense of a clearly defined interface for use; they are manifold in their possibilities for action (Chapter 5.5; Guggenheim 2009). Particularly, monospace buildings seem to offer due to their structural indeterminacy a high level of openness for negotiation. This openness, however, also seems to create a particularly high degree of complexity in negotiation, because when activities touch e.g. on aspects like light, acoustics or climate this affects easily the whole monospace building, its elements and activities. We

saw this high complexity through connectivity in the case of the decision to set up an exhibition suite in the underground instead of in the monospace (Chapter 4.2), or in the long-term study on the change of the lighting situation (Chapter 6). In these decision-making processes, the monospace, the different materials, but also the individual works of art, the insurances schemes, the lenders and the funders, etc. are present. The building connects these multiple actors in negotiations, in controversies and spacing allows us to unravel them. And since negotiation is thus a specific form of connectivity, as explored earlier, this collection of characteristics overlaps and is fluid.

*Fourthly, spacing is about intensities.* Spacing is not homogenous but develops with different intensities and speeds (Latour 1997). Spacing is dynamic. Time joins space. Following a visitor in the act of moving with a piece of art we witnessed how different actors, the artist, the building's spatial layout, the white paint and the colours and different lights work together towards the event of encountering the art (Chapter 6.3). Events carry speeds and intensities like negotiations do. We traced how the controversy of light gained new pace with the blackout blinds breaking down and with the conservator changing lighting policies (Chapter 6). All the objects have their own timings and ways of existence, which develop not in linear time and space but with intensities.

*Fifthly, spacing is about multiplicity.* The connectivity in spacing, since it brings actors of different material qualities together, which all have their own timings and ways of existence, is not only connecting actors but is opening new possibilities in these connections. Thus, actors arrange each other; they exist in relation to each other (Chapter 2.3). We witnessed how the monospace opens and closes possibilities for each of them. Spacing is a relational process in which each actor can be many since actors gain their capacity to act in networks. We saw how the glass, the louvre system and the different materials allow the light to bounce and jump and move horizontally and vertically throughout the building and thus to be a 'generous' actor (Chapter 6.2). Furthermore, we understood that an object, like the display case in the East End Gallery, depending on practice could promote and enhance courses of action and hinder others at the same time (Chapter 4.3). Thus, depending on practice the case forces us to face a different reality of the case (Mol 2002). Objects like people exist in multiple realities. Spacing brings together actors of all types, material qualities, from different times and places, humans and nonhumans. Opening the black box of the building, moving inside and following spacing we witnessed how they all coexist. A building in experience, in perception, in practice is always changing and thus never stable and singular. Turning to the building in practice we entered by following spacing the multiple dimensions of the Sainsbury Centre, yet we will never fully grasp them. A realist account on space faces multiplicity.

*Sixthly, spacing is about uncertainty.* Entering the concerns with specific spacing devices, we witnessed what it costs to control space, to make courses of action predictable, repeatable and thus stable. Yet, turning to reality and following the working-with or specific experiences we became likewise aware of the uncertainties. Both people and objects can act in unpredictable ways. Both built up surprising connections that lead to unique, unrepeatable events and new courses of action and thus new spacings. Following people in their trajectories we saw that their journeys with the material world are not linear, but that gaps occur leading to hesitation when mediations fail, when adequate knowledge or other stabilising actors are missing (Chapter 5.2). We saw that technical objects break down, like the blackout blind and lead to 'darkness' in the Living Area (Chapter 6), furthermore we saw that objects build up surprising connections in which they can gain their own independence and resist. The connection of the heavy case and goods lift is such a situation in which movements of people and objects are re-directed throughout the building as long as the lift is out of service so long as the case is on top of it and as long as adequate tools (and thus actors) are missing to move the (depending on practice) unstable box (Chapter 4.3). Actors gain their capacity to act in relation to other actors and since not one single actor is in control the process of spacing carries uncertainty.

Following spacing as it happens in experience, in practices and events, there can be no such thing as a singular space, a monospace. Thus, studying a monospace building with spacing creates a specific tension between the singular and the multiple. That said, it turns out that the seemingly abstract and formal definition of monospace can exist alongside the multiple spatial courses of action. Spacing incorporates the agency of the building; its (formal) properties are not abstract, not outside but part of its doing. Monospace connects differently and thus it is one dimension of the multiple dimensions of the building. We can understand this when focusing on the far-reaching consequences changes tend to have. For example, changes such as the network of light, climate and acoustics that spread through the whole building without being stopped or separated by walls into smaller groups. The monospace due to its high level of connectivity in this sense tends to make it difficult to change the doing of a network and tricky to control in change, as we saw with the issue of light (Chapter 6). Here there is the orientation of the building towards the sun, the openings and the layers of the light filters to consider, which are just as present in the negotiations as specific materials of works of art, day-, lighting- and art-rotation-cycles or the conservator. The monospace gives them all presence and connects them in specific way. The monospace is present when it comes to rethinking possibilities and it suggests certain solutions and hinders or impedes others. In paying close attention to the multiverse that emerges out of spacing, we can understand the building from inside out,

from within its networks. This provides a different and nuanced understanding of architecture's relationships. Not a static container space but its earthly way of allowing, hindering, and fostering certain events through which its specific dependencies and possibilities occur. Thus, approaching the typology of monospace through spacing we witnessed the 'thingly' nature of a specific monospace in use and its constant mode of becoming.

Before moving on to how spacing helps re-thinking architecture's relations, I would like to touch on the use of the term space in relation to spacing. Space as this study claimed can never be singular. Yet, I would like to suggest that it is sometimes a useful way of black-boxing the complex and processual reality that every space is made of. After unravelling and accounting for the work in the process of spacing in a specific network, as for example in the Living Area, this box can be closed again by speaking of the space of the Living Area. Now that there is a clear understanding that this is not a space that is contained in the Living Area but a space of connectivity and negotiation, that is multiple and complex, and only after a huge amount of work can be brought under control, this seems useful. That said, such use must be taken with caution, since it can easily seduce one into rendering static what is a reality in motion.

## 7.2

### The Building as an Actor

While buildings are traditionally understood to be stable enclosures that contain space, with the help of spacing, we gained a different understanding. Space here is nothing contained, but something that emerges in relations, in networks. If the shell no longer contains space in the sense of an absolutist-substantialist spatial understanding then it is primarily no longer a separating one but one that connects (Yaneva 2010), mediating between inside and outside. It no longer cuts off and encapsulates the one space from an absolute space in a box instead the shell becomes porous, a filter that is actively 'enabling, impeding and even changing the speed of the free-floating actors, data and resources, links and opinions, which are all in orbit, in a network, and never *within* static enclosures [...]' (Latour and Yaneva 2008, 87; original emphasis) With spacing we gain a different understanding for what a building is by what it does and in this it differs from other practice oriented spatial ideas (e.g. Löw 2001).

Encountering the building we do not move *in* time and *in* space but rather with a multiplicity of actors that have their own timings, spacings, goals and ways of being, however, they are connected in a specific way by the building (Yaneva 2010). The building is weaving them all together. As such we can understand it as a specific place. Not as a specific place *in* space (which again would presume a

pre-existing space that is a kind of neutral condition in which the object is situated), however, in its activity of *placemaking*. It is the act of connecting interactions of different times and spaces that is creating the notion of place here (Latour 1997). The building is thus weaving together its very own entanglement of ‘space-time-actants’ (ibid. 181).

When the curator Winner notes ‘We are trying to make the building do things that it doesn’t want to do’ this particularly renders the building as actor visible.<sup>6</sup> With Winner, we traced the specific doing of the building in terms of housing art. Art objects do not collect in an empty space but are situated in the specific network of the building. This network as it concerns the upper part, the monospace, for example does not allow for stable climate as required by some insurance schemes today and thus impedes the prospects of major art loans to the Sainsbury Centre (Chapter 4). This inquiry shows that exhibiting art, and especially in the rapid cycles of changing exhibitions, is an intense working *with* the building that renders visible the building as a whole as well as, in the next moment, the many actors that it necessarily assembles. Here it is not helpful to distinguish between building and interior design, between lighting and furnishing since it becomes apparent that particularly in a museum setting everything works together to produce a specific condition for spacings (particularly Chapter 6). Spacing dissolves the line between inside and outside. Furthermore, it dissolves traditional distinctions as existing in planning. The building’s shell, the automatic doors and air curtain, the covers over the artworks, in some cases silica gel, work together to maintain a constant temperature and humidity for fragile pieces of art (Chapter 4). Approaching the climate, the whole world of the monospace is present. Architecture here concerns the modulation of flows, which do not end once passed the building’s shell. The building shares agency in spacing with humans, objects, materials, rules, climate, etc. It shares agency in the daily movements of people and objects; it shares agency in practices and it shares agency in the grand projects when material transformations take place as with the underground Exhibition Suite (Chapter 4). With this inquiry then we witnessed that ANT is particularly helpful in unravelling this kind of material rich world in flux as it is inherent in museum practice and thus provides for a unique understanding of the latter. Moving into the building and following spacing we witnessed complex realities out of which the museum space emerges.

Spacing thus offers a different view on architecture. The look from inside out leaves the birds eye view behind and explores the building little by little. Here we lost sight of abstract concepts, of stylistic or historic attributions as collected in Chapter 3, and faced multiple practices, events and experiences. Turning away from space as contained in buildings, buildings do not exist outside daily life, but

---

6 Winner, walking interview.

become part of social practice. Social life thus does not happen *in* buildings but *with* buildings (Yaneva 2009c, 2017). The building is part of the flux and it is never finished. As Stewart Brand noted 'A building is something you start.' (Brand 1994, 188) Understanding buildings as unfinished projects acknowledges the building in its entire lifespan. They have biographies and in the course of their life they participate in a sheer endless variety of spacings. This long lifespan is not to be overlooked for architects and as such spacing challenges the idea of the architectural object, which is shaped by designer-architects and completed with the end of construction.

### 7.3

## The Disappearance of the User

Spacing not only draws our attention toward the many neglected nonhumans, it also gives voice to often-overlooked people in the field of architecture. This may be a surprising aspect. Spacing enhances the 'user' in architecture, however it also renders the understanding of a homogeneous 'public' in the museum setting more diverse. Turning to experiences we leave an abstract and predictable user behind and acknowledge the multiplicity of the experience of humans and their engagement with the world of the building. The people working, visiting and dwelling with buildings are to a certain extent disregarded within architectural discourse and production (Hill 2003). Furthermore the museum visitors are also, notwithstanding a shift, 'a relatively homogeneous and rather passive mass' (Macdonald 2006, 8). Turning to spacing we see manifold things, a world rich in materials and objects, however, we also see manifold people, creative, unpredictable and sometimes fragile human beings. Thus, neither nonhumans nor humans are predictable in spacing. Turning to spacing provides detailed insights and contributes 'to see[ing] how living with the world is always to engage in the practice of drawing things together differently' (Jacobs and Merriman 2011, 216). As such spacing allows us to show people beyond the categories of use and function.

We saw that the 'user' can become an expert when working with the building, which emancipates them for example to take on the role of the client in negotiation with funders and architects (Chapter 4.2), or how they circumnavigate rigid spatial settings and introduce new practices that open up new spaces in case of the Living Area (Chapter 4.4). Thus, we face creative and nuanced human beings, in their experiences with the building, particularly with the museum setting. We witness human beings who attune to the setting differently. Those who are receptive to exploring the Living Area, to walking with the objects, and others who feel compelled by the very setting to look at things that they do not want to see (Chapter 5). We learn about things that happen to people with the building

like getting lost and walking to the wrong door, but also about being physically well connected to the staircases and flowing fluidly past the art display, as well as both the joy and frustration that can emerge out of these connections. We met people who have favourite places and rituals that they practice with the building (Chapter 5.4), and people who become immersed into the event of viewing a piece of art (Chapter 6.3). We followed people and learned about their ways of working with the building (Chapter 4). Thus, we faced many different experiences, which co-exist. There is not one way of experiencing the building and not one way of encountering the art. And while changing material settings and practices can enrich perception and foster new encounters, the stability of the Living Area, we learned, allows people to return and to explore its dynamics in stability (Chapter 6.3). As such stability can likewise open heterogeneity, since heterogeneity here emerges out of the relation of object and human (Hetherington 1999).

All these people are individual and gain a voice: in observations, in interviews, in sketching, in courses of action. Approaching architecture through spacing the non-architects become experts themselves. Here we did not witness an overwriting of the original plan of the architect as other authors observed (Guggenheim 2010; Brand 1994; Gieryn 2002) since in this specific case the architect never left the building. In that sense Foster's never gave up authority over the permanent spatial arrangement (which is of course again a shared authority with many other actors in the making). Nevertheless, they do not have sovereignty over space. Thus, we can understand with the Sainsbury Centre even better spacing as a constant re-designing of space that pushes the boundaries of the traditional focus of architecture. It pays attention to small details, the changing of the lighting situation, the introduction of new courses of practice, the work of holding things together. Here we witness the heterogeneity of space—spacing is never the same; it is an ongoing work that creates complex authorships.

## 7.4

### Architects Amongst Many Experts

The Sainsbury Centre became listed amongst other things for its 'in-built flexibility' (Historic England 2017). Yet, reality shows, that what a building is and what it does, if it allows for great flexibility or not is a result of the work of many (Chapter 4). Flexible space (like stable space) develops out of the complex entanglements of humans and nonhumans. Spacing challenges the idea of an autonomous architectural design.

Previous ethnographic studies have shown that buildings emerge out of collective actions during the design process and that the idea of an autonomous architect must be considered a myth (Cuff 1991; Yaneva 2009a, 2009b; Houdart and Minato 2009). Spacing contributes to a further dispersion of authorship *in* space.



Neither can architects determine the behaviour of future people entangling with a building nor can they fully control the doing of the ingredients of spacing they put in place. Spacing does not follow linear trajectories. This gives some actors like the architect a less prominent or powerful position, while other previously overlooked or little noticed actors gain in visibility.

For architecture as a space designing discipline with a focus on the architectural object (Awan, Schneider, and Till 2011; Chapter 1), spacing thus has far-reaching consequences. When buildings have so far been characterised by solid and stable shells and have erected boundaries, thereby separating an interior from an exterior, this has been accompanied by clear distinctions. With spacing these material borders no longer seem stable but act as mediators between inside and outside, as actors in negotiation, in experience, in perception and processes. The shell no longer creates a closed object but is itself of many individual parts, a group of actors in networks. Here the clear and singular affiliations of the abstract object dissolve and its multiplicity comes to the fore. Whether the shell is a wall that cannot be penetrated, as it happens to visitors prior to the opening of the building (see Chapter 5) or whether it presents itself in elements in working-with with gaps under its doors allowing vermin to circulate (see Chapter 4) is not due to different perspectives but to different practices. Turning to practice we approached the multiplicity of the building in practice and faced a world that is not defined by 'either/or' but by 'both/and'—by coexistence. This leads to greater complexity and decentralisation, but also allows a more focused view on details, layers and elements, which make up a building. The shell is no longer a monolithic, but decentralised and fragmentary. In these elements the possibility of comparison becomes higher and can be validated according to appropriateness and characteristics. This is common in the design of buildings, where all elements are assessed in their effects and selected accordingly, but central to spacing is to incorporate the social dimension of the doing of these elements. Materials, objects, buildings do not have an effect *on* people but *with* people. Architecture's agency is thus limited since countless actors participate in the making of its reality and this shifts the agency from the object to the network.

Architects do not control spacing. Yet, the loss of authority must not be considered 'a threat to professional credibility, but as an inevitable condition' as Awan, Schneider and Till point out and note that architects plan into uncertain futures (2011, 28). Approaching architecture with spacing and understanding a building as a field of possibilities, takes away its objectivity and its hard facts, and introduces a need for openness which might enable architecture to connect to a global and dynamic reality that shapes our daily lives, as Hilger demands (Hilger 2011). Holding on to the static object and ignoring architecture's 'dependencies' as Till puts it dismisses 'the potential for a reformulation of architectural practice that would resist its present marginalization' (2013, 2).

## 7.5

### Tracing an Architectural World in Flux: Some Methodological Reflections

Tracing how heterogeneous actors come together in the course of spacing, I followed the route of ethnographic research into the realm of architectural practice (Chapter 2.5). ANT provides tools to approach space, as we can follow the enactment of networks (Law 2002), and it furthermore allows acknowledging the different ways humans and nonhumans share agency (Yaneva 2009c). Thus, ANT proved to be of great help when entering and unravelling the complex and reciprocal relationships between building, practices, objects, materials and human bodies, which are necessary to grasp in the reality of monospace buildings, as I argued.

Buildings-in-use are large and complex objects, which weave together multiple times, spaces and actors. Moving into this world and following practices leads in all directions. Starting an empirical research into this messy reality of a building seems at first to be a hopeless undertaking. Observation often seemed to be plagued by bad timing or to simply be lacking in time. For example, I arrived just after the fire alarm went off, or when the yellow stele in the Rana Begum exhibition had been touched and moved by a visitor (Chapter 6.4). At the same time, the high visibility of the monospace greatly facilitated the investigation and made tracing in many situations possible. However, we can grasp reality only in fragments and this holds particularly true for buildings, as in all these connections, entanglements and mediations we are never able to fully unravel who else is acting.

I took different routes into this reality. Next to strategic in-depth interviews I engaged in observation and produced written accounts of events, which show the rich world out of which actors emerge. This is known terrain and ethnographies into the field of architectural practice and built environment have shown previously how we can trace the entanglement of humans and nonhumans (Houdart and Minato 2009; Yaneva 2009a, 2009b). The literature on empirically based studies into architectural space is scarce and so a first objective was to validate studying through experiencing buildings and space. Turning to specific experiences I followed with ANT a pragmatist tradition, which allows circumventing the dichotomy of subjective and objective space. ANT has not only proven helpful in understanding the building from 'within' and opening the complex relationships between humans and nonhumans in spacing, it allowed doing so without losing direct contact to the material world of the building—which I consider important for architectural research. With ANT we followed practices and witnessed the difference objects make in courses of action. Tracing objects in their doing and opening black boxes, decomposing them in smaller details and ingredients we traced the work that is necessary to produce space. Here, ANT allows acknowledging the

work that absent actors do, which again seems particularly important for the concerns of architecture.

Adding specific interview forms, the walking interview and the sketching interview, to the methodological repertoire of ANT, however, I departed from traditional approaches. Validating how spacing can be made visible and traced when approaching a building in practice both walking and sketching interviews have proven to be fruitful for studying buildings with ANT. While the first is known in the field of ethnographic research and valued for the rich data it produces (J. Evans and Jones 2011), the latter, known as the mental map interview (Gould and White 1974), is traditionally used in the field of geography and psychology to access mental spatial representations and knowledge. While both methods allow us to research spatial orientation, I used them in different terms.

The walking interview as introduced in Chapter 2.5 and explored with Chapter 4 is a particularly active mode of interview. Walking throughout the building during the course of the interview allowed the building itself to actively participate, to guide and redirect the trajectory of the interview. The building, specific objects and materials brought to attention, slowed the walk down or stopped it, reminding the person observing to mention them. The content of the interview never drifted at any point into a large narrative overview, but remained connected to the earthly reality of the building and the specific pragmatic knowledge of it. Many ingredients for spacing became visible, however not in a detached manner but in their daily setting. Winner for example touched and pushed the glass case to demonstrate problems with it in use (Chapter 4.3). At other moments we met people in the building—and Winner included them for a brief moment in the interview—providing new contact for me. What was an asset in my case can create problems when it comes to aspects of confidentiality or when people prefer to stay anonymous. Furthermore, only during the walking interview was I able to enter certain parts of the building that were otherwise locked. Of course, this form of interview is more time consuming than others and not suitable for every target group. That said, it is particularly helpful to approach a complex object such as a building.

I conducted two walking interviews with two recognised experts in working with the building. I think it would have been useful to have more walking interviews in addition to those done and to repeat them with the same people after a certain time had elapsed. I think this would have allowed tracing small changes in the building even better.

The sketching interview as also introduced in Chapter 2.5 and explored with Chapter 5 was especially aimed at the target group, at people I had to approach directly and with whom I could not pre-arrange an appointment for interview. These were thus short interviews ranging from 10 to 20 minutes, sketching while speaking about their experiences with the building had the enhancing effect that

these interviews also were embedded in the material world. Less autobiographical aspects than the doing with the building stayed in focus during the interview. The paper reminded interviewees to fill it, to think about the material world they engaged with. What could be taken to be a mental experiment was in the case of this study a tool to trace the engagements with the material world of the building. Specific events, experiences and practicalities came to the fore.

The sketching interview can pose challenges for the person interviewed who does not always feel comfortable with sketching. It proved useful to take notes about the drawing order to connect it with the transcript later. While a first question as warm-up seemed helpful, I had two questions which were rather descriptive before reaching my point of interest: 'Think about the different ways you move around here. Where did you go? And what did you do there?' However, sketching movements proved to be particularly difficult and here interviewees often rather explained than drew. Nevertheless, the things they engaged with on the path often became visible. While in classical mental map interviews care is taken that these do not take place in the area it is about, in my case I considered this to be irrelevant, because I did not want to test whether the objects could be drawn from the mind or placed correctly. Thus, it was not a cognitive test but an enhancing tool complementing the oral interview that allowed replacing to some extent a walking interview or shadowing.

## 7.6

### When Space Is Never 'Completed'

In examining the potential of an ANT-account into space in the field of architecture, I positioned this research at the intersection of architectural theory and mundane practice by directing attention to the typology of monospace. I argued that to understand a monospace building we need to turn to its lived reality and witness how space is not contained *in* a building but how it is a complex process that emerges *with* a building (Chapter 1). The book started with the discussion of how we can leave a traditional spatial understanding that still dominates the world of architecture behind (Chapter 2). A relational and processual understanding of space as we can find it currently within the social sciences and the humanities is still largely separated from the architects' spaces; the latter, a singular, inanimate and static form condemned to passivity, the former, active and vibrant, always in flux. This division is far-reaching, since it degrades architecture in its relation to the social to passive materiality, either as a tool or a mirror of social contexts embedded in causal relations (Yaneva 2012). While various scientists are making efforts to overcome this dichotomy, to push the boundaries, and blur the preoccupation with subjective and objective space, empirical studies into archi-

tectural space are generally scarce and tend to favour a human-centred approach. This book, then, provides from an ANT perspective a realist account into the space of a building in practice. Taking up the concept of spacing by Latour (1997) this study approached the topic of space from an empirical point of view with an extensive field research at the Sainsbury Centre for Visual Arts in Norwich, UK. In studying spacing empirically, it provides a processual, rich, and complex understanding of space and building and both its mutual entanglements with the human world. This approach contributes to the field of architectural theory and the current scholarship on the relationship of architecture to social life, while opening a scarcely explored area in the field of ANT-inspired anthropological works on architecture. Here, the study furthermore explored the methodological contributions that walking and sketching interviews can make particularly in the context of ANT-inspired research.

My account into the world of the Sainsbury Centre was not a critical one. I did not judge at any moment if something is good or bad, if something works well or does not and I did not put my descriptions into the discussion and comparison with, for example, other built references. In the same manner I do not provide suggestions on how to change this world, how to make it a 'better' actor in spacing. Descriptions are not innocent, however (Geertz 1973). Following the spacings with the building we looked at architecture in a different way and it may open new possibilities for architectural activity.

This book indeed shakes some traditional beliefs in the field of architecture. Not to point the finger at those who are 'stuck in the past'—looking into sociology tells us that even for those who are not concerned with shaping buildings along three-dimensional coordinates every day have difficulties in actually leaving a container thinking behind (Schroer 2006)—but to indicate the chances rather that come along when turning to architectural space as process. Spacing acknowledges the consequences of architecture and renders visible the biography of a building entangled with the human world. For architects this can contribute further awareness to the complexity of buildings (not only during the making, which they are perfectly aware of) but also after their completion. Buildings considered from the perspective of spacing are never completed. If we understand buildings as in process, and space as a hybrid human-non-human relation, then this results in a different understanding of what architecture is and does and shifts the field of obligation for architects. It is not the shaping of objects, neither its aesthetics nor style, but its relations with people in the course of life of a building that is central. And here the architect has social and political responsibility (amongst many others). Thus, it is not about thinking architecture as a tool to change people's lives but to think architecture as an open setting. Open for negotiations, open for change and processes. These thoughts are not fundamentally new, concepts such as flexibility and openness especially as they are linked to open plan and monospace

buildings reflect a (certain) wish to keep a building open for the future, open to the 'creative user' (Hill 2003). As I see it, the opportunity that spacing offers is to re-think existing architectural concepts and strategies and through this possibly contribute to developing other ways of doing and thinking architecture. Understanding stability and flexibility not as properties of buildings but as emergent in spacing shifts the focus to the 'architectural' (Yaneva 2010) and acknowledges architecture's dependencies (Till 2013).

ANT as a method makes it possible to debate the relationships of buildings and humans in more complex terms and thus to leave the idea of linear interactions and trajectories behind. The implications ANT has for space in the field of architecture are numerous. Entering the world of spacing we entered a world in flux. While museum spaces in particular produce highly stabilised environments, yet changing the spatial arrangements in terms of exhibition design over and over again, this poses an interesting field of research that needs to further investigate the tension between fluidity and stability. In this tension of stability and fluidity in connection to space an important interface seems to exist in which architecture can learn from ANT but also vice versa, ANT from architecture. An interface that should not only be fruitful for these two, but in general for the further debate on the relationship between architecture and the social in general.







# List of Figures

---

Unless otherwise stated, all illustrations and photographs are the author's.

## Chapter 1

- Fig. 1.1:** Box containing space.
- Fig. 1.2:** Isometric view. Junya Ishigami + Associates, KAIT Workshop, Kanagawa Institute of Technology, Japan, 2008. Drawing © Sabine Hansmann. Published by courtesy of Junya Ishigami + Associates.
- Fig. 1.3:** Isometric view. Ludwig Mies van der Rohe, Neue Nationalgalerie Berlin, Germany, 1968. Mies van der Rohe © VG Bild-Kunst, Bonn 2020; Drawing © Sabine Hansmann.
- Fig. 1.4:** Interior view (2014). KAIT Workshop. Photo © Sabine Hansmann; Published by courtesy of Junya Ishigami + Associates.
- Fig. 1.5:** Interior view (2014). Neue Nationalgalerie Berlin, exhibition *Sticks and Stones, eine Intervention* by David Chipperfield. Mies van der Rohe © VG Bild-Kunst, Bonn 2020; Photo © RAO.
- Fig. 1.6:** Isometric view. Foster + Partners, Sainsbury Centre for Visual Arts, University of East Anglia, Norwich, England, 1978.
- Fig. 1.7:** Interior view (2017). Sainsbury Centre for Visual Arts.

## Chapter 2

- Fig. 2.1:** Ethnographic collection.

## Chapter 3

- Fig. 3.1:** View of the eastern end of the Sainsbury Centre (2017).
- Fig. 3.2:** View of the building from the lake Yare (2016).
- Fig. 3.3:** Southern façade (2016).
- Fig. 3.4:** Site plan.
- Fig. 3.5:** Floor Plan. Groundfloor. Drawn on the basis of Foster + Partners. Drawing © Sabine Hansmann. Published by courtesy of Foster + Partners.

- Fig. 3.6:** Section A–A. Drawn after Powell (2010, 82f.). Drawing © Sabine Hansmann. Published by courtesy of Foster + Partners.
- Fig. 3.7:** Floor Plan. Underground, with phases of extension. Drawn on the basis of Powell (2010, 66f.). Drawing © Patryk Kujawa and Sabine Hansmann. Published by courtesy of Foster + Partners.
- Fig. 3.8:** Section B–B. Drawn after Powell (2010, 32f.). Drawing © Sabine Hansmann. Published by courtesy of Foster + Partners.
- Fig. 3.9:** Isometric exploded view with functional allocations.
- Fig. 3.10:** Visibility Graph Analysis at eye-level. Drawing © Patryk Kujawa.
- Fig. 3.11:** Entrance area of the museum with information stele (2017).
- Fig. 3.12:** View from the pedestrian bridge (2016).
- Fig. 3.13:** Reception desk (2017).
- Fig. 3.14:** Living Area (2017).
- Fig. 3.15:** Inside the East End Gallery with large glass showcases in the foreground (2016).
- Fig. 3.16:** View from the pedestrian bridge towards the first mezzanine (2016).
- Fig. 3.17:** Social Area of the department of Art History and World Art Studies between the two mezzanines (2016).
- Fig. 3.18:** View from the second mezzanine (2017).
- Fig. 3.19:** Photo archive inside the double-layered skin (2016).
- Fig. 3.20:** Conservatory of the School Area (2016).
- Fig. 3.21:** Low separating wall between entrance and school area redirecting visitors to the left (Living Area) or right (restaurant) when entering the building (2017).
- Fig. 3.22:** Directly adjacent, the second mezzanine and the restaurant (2017).
- Fig. 3.23:** Kit of parts. Drawn after Powell (2010, 39). Drawing © Carola Plappert, Sabine Hansmann. Published by courtesy of Foster + Partners.

## Chapter 4

- Fig. 4.1:** Ethnographic collection, Gallery 1. Photo 1 (upper left) © Andy Crouch.
- Fig. 4.2:** First stop and actors.
- Fig. 4.3:** Ethnographic collection, East End Gallery.
- Fig. 4.4:** Second stop and actors.
- Fig. 4.5:** Ethnographic collection, Living Area.
- Fig. 4.6:** Third stop and actors.

## Chapter 5

- Fig. 5.1: Sketch 1 by Mr Smith/VL2Z.
- Fig. 5.2: Sketch 2 by Mr Smith/VL2Z.
- Fig. 5.3: Sketch 3 by Mr Smith/VL2Z.
- Fig. 5.4: Sketch 1 by Mrs Smith/LN3F.
- Fig. 5.5: Sketch 1 and 2 by Mr Walker/VG4T.
- Fig. 5.6: Sketch 3 by Mr Walker/VG4T.
- Fig. 5.7: Sketch 2 and 3 by Séverine/PE6Z.
- Fig. 5.8: Sketch 2 by Ms Abbey/AA2Z.
- Fig. 5.9: Sketch 1–3 by Lisa/BE7Z.
- Fig. 5.10: Sketch 2 by Bill/BS7X.
- Fig. 5.11: Sketch 3 by Bill/BS7X.

## Chapter 6

- Fig. 6.1: Isometric view tracing the network of light as visible in the three settings. Drawing © Fabian Brenne and Sabine Hansmann.
- Fig. 6.2: Ethnographic collection of first setting.
- Fig. 6.3: Student in front of a Computer (2017).
- Fig. 6.4: Glass railings in the entrance area but also the rubber floors convey the light (2017).
- Fig. 6.5: Slats along the wall and the roof (partially perforated) (2017).
- Fig. 6.6: In between the louvre system in the roof (2016).
- Fig. 6.7: Baby Asleep by Jacob Epstein with combination of sun light and artificial spot light (2017).
- Fig. 6.8: A theatre fabric on both sides at the edge of the second mezzanine should reduce the amount of light for the artworks (2017).
- Fig. 6.9: Living Area in cleaning light (August 2017).
- Fig. 6.10: Living Area in spot light (August 2017).
- Fig. 6.11: Smith's collection of used light bulbs (2016).
- Fig. 6.12: Ethnographic collection of second setting.
- Fig. 6.13: Ethnographic collection of third setting.



# Building Details<sup>1</sup>

---

Client:

The University of East Anglia  
Sir Robert and Lady Sainsbury

Foster Associates project team:

Norman Foster, Wendy Foster,  
Arthur Branthwaite, Loren Butt, John Calvert, Chubby Chhabra, Spencer de  
Grey, Jim Elsdon, Howard Filbey, Roy Fleetwood, Diane Haigh, Birkin Haward,  
Richard Horden, Caroline Lwin, David Nelson, Tomm Nyhuus, Tony  
Pritchard, Ian Ritchie, Judith Warren, John Yates, Bodo Zapp

Structural Engineer: Anthony Hunt Associates

Mechanical and Electrical Engineer: Foster Associates

Quantity Surveyor: Hanscomb Partnership

Lighting: Claude R. Engle

Acoustics: Sound Research Laboratories

Landscaping: Lanning Roper

Drainage: John Taylor & Sons

Cladding: Tony Pritchard

Display and Exhibition Lighting: George Sexton III

Graphics: Minale Tattersfield Provinciali

Data:

External length	131.4 m
Internal length	122.4 m
External with	35.0 m
Internal width	29.0 m
External height	10.3 m

---

<sup>1</sup> Facts about the project team after Powell (2010, 90); the dimensions stem from a pamphlet from the Sainsbury Centre.

Internal height	7.3 m
Ground floor area	3550.0 m <sup>2</sup>
Mezzanine floor area	835.0 m <sup>2</sup>
Basement floor area	1066.0 m <sup>2</sup>
Service core area	735.0 m <sup>2</sup>
Total area	6186.0 m <sup>2</sup>

## Bibliography

---

- Akrich, Madeleine. 1992. 'The De-Description of Technical Objects'. In *Shaping Technology/Building Society: Studies in Sociotechnical Change*, edited by Wiebe E. Bijker and John Law, translated by Geoffrey C. Bowker, 205–24. Inside technology. Cambridge, Mass.: MIT Press.
- Akrich, Madeleine, and Bruno Latour. 1992. 'A Summary of a Convenient Vocabulary for the Semiotics of Human and Nonhuman Assemblies'. In *Shaping Technology/Building Society: Studies in Sociotechnical Change*, edited by Wiebe E. Bijker and John Law, 259–64. Inside Technology. Cambridge, Mass.: MIT Press.
- Albertsen, Niels, and Bülent Diken. 2004. 'Artworks' Networks: Field, System or Mediators?' *Theory, Culture & Society* 21 (3): 35–58. <https://doi.org/10.1177/0263276404043619>
- Anderson, Jon. 2004. 'Talking Whilst Walking: A Geographical Archaeology of Knowledge'. *Area* 36 (3): 254–61. <https://doi.org/10.1111/j.0004-0894.2004.00222.x>
- Appadurai, Arjun, ed. 2013. 'Introduction: Commodities and the Politics of Value'. In *The Social Life of Things: Commodities in Cultural Perspective*, 11. print, 3–63. Cambridge, Mass.: Cambridge Univ. Press. <https://doi.org/10.1017/CBO9780511819582.003>
- Arnheim, Rudolf. 1977. *The Dynamics of Architectural Form: Based on the 1975 Mary Duke Biddle Lectures at the Cooper Union*. Berkeley: Univ. of California Press.
- Arts Council England. 2016. 'Government Indemnity Scheme. Guidelines for Non-National Institutions'. 13 March 2016. [http://www.artscouncil.org.uk/sites/default/files/download-file/GIS\\_Non\\_national\\_guidelines\\_2016.pdf](http://www.artscouncil.org.uk/sites/default/files/download-file/GIS_Non_national_guidelines_2016.pdf).
- Austin, John Langshaw. 1972. *Zur Theorie der Sprechakte (How to Do Things with Words)*. Universal-Bibliothek. Stuttgart: Reclam.
- Awan, Nishat, Tatjana Schneider, and Jeremy Till. 2011. *Spatial Agency: Other Ways of Doing Architecture*. Abingdon: Routledge.
- Banham, Reyner. 1962. *Guide to Modern Architecture*. London: Architectural Press.

- . 2000. 'Foster Associates [1979]'. In *On Foster ... Foster On*, edited by David Jenkins, originally published in the catalogue accompanying the Foster Associates exhibition at the RIBA Heinz Gallery, 1979, 68–87. Munich: Prestel.
- Beck, Haig, ed. 1979. 'Foster Associates' Sainsbury Centre' AD, *Architectural Design* 49 (2).
- Belliger, Andréa, and David J. Krieger, eds. 2006a. *ANThology: Ein einführendes Handbuch zur Akteur-Netzwerk-Theorie*. ScienceStudies. Bielefeld: transcript.
- . 2006b. 'Einführung in die Akteur-Netzwerk Theorie'. In *ANThology: ein einführendes Handbuch zur Akteur-Netzwerk-Theorie*, edited by Andréa Belliger and David J. Krieger, 13–50. ScienceStudies. Bielefeld: transcript.
- Benthall, Jonathan. 1989. 'An Interview with Sir Robert and Lady Sainsbury'. *Anthropology Today* 5 (1): 2–5. <https://doi.org/10.2307/3032851>
- Best, Alastair. 1982. 'Foster at Play'. In *The Architects' Journal* 48 (176): 40–41.
- Bijker, Wiebe E., Thomas Hughes, and Trevor J. Pinch, eds. 1987. *The Social Construction of Technological Systems: New Directions in the Sociology and History of Technology*. Cambridge, Mass.: The MIT Press.
- Blaser, Werner. 2001. *Mies van der Rohe, Crown Hall: Illinois Institute of Technology, The Department of Architecture*. Basel: Birkhäuser.
- Blau, Judith R. 1984. *Architects and Firms: A Sociological Perspective on Architectural Practice*. Cambridge, Mass.: MIT Press.
- Böhme, Gernot. 1993. 'Atmosphere as the Fundamental Concept of a New Aesthetics'. Translated by David Roberts. *Thesis Eleven* 36 (1): 113–26. <https://doi.org/10.1177/072551369303600107>
- . 2017. *The Aesthetics of Atmospheres*, edited by Jean-Paul Thibaud. Abingdon, Routledge.
- Boys, Jos. 1978. 'Too Much Daylight at Sainsbury Centre Could Damage Exhibits'. *Building Design* (8 September).
- Bramante, Gabriele. 1999. *Foster Associates: Willis, Faber & Dumas Building, Ipswich, 1975*. Architecture in Detail series published by Phaidon, repacked as Architecture 3s: Pioneering British 'High Tech'. London: Phaidon.
- Brand, Stewart. 1994. *How Buildings Learn: What Happens after They're Built*. New York: Viking Penguin.
- Broadly, Maurice. 1972. 'Social Theory in Architectural Design'. In *People and Buildings*, edited by Robert Gutman, 170–85. New York: Basic Books. <https://doi.org/10.4324/9781315126197-14>
- Buchanan, Ian. 2000. *Michel de Certeau: Cultural Theorist*. Theatre, Culture & Society. London: SAGE Publications.
- Bunn, Stephanie von. 2002. 'Mobilität und Flexibilität volkstümlicher Behausungen'. In *Living in Motion: Design und Architektur für flexibles Wohnen*, edited by Mathias Schwartz-Clauss, 132–71. Weil am Rhein: Vitra Design Museum. Exhibition catalogue.



- Camuffo, Dario. 2001. 'Environmental Monitoring in Four European Museums'. *Atmospheric Environment* 35: 127–40. [https://doi.org/10.1016/S1352-2310\(01\)00088-7](https://doi.org/10.1016/S1352-2310(01)00088-7)
- Certeau, Michel de. 1984 [1980]. *The Practice of Everyday Life*. Translated by Steven F. Rendall. Berkeley: Univ. of California Press.
- Clifford, James. 1997. *Routes: Travel and Translation in the Late Twentieth Century*. Cambridge, Mass.: Harvard Univ. Press.
- Cresswell, Tim, and Peter Merriman. 2011. *Geographies of Mobilities: Practices, Spaces, Subjects*. Farnham, Surrey: Ashgate.
- Crysler, C. Greig, Stephen Cairns, and Hilde Heynen, eds. 2012. *The SAGE Handbook of Architectural Theory*. Los Angeles: SAGE Publications.
- Cuff, Dana. 1991. *Architecture: The Story of Practice*. Cambridge, Mass.: MIT Press.
- Curtis, William J. R. 1982. *Modern Architecture since 1900*. Oxford: Phaidon.
- Cuttle, Christopher. 2007. *Light for Art's Sake: Lighting for Artworks and Museum Displays*. Oxford: Butterworth-Heinemann.
- Deleuze, Gilles, and Félix Guattari. 1987. *A Thousand Plateaus: Capitalism and Schizophrenia*. Translated by Brian Massumi. Minneapolis: Univ. of Minnesota Press.
- Delitz, Heike. 2009a. *Architektursoziologie*. Bielefeld: transcript. <https://doi.org/10.14361/9783839410318>
- . 2009b. 'Architektur + Soziologie = Architektursoziologie'. In *Aus Politik und Zeitgeschichte* 25 (Architektur der Gesellschaft): 11–16.
- . 2010. *Gebaute Gesellschaft: Architektur als Medium des Sozialen*. Frankfurt am Main: Campus.
- Denk, Andreas, Uwe Schröder, and Rainer Schützeichel. 2008. 'Raumwende'. *der architekt. Zeitschrift des Bundes Deutscher Architekten*, 3: 18.
- . 2016. *Architektur, Raum, Theorie: Eine Kommentierte Anthologie*. Tübingen: Wasmuth Ernst Verlag.
- Department for Digital, Culture, Media & Sport, and Ed Vaizey. 2012. "Modern Classic" Sainsbury Centre Grade II\* Listed. GOV.UK. 21 December 2012. <https://www.gov.uk/government/news/modern-classic-sainsbury-centre-grade-ii-listed>.
- Dewey, John. 1929. *Experience and Nature*. London: Allen & Unwin. <https://doi.org/10.1037/13377-000>
- DiMaggio, Paul. 1996. 'Introduction: Special Triple Issue on "Museum Research"'. *Poetics* 24 (2–4): 81–86. [https://doi.org/10.1016/S0304-422X\(96\)90003-0](https://doi.org/10.1016/S0304-422X(96)90003-0)
- Döring, Jörg. 2010. 'Spatial Turn'. In *Raum: Ein Interdisziplinäres Handbuch*, edited by Stephan Günzel, 90–99. Stuttgart: Metzler.
- Döring, Jörg, and Tristan Thielmann. 2008. *Spatial Turn: Das Raumparadigma in den Kultur- und Sozialwissenschaften*. Bielefeld: transcript. <https://doi.org/10.14361/9783839406830>

- Dormer, Peter, and Stefan Muthesius. 2001. *Concrete and Open Skies: Architecture at the University of East Anglia, 1962–2000*. London: Unicorn.
- Doucet, Isabelle, and Kenny Cupers. 2009. 'Agency in Architecture: Reframing Criticality in Theory and Practice'. *Footprint* 3 (1): 1–6.
- Downing, Ron. 1979. *Sainsbury Centre for Visual Arts: The Gift*. Art, Documentary, Television. Anglia Television.
- Downs, Roger M, and David Stea. 1977. *Maps in Minds: Reflections on Cognitive Mapping*. Univ. of Michigan: Harper & Row.
- Dudley, Sandra, ed. 2010. *Museum Materialities: Objects, Engagements, Interpretations*. Abingdon: Routledge.
- . 2012. 'Materiality Matters: Experiencing the Displayed Object'. *Univ. of Michigan Working Papers in Museum Studies* 8.
- Dünne, Jörg, and Stephan Günzel, eds. 2006. *Raumtheorie: Grundlagentexte aus Philosophie und Kulturwissenschaften*. Frankfurt am Main: Suhrkamp.
- Einstein, Albert. 1954. 'Foreword'. In *Concepts of Space: The History of Theory of Space in Physics*, by Max Jammer, xi–xvi. Cambridge, Mass.: Harvard Univ. Press.
- Evans, James, and Phil Jones. 2011. 'The Walking Interview: Methodology, Mobility and Place'. *Applied Geography* 31 (2): 849–58. <https://doi.org/10.1016/j.apgeog.2010.09.005>
- Evans, Robin. 1982. *The Fabrication of Virtue: English Prison Architecture, 1750–1840*. Cambridge: Cambridge Univ. Press.
- Falk, John H., Lynn D. Dierking, and Marianna Adams. 2006. 'Living in a Learning Society: Museums and Free-Choice Learning'. In *A Companion to Museum Studies*, edited by Sharon Macdonald, 324–39. Blackwell Companions in Cultural Studies 12. Malden, MA: Blackwell Pub.
- Ferry, W. Hawkins. 1987. *The Legacy of Albert Kahn*. Detroit: Wayne State Univ. Press.
- Fontenas, Hugues. 1998. 'Le Temps Improbable de La Construction'. In *LABFAC: Laboratory for Architecture*, edited by Finn Geipel and Nicolas Michelin, 9, 97–108. Supplémentaires. Paris: Centre Pompidou.
- Forty, Adrian. 2004. *Words and Buildings: A Vocabulary of Modern Architecture*. New York: Thames & Hudson.
- Foster + Partners. 2018. 'Sainsbury Centre for Visual Arts'. Foster + Partners. 10 March 2018. <http://www.fosterandpartners.com/projects/sainsbury-centre-for-visual-arts/>.
- Foster Associates. 1970. 'Recent Work'. *Architectural Design*, 5: 235–58.
- Foster, Norman, and Kenneth Powell. 2010. *Sainsbury Centre for Visual Arts - Foster & Partners*. Edited by David Jenkins. Munich: Prestel.
- Foucault, Michel. 1980. *Power/Knowledge: Selected Interviews and Other Writings, 1972-1977*, edited by Colin Gordon, translated by Colin Gordon et. al. New York: Pantheon Books.

- . 1986. 'Of Other Spaces'. Based on a lecture given in March 1967, translated by Jay Miskowiec. *Diacritics*, 16 (1). <https://doi.org/10.2307/464648>
- . 1995 [1977]. *Discipline and Punish: The Birth of the Prison*. Second Vintage Books edition. Translated by Alan Sheridan. New York: Vintage Books.
- Geertz, Clifford. 1973. *The Interpretation of Cultures: Selected Essays*. New York: Basic Books.
- Geipel, Finn, Ken Koch, and Katja Thorwarth. 2011. *Monospace*. Berlin: self-published LIA.
- Geipel, Finn, and Sabine Hansmann. Forthcoming. 'Über Hüllen und Werden'. In *Zur Typologie der Hütte*, edited by Karin Krauthausen and Rebekka Ladewig. Zürich: Diaphanes.
- Giedion, Sigfried. 1954 [1941]. *Space, Time and Architecture: The Growth of a New Tradition*. Third ed. The Charles Eliot Norton Lectures. 39. Cambridge: Harvard Univ. Press.
- Gieryn, Thomas F. 2002. 'What Buildings Do'. *Theory and Society* 31 (1): 35–74. <https://doi.org/10.1023/A:1014404201290>
- Gomart, Emilie, and Antoine Hennion. 1999. 'A Sociology of Attachment: Music Amateurs, Drug Users'. *The Sociological Review* 47 (1\_suppl): 220–47. <https://doi.org/10.1111/j.1467-954X.1999.tb03490.x>
- Gould, Peter, and Rodney White. 1974. *Mental Maps*. Second edition. Boston: Allen & Unwin. <https://doi.org/10.4324/9780203163757>
- Graham, Stephen, and Nigel Thrift. 2007. 'Out of Order: Understanding Repair and Maintenance'. *Theory, Culture & Society* 24 (3): 1–25. <https://doi.org/10.1177/0263276407075954>
- Gropius, Walter. 1954. 'Eight Steps Towards a Solid Architecture'. In *Architecture Culture 1943–1968: A Documentary Anthology*, edited by Joan Ockman, 177–80. New York: Columbia Book of Architecture.
- Guggenheim, Michael. 2009. 'Building Memory: Architecture, Networks and Users'. *Memory Studies* 2 (1): 39–53. <https://doi.org/10.1177/1750698008097394>
- . 2010. 'Mutable Immobiles. Building Conversion as a Problem of Quasi-Technologies'. In *Urban Assemblages: How Actor-Network Theory Changes Urban Studies*, edited by Ignacio Fariás and Thomas Bender, 161–78. Abingdon: Routledge.
- Habraken, John. 1972. *Supports: An Alternative to Mass Housing*. London: Architectural Press.
- Hansmann, Sabine, and Finn Geipel, eds. 2019. *Raummaschine: Exploring Manifold Spaces*. Berlin: Jovis Verlag.
- Hauser, Susanne, Christa Kamleithner, and Roland Meyer, eds. 2011. *Architekturwissen: Grundlagentexte aus den Kulturwissenschaften*. Vol. 1: Zur Ästhetik des sozialen Raumes. 2 vols. Bielefeld: transcript.
- . eds. 2013. *Architekturwissen: Grundlagentexte aus den Kulturwissenschaften*. Vol. 2: Zur Logik des sozialen Raumes. 2 vols. Bielefeld: transcript.

- Hein, Georg E. 2006. 'Museum Education'. In *A Companion to Museum Studies*, edited by Sharon Macdonald, 340–52. Blackwell Companions in Cultural Studies 12. Malden, MA: Blackwell Pub.
- Hennion, Antoine. 2010. 'Loving Music: From a Sociology of Mediation to a Pragmatics of Taste'. *Revista Comunicar* 17 (34): 25–33. <https://doi.org/10.3916/C34-2010-02-02>
- Hertzberger, Herman. 2009 [1991]. *Lessons for Students in Architecture*. Sixth revised edition. Rotterdam: 010 Publishers.
- Hetherington, Kevin. 1997. 'Museum Topology and the Will to Connect'. *Journal of Material Culture* 2 (2): 199–218. <https://doi.org/10.1177/135918359700200203>
- . 1999. 'From Blindness to Blindness: Museums, Heterogeneity and the Subject'. *The Sociological Review* 47 (1\_suppl): 51–73. <https://doi.org/10.1111/j.1467-954X.1999.tb03482.x>
- Heynen, Hilde. 2013. 'Space as Receptor, Instrument or Stage: Notes on the Interaction Between Spatial and Social Constellations'. *International Planning Studies* 18 (3–4): 342–57. <https://doi.org/10.1080/13563475.2013.833729>
- Hildenbrand, Adolf. 1993 [1893]. 'The Problem of Form in the Fine Arts'. In *Empathy, Form, and Space: Problems in German Aesthetics 1873–1893*, edited by Robert Vischer, Harry Francis Mallgrave and Eleftherios Ikononou, translated by Francis Mallgrave, 227–79. Text & Documents. Santa Monica, CA: Getty Center for the History of Art and the Humanities; Distributed by the Univ. of Chicago Press.
- Hilger, Christina. 2011. *Vernetzte Räume: Plädoyer für den Spatial Turn in der Architektur*. Materialitäten 15. Bielefeld: transcript. <https://doi.org/10.14361/transcript.9783839414996>
- Hill, Jonathan. 2003. *Actions of Architecture Architects and Creative Users*. London: Routledge. <https://doi.org/10.4324/9780203327210>
- Hilpert, Thilo, ed. 2001. *Mies in Postwar Germany: Project 5207, unbuilt*. *The Mannheim Theater*. E.A. Seemann. Exhibition catalogue.
- Historic England. 2017. 'Sainsbury Centre'. 16 March 2017. <https://historicengland.org.uk/listing/the-list/list-entry/1409810>.
- Hooper, Steven, ed. 1997. *Robert and Lisa Sainsbury Collection: Catalogue in Three Volumes*. New Haven, Norwich: Yale Univ. Press; Univ. of East Anglia.
- Hooper-Greenhill, Eilean. 2000. *Museums and the Interpretation of Visual Culture*. Repr. Abingdon: Routledge.
- Houdart, Sophie, and Chihiro Minato. 2009. *Kuma Kengo: An Unconventional Monograph*. Translated by Lucy Lyall Grant. Paris: Ed. Donner Lieu.
- Inoue, Mitsuo. 1985. *Space in Japanese Architecture*. New-York: Weatherhill.
- Ishigami, Junya. 2008. *Junya Ishigami: small images*. Contemporary Architect's Concept Series 2. Tokyo: INAX Publishing.
- . 2010. 'Junya Ishigami'. *The Japan Architect* 79.

- Jacobs, Jane M., and Peter Merriman. 2011. 'Practising Architectures'. *Social & Cultural Geography* 12 (3): 211–22. <https://doi.org/10.1080/14649365.2011.565884>
- James, William. 1895. 'Is Life Worth Living?' *The International Journal of Ethics* 6 (1): 1–24. <https://doi.org/10.1086/intejethi.6.1.2375619>
- . 1912. *Essays in Radical Empiricism*. New York: Longmans, Green, and Co.
- Jay, Martin. 2006. *Songs of Experience: Modern American and European Variations on a Universal Theme*. Berkeley: Univ. of California Press.
- Jencks, Charles. 1991 [1977]. *The Language of Post-Modern Architecture*. Sixth revised enlarged edition. London: Academy Editions.
- Jenkins, David, ed. 2000. *On Foster ... Foster On*. Munich, New York: Prestel.
- . ed. 2002. *Norman Foster: Works 1*. Eponymous Series. Munich: Prestel.
- Jodidio, Philip. 1997. *Sir Norman Foster*. Köln: Taschen.
- Jones, Geoff, Christine McLean, and Paolo Quattrone. 2004. 'Spacing and Timing'. *Organization* 11 (6): 723–41. <https://doi.org/10.1177/1350508404047248>
- Jormakka, Kari. 2002. *Flying Dutchmen: Motion in Architecture*. Basel: Birkhäuser.
- . 2005. *Genius Locomotionis*. Vienna: Edition Selene.
- Kamleithner, Christa. 2014. 'Was Architektur macht'. *ARCH+ Zeitschrift für Architektur und Städtebau* 217: 156–63.
- Kim, Ransoon. 2009. 'The Tectonically Defining Space of Mies van der Rohe'. *Architectural Research Quarterly* 13 (3-4): 251–60. <https://doi.org/10.1017/S1359135510000102>
- King, Anthony D., ed. 2003 [1980]. *Buildings and Society: Essays on the Social Development of the Built Environment*. London: Routledge & Kegan Paul.
- Kirchberg, Volker, and Martin Tröndle. 2012. 'Experiencing Exhibitions: A Review of Studies on Visitor Experiences in Museums'. *Curator: The Museum Journal* 55 (4): 435–52. <https://doi.org/10.1111/j.2151-6952.2012.00167.x>
- Klonk, Charlotte. 2009. *Spaces of Experience: Art Gallery Interiors from 1800 to 2000*. New Haven: Yale Univ. Press.
- Kuo, Jeannette. 2013. *A-Typical Plan: Projects and Essays on Identity, Flexibility and Atmosphere in the Office Building*. Zurich: Park Books.
- Kusenbach, Margarethe. 2003. 'Street Phenomenology: The Go-Along as Ethnographic Research Tool'. *Ethnography* 4 (3): 455–85. <https://doi.org/10.1177/146613810343007>
- Lambot, Ian, ed. 1989. *Norman Foster, Foster Associates: Buildings and Projects*. Norman Foster: Buildings and Projects, Vol. 2: 1971–1978. Hong Kong: Watermark.
- . ed. 1996. *Norman Foster: Foster Associates, Buildings and Projects*. Norman Foster, Buildings and Projects, Vol. 4: 1982–1989. Basel: Birkhäuser; Haslemere: Watermark.
- Lambot, Ian, and Graham Vickers. 2002. 'Sainsbury Centre for Visual Arts'. In *Norman Foster: Works*, edited by David Jenkins, 370–419. Vol.1. Munich: Prestel.

- Larson, Magali Sarfatti. 1995. *Behind the Postmodern Facade: Architectural Change in Late Twentieth-Century America*. Berkeley: Univ. California Press.
- Latour, Bruno. 1988. 'Mixing Humans and Nonhumans Together: The Sociology of a Door-Closer'. *Social Problems* 35 (3): 298-310. Published under pseudonym: Jim Johnson.
- . 1991. *We Have Never Been Modern*. Cambridge, Mass.: Harvard Univ. Press.
- . 1992. 'Where Are the Missing Masses? The Sociology of a Few Mundane Artifacts'. In *Shaping Technology/Building Society: Studies in Sociotechnical Change*, edited by Wiebe E. Bijker and John Law, 225-58. Inside Technology. Cambridge, Mass.: MIT Press.
- . 1994. 'On Technical Mediation'. *Common Knowledge* 3 (2): 29-64.
- . 1997. 'Trains of Thoughts—Piaget, Formalism and the Fifth Dimension'. *Common Knowledge* 6 (3): 170-91.
- . 1999a. 'Fatures/Fractures: From the Concept of Network to the Concept of Attachment'. Translated by Monique Girard Stark. *RES: Anthropology and Aesthetics* 36: 20-31. <https://doi.org/10.1086/RESv36n1ms20167474>
- . 1999b. *Pandora's Hope: Essays on the Reality of Science Studies*. Cambridge, Mass.: Harvard Univ. Press.
- . 2005. *Reassembling the Social: An Introduction to Actor-Network-Theory*. Oxford: Oxford Univ. Press.
- Latour, Bruno, and Steve Woolgar. 1979. *Laboratory Life: The Social Construction of Scientific Facts*. Beverly Hills, California: SAGE.
- Latour, Bruno, and Alben Yaneva. 2008. 'Give Me a Gun and I Will Make All Buildings Move: An ANT's View of Architecture'. In *Explorations in Architecture: Teaching, Design, Research*, edited by Reto Geiser, 80-89. Basel: Birkhäuser.
- Laux, Henning. 2011. 'Latours Akteure. Ein Beitrag zur Neuvermessung der Handlungstheorie'. In *Akteur - Individuum - Subjekt*, edited by Nico Lüdtke and Hironori Matsuzaki, 275-300. Wiesbaden: VS Verlag für Sozialwissenschaften. [https://doi.org/10.1007/978-3-531-93463-1\\_13](https://doi.org/10.1007/978-3-531-93463-1_13)
- Law, John. 2002. 'Objects and Spaces'. *Theory, Culture & Society* 19 (5-6): 91-105. <https://doi.org/10.1177/026327602761899165>
- Le Corbusier. 2007 [1923]. *Towards an Architecture*, introduction by Jean-Louis Cohen, translation by John Goodman. Los Angeles: Getty Research Institute.
- Ledinskaya, Maria. 2015. 'Buildings Survey: The Sainsbury Centre for Visual Arts'. Unpublished survey, MA Cultural Heritage and Museum Studies. University of East Anglia.
- Lefavre, Liane, and Alexander Tzonis. 2000. 'Architecture En Réseau et Minimalisme Cartésien'. *L'Architecture d'Aujourd'hui* 327 (Labfac): 54-61.
- Lefebvre, Henri. 2015 [1974]. *The Production of Space*. Translated by Donald Nicholson-Smith. Malden, Mass.: Blackwell.

- Leuenberger, Theresia. 2018. *Architektur als Akteur? Zur Soziologie der Architektur-erfahrung*. Bielefeld: transcript. <https://doi.org/10.14361/9783839442647>
- Leyk, Manja. 2010. *Von mir aus ... Bewegter Leib - Flüchtiger Raum: Studie über den architektonischen Bewegungsraum*. Würzburg: Königshausen & Neumann.
- Lipman, Alan. 1969. 'The Architectural Belief System and Social Behaviour'. *The British Journal of Sociology* 20 (2): 190–204. <https://doi.org/10.2307/588529>
- Loukissas, Yanni A. 2012. *Co-Designers: Cultures of Computer Simulation in Architecture*. Abingdon: Routledge. <https://doi.org/10.4324/9780203123065>
- Löw, Martina. 2001. *Raumsoziologie*. Suhrkamp Taschenbuch Wissenschaft. Frankfurt am Main: Suhrkamp.
- . 2008. 'The Constitution of Space: The Structuration of Spaces Through the Simultaneity of Effect and Perception'. *European Journal of Social Theory* 11 (1): 25–49. <https://doi.org/10.1177/1368431007085286>
- . 2016. *The Sociology of Space: Materiality, Social Structures, and Action*. Translated by Donald Goodwin. Cultural Sociology. New York: Palgrave Macmillan.
- Lynch, Kevin. 1960. *The Image of the City*. Cambridge, Mass.: MIT Press.
- Macdonald, Sharon. 2006. 'Expanding Museum Studies: An Introduction'. In *A Companion to Museum Studies*, edited by Sharon Macdonald, 2–12. Blackwell Companions in Cultural Studies 12. Malden, MA: Blackwell Pub. <https://doi.org/10.1111/b.9781405108393.2006.00003.x>
- Macdonald, William Lloyd. 1981. *The Pantheon: Design, Meaning, and Progeny*. Cambridge, Mass.: Harvard Univ. Pr.
- Mainzer, Klaus. 2010. '1.1. Naturwissenschaften'. In *Raum: Ein Interdisziplinäres Handbuch*, edited by Stephan Günzel, 1–23. Stuttgart: Metzler.
- Martin, Emily. 1994. *Flexible Bodies: Tracking Immunity in American Culture from the Days of Polio to the Age of AIDS*. Boston: Beacon Press.
- Mau, Bruce. 2004. *Massive Change*. London, New York: Phaidon.
- May, Mark. 1992. *Mentale Modelle von Städten: Wissenspsychologische Untersuchungen am Beispiel der Stadt Münster*. Münster: Waxmann.
- McNeill, Donald. 2005. 'In Search of the Global Architect: The Case of Norman Foster (and Partners)'. *International Journal of Urban & Regional Research* 29 (3): 501–15. <https://doi.org/10.1111/j.1468-2427.2005.00602.x>
- Moholy-Nagy, László. 1967 [1928 and 1947]. *The New Vision and Abstract of an Artist*. The Documents of Modern Art 3. New York: Wittenborn.
- Mol, Annemarie. 2002. *The Body Multiple: Ontology in Medical Practice*. Science and Cultural Theory. Durham: Duke Univ. Press.
- . 2010. 'Actor-Network Theory: Sensitive Terms and Enduring Tensions'. *Kölner Zeitschrift für Soziologie und Sozialpsychologie*. Sonderheft 50 (1): 253–69.
- Moore, Rowan. 2002. 'Norman's Conquest'. *Prospect*. 23 March 2002. <https://www.prospectmagazine.co.uk/magazine/norman-foster-profile>.

- Murdoch, Jonathan. 1997. 'Towards a Geography of Heterogeneous Associations'. *Progress in Human Geography* 21 (3): 321–37. <https://doi.org/10.1191/030913297668007261>
- . 1998. 'The Spaces of Actor-Network Theory'. *Geoforum* 29 (4): 357–74. [https://doi.org/10.1016/S0016-7185\(98\)00011-6](https://doi.org/10.1016/S0016-7185(98)00011-6)
- Neumeyer, Fritz. 1994. *Artless Word: Mies van der Rohe on the Building Art*. Translated by Mark M. Jarzombek. Cambridge, Mass.: MIT Press.
- Newton, Isaac. 1872. *Mathematische Principien der Naturlehre*. Edited and commented by J. Ph. Wolfers. Berlin: Verlag von Robert Oppenheim.
- Ngo, Dung, and Adi Shamir Zion, eds. 2002. *Open House: Unbound Space and the Modern Dwelling*. London: Thames & Hudson.
- November, Valérie, Eduardo Camacho-Hübner, and Bruno Latour. 2010. 'Entering a Risky Territory: Space in the Age of Digital Navigation'. *Environment and Planning D: Society and Space* 28 (4): 581–99. <https://doi.org/10.1068/d10409>
- Oxford English Dictionary. 1989a. "'transparent, Adj. (and n.)'". 9 November 2017. <http://www.oed.com/view/Entry/204969>.
- . 1989b. "'explore, v.'". 21 January 1989. <http://www.oed.com/view/Entry/66668?rskey=okKSrS&result=2>.
- Pallasmaa, Juhani. 2012. *The Eyes of the Skin: Architecture and the Senses*. Third edition. Chichester: Wiley.
- Pavitt, Jane, and Abraham Thomas, eds. 2018a. *Superstructure: The Making of the Sainsbury Centre*. Norwich: Sainsbury Centre of Visual Arts, Univ. of East Anglia. Exhibition catalogue.
- . 2018b. 'Superstructures: The New Architecture 1960–1990'. In *Superstructure: The Making of the Sainsbury Centre*, edited by Jane Pavitt and Abraham Thomas, 12–53. Norwich: Sainsbury Centre of Visual Arts, Univ. of East Anglia. Exhibition catalogue.
- Pawley, Martin. 1984. 'Building Revisit: Sainsbury Centre'. *Architects' Journal* 180 (27): 39–44.
- . 2001. *Norman Foster: A Global Architecture*. London: Thames & Hudson.
- Peckham, Andrew. 1979. 'Foster Associates' Sainsbury Centre. This Is the Modern World'. *Architectural Design* 49 (2): 2–68, 92–93.
- Peppiatt, Michael. 2006. *Francis Bacon in the 1950s*. New Haven, Conn.: Yale Univ. Press; in association with the Sainsbury Centre for Visual Arts, Univ. of East Anglia.
- Pevsner, Nikolaus. 1942. *An Outline of European Architecture*. Harmondsworth: Penguin Books.
- . 1976. *A History of Building Types*. Princeton: Princeton Univ. Press.
- Place, Jean Michel, ed. 2000. 'LABFAC'. *L'Architecture d'Aujourd'hui* 327.



- Platner, Samuel Ball. 2015. *A Topographical Dictionary of Ancient Rome*. Edited by Thomas Ashby. Cambridge Library Collection. Archaeology. Cambridge: Cambridge Univ. Press. <https://doi.org/10.1017/CBO9781316219706>
- Powell, Kenneth. 2010. 'The Living Museum'. In *Sainsbury Centre for Visual Arts – Foster & Partners*, edited by David Jenkins, 14–89. Munich: Prestel.
- Quinan, Jack. 1987. *Frank Lloyd Wright's Larkin Building: Myth and Fact*. Architectural History Foundation Books 11. New York: Architectural History Foundation; Cambridge, Mass.: MIT Press.
- Reckwitz, Andreas. 2003. 'Grundelemente einer Theorie sozialer Praktiken'. *Zeitschrift für Soziologie* 32(4):282–301. <https://doi.org/10.1515/zfsoz-2003-0401>
- Reh, Sabine, and Robert Temel. 2014. 'Observing the Doings of Built Spaces. Attempts of an Ethnography of Materiality'. Edited by GESIS-Leibniz-Institut für Sozialwissenschaften. *Historical Social Research / Historische Sozialforschung*, Special Issue: Spatial Analysis in the Social Sciences and Humanities, 39 (2): 167–80.
- Rietveld, Gerrit Thomas. 1958. 'View of Life as a Background of My Work'. In *The Work of G. Rietveld Architect*, by Theodore M. Brown, 162. Utrecht: Bruna.
- Rizzoli Communications, Inc. 1984. 'Michel Foucault Interview, "Space, Knowledge, and Power"'. In *The Foucault Reader*, edited by Paul Rabinow, originally published in *Skyline* by Rizzoli Communications (March 1982), 239–56. New York: Pantheon Books.
- Ross, Kristin, and Henri Lefebvre. 1997. 'Lefebvre on the Situationists: An Interview'. Translated by Marie-France Nizet-Sangrones. *October* 79: 69–83.
- Rumpfhuber, Andreas. 2013. *Architektur immaterieller Arbeit*. Vol. 1 kollektive gestalten. Wien: Turia + Kant.
- Rybczynski, Witold. 2011. *The Biography of a Building: How Robert Sainsbury and Norman Foster Built a Great Museum*. New York: Thames & Hudson.
- Sainsbury Center. 2017. 'Rana Begum - Space Light Colour'. Norwich: self-published Sainsbury Centre for Visual Arts. Exhibition Leaflet.
- . 2018a. 'Robert and Lisa Sainsbury Collection'. 2 December 2018. <https://scva.ac.uk/about/collections/robert-and-lisa-sainsbury-collection>.
- . 2018b. 'About the Collections.' 2 December 2018. <https://scva.ac.uk/about/collections>.
- Sainsbury Centre Young Associates, ed. 2017. 'Lie down in the Gallery'. Norwich: self-published Sainsbury Centre for Visual Arts. Booklet.
- Sainsbury, David. 2018. 'Foreword'. In *Superstructure: The Making of the Sainsbury Centre*, edited by Jane Pavitt and Abraham Thomas, 9. Norwich: Sainsbury Centre of Visual Arts, Univ. of East Anglia. Exhibition catalogue.
- Schatzki, Theodore R. 2001. 'Introduction: Practice Theory'. In *The Practice Turn in Contemporary Theory*, 10–23. London: Routledge.

- . 2002. *The Site of the Social: A Philosophical Account of the Constitution of Social Life and Change*. Univ. Park, PA: Pennsylvania State Univ. Press.
- Schatzki, Theodore R., K. Knorr Cetina, and Eike von Savigny, eds. 2001. *The Practice Turn in Contemporary Theory*. New York: Routledge.
- Schmarsow, August. 1994. 'The Essence of Architectural Creation'. In *Empathy, Form, and Space: Problems in German Aesthetics, 1873–1893*, edited by Robert Vischer, Harry Francis Mallgrave, and Eleftherios Ikononou, translated by Harry Francis Mallgrave, 281–97. Texts & Documents. Santa Monica, CA: Getty Center for the History of Art and the Humanities; Distributed by the Univ. of Chicago Press.
- Schmid, Christian. 2005. *Stadt, Raum und Gesellschaft: Henri Lefebvre und die Theorie der Produktion des Raumes*. Sozialgeographische Bibliothek 1. Stuttgart: Steiner.
- Schmitz, Hermann. 2005a. *Der Gefühlsraum. System der Philosophie*. Der Raum, Studienausgabe / Hermann Schmitz ; Bd. 3 Teil 2. Bonn: Bouvier.
- . 2005b. *Der leibliche Raum. System der Philosophie*. Der Raum, Studienausgabe / Hermann Schmitz ; Bd. 3 Teil 1. Bonn: Bouvier Verlag.
- . 2014. *Atmosphären*. Freiburg: Verlag Karl Alber.
- Schneider, Tatjana, and Jeremy Till. 2009. 'Beyond Discourse: Notes on Spatial Agency'. *Footprint* 3 (1): 97–111.
- Schroer, Markus. 2006. *Räume, Orte, Grenzen: Auf dem Weg zu einer Soziologie des Raums*. Suhrkamp Taschenbuch Wissenschaft 1761. Frankfurt am Main: Suhrkamp.
- Scott, Geoffrey. 1914. *The Architecture of Humanism. A Study in the History of Taste*. Boston: Houghton Mifflin Company.
- Sekules, Veronica, ed. 2015. *Art Worlds Social Action: Education and Research 2012–2015*. Norwich: Sainsbury Centre for Visual Arts.
- Semper, Gottfried. 1989. *The Four Elements of Architecture and Other Writings*. Translated by Harry Francis Mallgrave and Wolfgang Herrmann. RES Monographs in Anthropology and Aesthetics. Cambridge: Cambridge Univ. Press.
- Sexton, George S. 2003. 'Exhibition Design at the Sainsbury Centre for Visual Arts'. In *Sainsbury Centre for Visual Arts: 25 Years*, edited by Sainsbury Centre for Visual Arts and Amanda Geitner, 27–31. Norwich: Sainsbury Centre for Visual Arts, Univ. of East Anglia.
- Smith, Richard H., and Penelope Lucas. 2006. 'Summer 2016 - Visitor Survey'. Unpublished visitor survey, Sainsbury Centre for Visual Arts, Norwich.
- Smith, Terry. 2012. *Thinking Contemporary Curating*. ICI Perspectives in Curating 1. New York: Independent Curators International.
- Soja, Edward W. 2011 [1989]. *Postmodern Geographies: The Reassertion of Space in Critical Social Theory*. New York: Verso.
- Sommer, Robert, and Susan Aitkens. 1982. 'Mental Mapping of Two Supermarkets'. *Journal of Consumer Research* 9 (2): 211–15. <https://doi.org/10.1086/208915>

- Strebel, Ignaz. 2011. 'The Living Building: Towards a Geography of Maintenance Work'. *Social & Cultural Geography* 12 (3): 243–62. <https://doi.org/10.1080/14649365.2011.564732>
- Sudjic, Deyan. 1986. *Norman Foster, Richard Rogers, James Stirling: New Directions in British Architecture*. London: Thames and Hudson.
- . 2010. *Norman Foster: A Life in Architecture*. London: Weidenfeld & Nicolson.
- Summerson, John. 1990. 'The Case for a Theory of "Modern" Architecture'. In *The Unromantic Castle and Other Essays*, 257–66. London: Thames and Hudson.
- Thomson, Garry. 1978. *The Museum Environment*. The Butterworth Series on Conservation in the Arts, Archaeology, and Architecture. London: Butterworths.
- . 1994. *The Museum Environment*. Second ed. Butterworth-Heinemann Series in Conservation and Museology. London: Butterworth-Heinemann.
- Thrift, Nigel. 2006. 'Space'. *Theory, Culture & Society* 23 (2–3): 139–46. <https://doi.org/10.1177/0263276406063780>
- Till, Jeremy. 2013. *Architecture Depends*. Cambridge, Mass.: MIT Press.
- Trüby, Stephan. 2016. *Geschichte des Korridors*. Paderborn: Fink, Wilhelm.
- Turner, Alasdair. 2001. 'Depthmap: A Program to Perform Visibility Graph Analysis.' In *Proceedings of the 3rd International Symposium on Space Syntax*, 31.1—31.9.
- Ungers, Oswald M. 1991. 'Das Janusgesicht der Architektur'. In *Architektur 1951–1990*, translated by Ulrike Stopfel, 231–32. Stuttgart: Dt. Verl.-Anst.
- 'University of East Anglia, Norwich; Architects: D. Lasdun & Partners'. 1969. *Architectural Design*, 5: 245–68.
- Vandenberg, Maritz. 1998. *New National Gallery, Berlin: Ludwig Mies van der Rohe*. Architecture in Detail. London: Phaidon Press.
- Vidler, Anthony. 1992. 'Transparency'. In *The Architectural Uncanny: Essays in the Modern Unhomely*, 217–25. Cambridge, Mass.: MIT press.
- Vitruvius Pollio, Marcus. 1914. *The Ten Books on Architecture*. Translated by Morris Hicky Morgan. Cambridge: Harvard Univ. Press.
- Wilkinson, Chris. 1996. *Supersheds: The Architecture of Long-Span, Large Volume Buildings*. Second edition. Butterworth Architecture New Technology. Oxford: Butterworth Architecture.
- Woelk, Imke. 2010. 'Der offene Raum - Der Gebrauchswert der Halle der Neuen Nationalgalerie Berlin von Ludwig Mies van der Rohe'. PhD diss., Technische Universität Berlin.
- Yaneva, Albena. 2005a. 'A Building Is a Multiverse'. In *Making Things Public: Atmospheres of Democracy*, edited by Bruno Latour and Peter Weibel, 530–35. Cambridge, Mass.: MIT Press.
- . 2005b. 'Scaling Up and Down: Extraction Trials'. In *Architectural Design. Social Studies of Science* 35 (6): 867–94. <https://doi.org/10.1177/0306312705053053>
- . 2009a. *Made by the Office for Metropolitan Architecture: An Ethnography of Design*. Rotterdam: 010 Publishers.

- 2009b. *The Making of a Building: A Pragmatist Approach to Architecture*. Oxford: Lang.
  - 2009c. 'Making the Social Hold: Towards an Actor-Network Theory of Design'. *Design and Culture* 1 (3): 273–88. <https://doi.org/10.1080/17547075.2009.11643291>
  - 2010. 'The "Architectural" as a Type of Connector: A Realist Approach to Architecture'. In *The Real Perspecta*, edited by Matthew Roman, 141–45. *Perspecta* 42. Cambridge, Mass.: MIT Press.
  - 2012. *Mapping Controversies in Architecture*. Burlington: Ashgate Pub. Co.
  - 2013. 'Actor-Network-Theory Approaches to the Archaeology of Contemporary Architecture'. In *The Oxford Handbook of the Archaeology of the Contemporary World*, edited by P. Graves-Brown, Rodney Harrison, and Angela Piccini, 121–34. *Oxford Handbooks in Archaeology*. Oxford: Oxford Univ. Press. <https://doi.org/10.1093/oxfordhb/9780199602001.013.003>
  - 2017. *Five Ways to Make Architecture Political: An Introduction to the Politics of Design Practice*. New York: Bloomsbury Academic. <https://doi.org/10.5040/9781474252386>
- Zevi, Bruno. 1957 [1948]. *Architecture as Space: How to Look at Architecture*. Edited by Joseph A. Barry. Translated by Milton Gendel. New York: Horizon Press.



