

### Epistemic Activities, Schooling and Parenting Styles: A Case Study in French Guiana Rural Contexts

Ailincăi, Rodica; Alì, Maurizio; Alby, Sophie

Veröffentlichungsversion / Published Version

Zeitschriftenartikel / journal article

#### Empfohlene Zitierung / Suggested Citation:

Ailincăi, R., Alì, M., & Alby, S. (2018). Epistemic Activities, Schooling and Parenting Styles: A Case Study in French Guiana Rural Contexts. *Contextes et Didactiques*, 12, 60-84. <https://nbn-resolving.org/urn:nbn:de:0168-ssoar-62763-2>

#### Nutzungsbedingungen:

Dieser Text wird unter einer CC BY-NC Lizenz (Namensnennung-Nicht-kommerziell) zur Verfügung gestellt. Nähere Auskünfte zu den CC-Lizenzen finden Sie hier: <https://creativecommons.org/licenses/by-nc/4.0/deed.de>

#### Terms of use:

This document is made available under a CC BY-NC Licence (Attribution-NonCommercial). For more information see: <https://creativecommons.org/licenses/by-nc/4.0>

## **Epistemic activities, schooling and parenting styles: A case study in French Guiana rural contexts**

**Rodica AILINCAI<sup>1</sup>, Maurizio ALÌ<sup>2</sup> et Sophie Alby<sup>3</sup>**

<sup>1</sup> Université de la Polynésie française – EASTCO (EA 4241)

<sup>2</sup> Université des Antilles, ESPE de Martinique – CRREF (EA 4538)

<sup>3</sup> Université de la Guyane – UMR SEDYL-CELIA (UR 135)

### **Résumé**

Basée sur une approche écologique et interactionniste, cet article présente les résultats d'une recherche menée avec les parents et enfants de quatre minorités de la Guyane française. À partir de l'interrogation sur le lien entre les styles interactifs parentaux et la dynamique de scolarisation de jeunes enfants en Guyane française, deux hypothèses ont été avancées : (1) les interactions familiales sont les manifestations visibles des idéologies éducatives des parents ; un écart important entre les interactions familiales et scolaires pourrait influencer l'adaptation scolaire de l'enfant ; (2) les styles interactifs parentaux peuvent varier selon la nature des interactions : interactions quotidiennes *versus* à visée d'apprentissage. La population de l'étude concernait 16 dyades, appartenant à quatre groupes distincts : les Teko, les Aluku, les Laotiens et les Haïtiens de Guyane française. Le recueil des données a été réalisé par des observations in-situ (pour l'étude 1) et par des enregistrements vidéo (pour l'étude 2). Le codage et les analyses ont mobilisé les outils de la pragmatique conversationnelle et des observations anthropologiques. Les résultats, basés sur le modèle des styles interactifs d'Ailincal et Weil-Barais (2007), suggèrent que les styles éducatifs des parents sont influencés par l'écosystème socioculturel et que le comportement des parents, notamment quand il s'agit de la réussite scolaire, est profondément influencé par les logiques, les stratégies et les idéologies éducatives « globalisées ». Le contexte interactionnel influence le style interactif parental : ainsi, les styles interactifs quotidiens apparaissent comme très contrastés entre les communautés observées, alors que les styles interactifs épistémiques (liés aux situations à visée d'apprentissage) semblent mobiliser les mêmes catégories comportementales chez tous les groupes étudiés.

### **Mots clés**

Conduites éducatives, minorités, multiculturalisme, parentalité, styles éducatifs.

### **Abstract**

Based on an eco-systemic approach, this article presents the results of an experimental survey among parents and children of four ethnic and cultural French Guiana minorities. Moving from questioning the existence of a correlation between interactive parenting styles and the schooling achievements of young children in French Guiana, we propose two hypotheses: (1) family interactions are visible manifestations of parents' educational ideologies; a large gap between family and school interactions could influence the child's school adaptation; (2) parenting interactive styles may vary depending on the nature of the interactions: daily versus learning interactions. Our sample concerned 16 family dyads belonging to four distinct groups: the Teko, Aluku, Laotians and Haitians of French Guiana. Data collection was performed by in-situ observations (to explore the first hypothesis) and video recordings (for the second hypothesis). We used coding and data analysis tools belonging to both conversational pragmatics and the anthropological methodological tradition. The results, based on the interactive styles model proposed by Ailincal & Weil-Barais (2007), suggest that parents' educational styles are influenced by the socio-cultural ecosystem and that parental behavior, especially when it is related to school success, is profoundly influenced by "globalized" logics, strategies and educational ideologies. The interactional context influences the interactive parental style: as such, the daily interactive styles appear as very mixed between the observed communities, whereas the interactive epistemic styles (related to the learning situations) seem to mobilize the same behavioral categories in all the groups we studied.

### **Keywords**

Educational styles, educative performances, minorities, multiculturalism, parenting.

## 1. Introduction and general research context

Several research activities suggest that the social context (family origins, economic status, cultural stimuli and religious beliefs) strongly influences the performances and achievements of pupils and students (Duru-Bellat & Van Zanten, 2006; Meuret & Morlaix, 2006; Murat, 2009). The influence of family factors on school performance has been widely studied and some large-scale international research programs<sup>1</sup> are especially focused on that: their results confirm that the school failure of pupils is tendentially associated with the disadvantaged socio-economic status of their families (OCDE, 2014).

These tendencies are also evident in France (among other developed countries around the world), as highlighted by some recent reports of the Organization for Economic Cooperation and Development (OCDE, 2015), and especially in its overseas territories (its former colonies), such as French Guiana (Baccaini & *al.*, 2014). Actually, the postcolonial heritage has fragilized the socio-economic panorama, and the access to the “global village” has contributed to complexifying the local multicultural and plurilingual environment. In addition, the typical “top-down” decision-making process and the centralized standardization inherent to educational policies in France has fueled the emergence of difficulties faced by pupils and students of overseas schools (Ali, 2016). There are many indications of these difficulties: for example, only one in three students have a high school diploma (32.2% success rate) and 45% of students leave the school system without a diploma at all (OCDE, 2015). Nevertheless, statistical data may be influenced by multiple interrelated factors such as the overrepresentation of allophone pupils among French Guianese students (28% of pupils come from a migration background), the presence of several indigenous minorities (who perceive French as a schooling language but not as their mother tongue), or the socio-economic difficulties encountered by families living in isolated areas (e.g. unemployment, distance from school, digital gap, etc.) (Bayart, Dorelon & Hurpeau, 2013).

School failure may also be influenced by the existence of an “interactional gap”, a *hiatus* separating the interactional habits of some children (within the domestic environment) and the interactional styles of their teachers (at school). The relevance of this hypothesis has been reinforced by previous studies on the importance of training teachers to perform in an effective way and to develop “interactional skills” in plurilingual and multicultural contexts (Alby & Launey, 2007). Other studies have confirmed that teachers working in remote locations (most of whom are new to the profession) in metropolitan France<sup>2</sup> or its overseas territories often feel helpless when they take up their duties, mostly because of that “interactional gap” with their students, the student’s families or the local colleagues (Ali, 2016).

### ***Problem statement and hypothesis***

The research presented in this article focuses on the latter hypothesis and advances the following question: how much are interactive parenting styles related to the socio-economic ecosystem, the social history of families and communities, and finally, the schooling dynamics?

---

<sup>1</sup> As is indeed the case for the Program for International Student Assessment (PISA) managed by the Organization for Economic Cooperation and Development (OECD).

<sup>2</sup> The French mainland, or the part of the French territory located on the European continent.

In our hypothesis, educative interactions are the visible manifestations of the parents' educational strategies and educative ideologies. As a corollary, a significant gap between family and school interactive practices could influence the child's school adaptation. In order to verify our first hypothesis, our first goal aimed to identify the interactive styles of four minority groups living in French Guiana with cultural and linguistic specificities more or less distant from the school culture and the language of schooling, French.

As a second hypothesis, we suggested that parenting interactive styles and parenting practices could vary depending on the nature of the activity. In order to verify this second hypothesis, we studied the stability vs the variability trends of interactional styles among our samples. We observed two distinct educational situations: an ordinary domestic activity and an activity aimed at learning.

Our research, based on a descriptive and exploratory approach, was conducted from a comparative perspective. As usual in comparative education studies (especially when combined with an anthropological approach), the comparison does not use the notion of a "norm" under any circumstances: we adopted this approach to facilitate the detection of peculiarities and specificities that differ from mainstream standards (Groux, 1997; LeVine & New, 2008). The "global village" facilitates the diffusion of multiple developmental models and parents' interaction styles that are often adjusted (according to local habits and family traditions) to the child's needs and adapted to the social and physical environment in which the child is growing up (Ailincai & Weil-Barais, 2013). In this article, the description of family interaction patterns is suggested as a possible variable in early childhood school adjustment.

## **2. Theoretical considerations**

A growing number of scholars suggest that adult educational practices may be considered as intermediate variables between the social environment and child's performance at school (Bloom, 1964; Pourtois, 1979). The link between the child's immediate environment and the sociocultural context has been widely discussed by ecosystemic theories on the one hand and sociocultural theories on the other. In psychology, ecosystemic theories of development have therefore emphasized the role played by the microsystems of primary socialization, *idest* the people who directly care for the child (family members, teachers, etc.), as well as the impact of the upper levels of the system in which it is embedded (the extended family, the educational and social community, the social group, the "global village").

Several studies have shown that the way parents exercise their role has an impact on child development and academic success (Cho, Weil-Barais & Hoel, 2008; Dearing & *al.* 2006; Lahaye, Pourtois & Desmet, 2007; Spoth, Randall & Shin, 2008). In addition, other researchers have attempted to identify the characteristics of the intervention methods and parental attitudes that determine children's good physical, cognitive, emotional and social development (Barocas & *al.*, 1991; Martin, Ryan, Brooks-Gunn, 2007; Steinberg & *al.*, 1992; Weil-Barais & *al.*, 2008).

According to Bronfenbrenner's famous developmental model (1979), the child's cognitive development is influenced by the different interrelated social environments and systems. In line with sociocultural theories, most of which are influenced by Vygotsky's ideas (1934), children can learn better when they are involved in interactive activities. According to Vygotsky's "zone of proximal development" model, children's acquisition of knowledge and

new skills is enhanced when a more skilled person facilitates their learning by using gestures, artefacts and language simplifications (or *scaffolding*).

A review of recent international educational literature on teaching practices shows that the main determining factors of fundamental learning and behavioral disorders are family practices (Khanna & Kendall, 2009) and parent-child interaction patterns (Feinberg & *al.*, 2010). In addition, some research highlights the impact of parental education practices on school success and the fact that practices vary according to the gender of the child (Deslandes & Cloutier, 2005; Potvin & *al.* 1996). Pourtois notes that family realities (e.g. behavior, attitudes, personality traits and the intellectual aptitude of parents, status and social environment) can explain more than 84% of the variance in learning achievement (Pourtois, 1979).

Finally, our previous works also confirmed the role that family educational practices can play in bi/plurilingual school environments (Ailincăi, Jund & Ali, 2012; Ali & Ailincăi, 2013).

### **2.1. Interactive styles in scientific literature**

Early works on parenting (Baldwin, 1948; Becker, 1964) consensually favored dichotomous models (autonomy / control, warmth / hostility, restriction / permission) to describe parenting practices. In 1971, Baumrind introduced the notion of interactive styles and, breaking with the traditional binary model (authority / permissiveness), he introduced a third style (democratic, which reconciles the two previous ones, Baumrind, 1971; see also Baumrind 1978, 1989). He identifies educational practices of the “authoritarian” type (characterized by high levels of control and low support), then educational practices of the “authoritative” or “democratic” type (characterized by high levels of control and support), and, finally, “permissive” educational practices (characterized by weak control and high support). Baumrind’s research suggests that the authoritative style (high control and support) promotes the best development of the child. The triptych model of parenting practices has been adopted by other researchers, especially Lautrey (1984) and Kellerhals and Montandon (1991), who studied the influence of social belonging on parental behavior. Following Baumrind, Maccoby and Martin (1983) proposed a typology based on four parenting styles : (1) the democratic style (child-focused, with a normal level of parental control); (2) the authoritarian-restrictive style (parent-focused, with a high level of parental control); (3) the indulgent style (child-focused, with a low level of parental control); and (4) the indifferent style (parent-focused, with a low level of parental control).

Concerning parent-child educational interactions, Ailincăi & Weil-Barais (2007, see also Ailincăi, 2005) also consider four interactive styles:

1. the directive one (the parent imposes the procedure, delivers an acquaintance, specifies the procedure and cares about the child’s success as well as the child’s attention paid to the activity);
2. the suggestive style (the parent questions the child about the actions to be taken, encourages the child to produce explanations, makes the child active, asks for the opinion of the child, asks to be counseled, helped);
3. the empowering style (the parent lets the child discover, supports him in his successive trials, promoting trial-and-error learning);
4. the dysfunctional style (characteristic of an individualistic approach, when the interaction is not functional with the task).

We consider this last model to be the main theoretical framework of this research because, like Ailincăi & Weil-Barais, we observed the interactive styles in an experimental situation of parental support of an activity with a learning focus.

Finally, it should be noted that several studies in the field of parenting practice agree that “soft” educational practices (including democratic practices that value the child’s initiative, curiosity, critical thinking, originality, and respect for others) are the most effective in terms of the child’s moral and cognitive development, regardless of social and cultural background (Lautrey, *ibid.*; Baumrind, 1989).

## **2.2. Parenting styles and the cultural variable**

The cultural factor has been regularly taken into account in several research works about the effectiveness of educational styles on child development and schooling. While Baumrind’s (1989) researches identified the democratic style as most favorable to child development, other researches (Chao, 1994; Dornbusch et al., 1987; Lin & Fu, 1990), showed that this style is not effective for children belonging to several Asian cultures. In the case of the latter, academic success seems more related to authoritarian educational logics. In their research comparing the educational styles of Puerto Rican and US families belonging to the working and middle classes, Harwood, Miller & Irizarry (1995) found differences in parental behavior according to the respective cultures as well as cultural differences in the moral judgement associated with parental values (mothers in the United States, for example, favor qualities such as independence, self-confidence and personal success, regardless of social background). In the same vein, Fontaine’s study (1990) notes that parental authoritarianism does not have the same connotation in Portugal (where it is not an obstacle to manifestations of tenderness or affection), in the United States or in other European countries. Finally, our previous work on the Amerindian communities of French Guiana (Emerillon, Wayapi, Wayana), revealed that the empowering activities are paradoxically often associated with disjointed interactions (Ailincăi, Jund & Ali 2012, Ali & Ailincăi, 2013). On the other hand, we discovered that disjointed interactions did not seem favorable to the discovery of new knowledge in a more urban context (Ailincăi, 2005).

## **2.3. The quantitative analysis of interactive styles**

Usually, educational styles are evaluated by using self-administered questionnaires, such as Block’s Parenting Questionnaire (1985); the Rickel and Biasatti model (1982); the Steinberg, Lamborn, Dornbusch & Darling (1992) and the Epstein, Connors and Salinas (1993) parental-style measurement instruments, as well as the ECEP parenting skills scale of Terrisse and Larose (2000). Nevertheless, the accuracy of data collected by a self-administered survey or in interviews is often questioned with respect to certain biases concerning the discrepancy between “what I say and what I do”: the declarative and the actual practices (Deslandes, 1996; Kochanska Kuczynski & Radle-Yarrow, 1989; Dekovic, Jenssens & Gerris, 1991).

With regard to “effective” practices, the identification of interactive styles is done by analyzing parental behaviors observed in-situ or filmed, using a set of tools borrowed from linguistics, psycholinguistics and conversational pragmatics to code the data such as the list of attributes and behavioral functions used by Pourtois (1979); the analysis based primarily on the task announced by the parent (François & Weil-Barais, 2003); behavioral categories and subcategories of verbal and non-verbal acts (Ailincăi, 2005); or the systematic observation with behavior sampling (Ali, 2016).

Finally, Ailincăi & Weil-Barais (2007) identified and classified the interventions they recorded in behavioral categories based on existing taxonomies, particularly the Adams criteria (1972), the behavioral functions of De Landsheere and Bayer (1969) and the categorization proposed by Pourtois (1979).

The grouping of verbal and non-verbal interventions into behavioral categories and subcategories and then into interactive styles is presented in Table n.1.

**Table 1: Verbal and non-verbal acts as manifestations of interactional styles (based on Ailincăi, 2011 and Ailincăi & Weil-Barais, 2007a)**

<b>Interactional style</b>	<b>Action</b>	<b>Code</b>	<b>Example</b>
<b>Directive</b>	<b>Imposition</b>	V1	Requests an explanation, a description, an answer, help
		V2	Requests an action (by imposing it); gives an order; prohibits
		V3	Requires attention (or demands it); imposes behaviour
		V4	Provides information, explanations, answers; describes
		V5	Offers help; proposes an action (by imposing it)
		N1'	Indicates an action, an object, a phenomenon (by imposing them)
	<b>Negative feedback Handling</b>	V11	Disagrees, refuses, evaluates negatively
		N3	Performs the action for the child
		N4	Imposes manipulation; imposes assistance; prevents action by the child
<b>Eye contact</b>	N8	Looks at the child with presence of control; applies	
	N9'	normative behavior by nodding	
<b>Suggestive</b>	<b>Development</b>	V6	Requests anticipation (e. g. "if you want something to happen, what should you do?"); request for formalization of the observation ("what happened?"). Requests confrontation between the prediction and the observation ("is that what you expected?")
		V7	Provides clarification, information; suggests help; gives advice; reminds; answers the child's questions
		V8	Proposes an action, recommends
		V9	Encourages; reassures
	<b>Positive feedback Handling</b>	V12	Evaluates positively; approves;
		N2	Handles to demonstrate, to create the conditions for the child's success, to help the child
		N1	Indicates an action, an object, a phenomenon (by suggesting them)
		N5	Suggests complementary solutions to the ones selected by the child (by handling)
<b>Empowering</b>	<b>Development</b>	V10	Announces empowerment through performative verbs
		V10'	Recommends, suggests empowerment
	<b>Positive affectivity</b>	N10'	The parent is caring, hugs the child, displays tender gestures
	<b>Looking/ mimicking</b>	N7/9	Looks at the child with kindness, laughs or smiles.
<b>Disjointed</b>	<b>Handling</b>	N6	Disjointed handling (independent individualistic approach: everyone does their own thing)
	<b>Negative affectivity</b>	N10	Leaves it to the child, s/he is detached from what the child is doing, ignores the child's actions, or s/he is interested in another task

### 3. Methodology

To answer our research question, and in particular to discuss the interactive styles according to the family context and the interactional context of the activity, we conducted two separate experiences with the same sample: the first one aimed to observe parent-child interactions in daily family activities, whilst the second one aimed to observe parent-child interactions during a scientific and technical activity proposed by the researcher (Figure n.1).

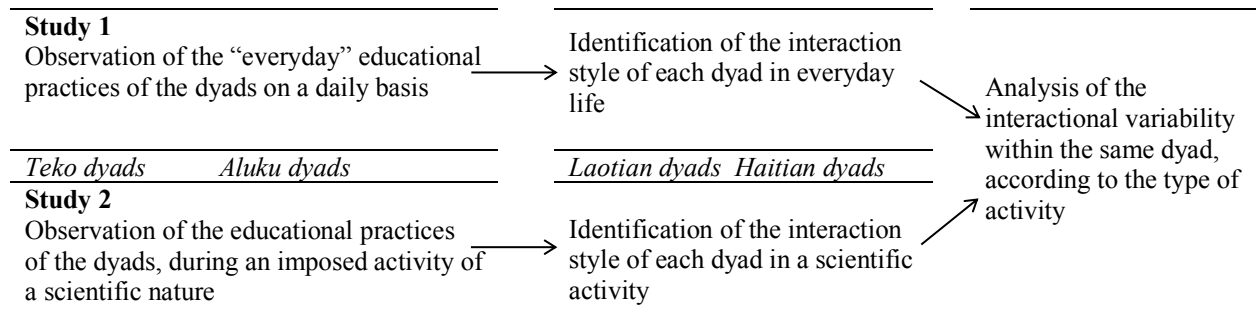

**Figure 1: Identifying the interactional styles: the data analysis protocol**

#### 3.1. The sample

The 16 parent-child dyads participating in our survey belonged to four communities with a peculiar cultural identity living in French Guiana: Teko, Aluku, creole-speaking Haitians and Laotians. Teko and Aluku live in the Amazon sector of French Guiana, in the rainforest, whilst the last two groups (Laotians and Haitians) live in the coastal sector, near the urban centres. Children participating in the study were from 6 to 8 years old and their parents were all aged from 30 to 36 years. All parents attended primary school, some attended middle school but none of them attended high school.

Teko communities, along with the Wayãpi, Kali’na, Palikur, Wayana, Lokono and Apalai, form the Amerindian population of French Guiana, and represent about 4% of the Guianese population (Archimbaud & Chapdelaine, 2015). Teko families participating in our study lived in Camopi, a village on the Oyapock river (bordering with Brazil). The selected dyads spoke Teko, an Amerindian language belonging to the Tupi-Guarani linguistic family.

The Alukus (or Bonis), along with the Ndjuka, Paramaka and Saramaka, are the main Guianese Businenge (or Maroons) groups and live along the Maroni River, especially around three main villages: Apatou, Papaïchton and Maripasoula. According to the French National Institute of Statistics, the INSEE, Alukus represent about 4% of the Guianese population (Gragnic & Horatius-Clovis, 2014). The four dyads participating in our survey lived in Maripasoula (three dyads) and Apatou (one dyad) and they spoke Aluku, a Creole language with an English lexical base.

The Laotian dyads lived on the Guianese coast: two dyads in the village of Macouria and two in Roura). Their community migrated from Laos during and after the Vietnam War and now represents about 1.5% of the population (Tavernier, 2012). The dyads participating in the survey were enjoying a rather favorable economic situation and a middle-class comfort level (i.e. a large house, several multimedia devices, cars, etc.) but only one mother was employed after successfully completing middle school studies, whilst the other parents were farmers and never attended middle school.



People of Haitian origin living in French Guiana represent about 9% of the population (Tavernier, 2012). The first Haitian immigrants arrived in French Guiana in the 1970s for humanitarian reasons. Their first language is Haitian Creole, a Creole language with a French lexical base (Laëthier, 2007). For the four dyads participating in the study, the parents were born in Haiti whilst the children were born in French Guiana. Parents of two dyads completed compulsory studies in Haiti (primary and middle school), whilst two others stopped studying during middle school.

Guiana indigenous and ethnic communities living in remote locations, such as Teko and Aluku people, have limited language proficiency in French and they use the national language only at school or to interact with the public administration. However, Laotians and Haitians who live near the main Guianese urban centers are fluent in both their native and French languages. Among those communities, we noticed some shared peculiar linguistic habits that we reported in previous publications: we observed, for example, that grandparents speak to children and grandchildren mainly in their first language; parents, on the other hand, even if adopting the mother tongue in everyday interactions, often use French, while children, conversely, use the French language more often than the mother tongue of their parents (Hidair & Ailincal, 2014; Ali, 2016). In our opinion, these linguistic habits are deeply interrelated with a plurilingual context where some languages are perceived as hegemonic, others as functional and others as a form of revindication. Also, they are linked with the perception of the sociocultural changes that occur in the transition from one generation to the next (when young people seem more detached from their past) and the valorization allowed for some languages (and negated for others) as forms of “immaterial cultural heritage”.

### **3.2. Data collection**

Each goal was associated to a specific method of data collection:

- for the first study, we used ethnographic *in situ* observations, aimed to identify an interaction pattern in the family life of each sociocultural group considered;
- for the second study, we used systematic observations based on behavior sampling during experimental activities of a scientific nature (reproducing a school situation). Activities were filmed with the aim of facilitating the behavior sampling and the transcription of verbal and no-verbal exchanges.

#### *3.2.1. Study n.1: Daily interactional dynamics*

The first study concerned interactional dynamics in educational situations related to everyday family life: observations were carried out *in-situ* based on the model of participant observation over a period of two hours over two afternoons (one hour on a Monday afternoon and one hour on a Thursday afternoon).

Synthetically, our protocol required the following from the observers: (1) The completeness of the facts. To facilitate the fulfillment of this requirement, we chose to solicit observers familiar with the observation field, including postgraduate students, belonging to the observed families; students were trained in the data collection protocol. (2) The accuracy of the data. The duration of the observation was limited to two hours (during two observation sessions of one hour each), in a fixed perimeter, the house; (3) The focus on the interventions of two, and only two, agents, the parent and the child; (4) The relevance of the facts observed (observers were allowed to question the interactants in case of uncertainty concerning the meaning of their actions or their verbal exchanges). Participants were informed about the objectives of the

research and the role of the observers (“I would like to see how *X* [the child’s first name] is preparing for tomorrow’s school day”). There was no imposed activity during the two hours of observation.

To facilitate comparative analysis, we organized the data collected during the aforementioned in-situ observations into a behavioral grid inspired by the Ailincăi & Weil-Barais (2007) interactive style model, which allowed us to capture parental behavior every three minutes.

**Table 2 : Observation grid of parental behaviour**

	Minutes		
<b><i>Parenting interaction</i></b>	1-3	4-7	...
The “directive style” includes verbal and non-verbal injunctions imposed on the child. It provides normative and negative feedback on the child’s behavior.			
The “suggestive style” includes interactions that stimulate children’s verbal and nonverbal productions (requests for clarification, assistance, advice, encouragement, reminders, and positive feedback, actions explicating verbal responses).			
The “empowering style” is associated with interactions promoting children’s autonomy, while parents maintain an attentive posture to the development of the tasks assigned to the child.			
The “disjointed functioning style” includes non-collaborative and negligent exchanges between parent and child (e.g. independent individual activities).			

The grid made it possible either to simply check the behavioral categories observed in the field or to record uncertain interventions (or the most significant situations). The overall interaction style of a dyad is characterized by the proportion of exchanges corresponding to each style.

### 3.2.2. *Study n.2: Interactional dynamics in experimental situations*

The second study was aimed at identifying dominant interactional styles in experimental situations. Data were collected through video recordings and, prior to the recordings, all the subjects participating in the study were asked to fill in and sign a consent form. The experimental protocol consisted of a systematic observation of a scientific and technical discovery activity, chosen for its academic and attractive nature, involving the parents and their children. The difficulty level of the activity was adjusted to allow parents to have an active role and to be able to support effectively their children. As demonstrated by the seminal works of French anthropologist Claude Lévi-Strauss (1962), the observation of scientific activities has an advantage in that scientific explanations are essentially transcultural in nature, going beyond cultural particularities (even though every culture assigns a different value to the factors involved in a scientific problem). However, the problem-solving tasks proposed during the experimental activity were fundamentally dissimilar to everyday routines and essentially based on a typical school procedure, with the aim of studying the variability of the interaction style within the same dyad (between a two-poles-continuum: domestic vs. scholastic activities).

According to the protocol, for every dyad the first instruction given to the child was: “Try to make the bulb light up with this material at your disposal” (see Figure 2a). Observers told the parent that s/he could help their child if s/he wanted to.

The second instruction was: “Introduce this switch into your circuit and try to say what its function in the circuit is” (see Figure 2b). The same instructions were repeated to the parents.

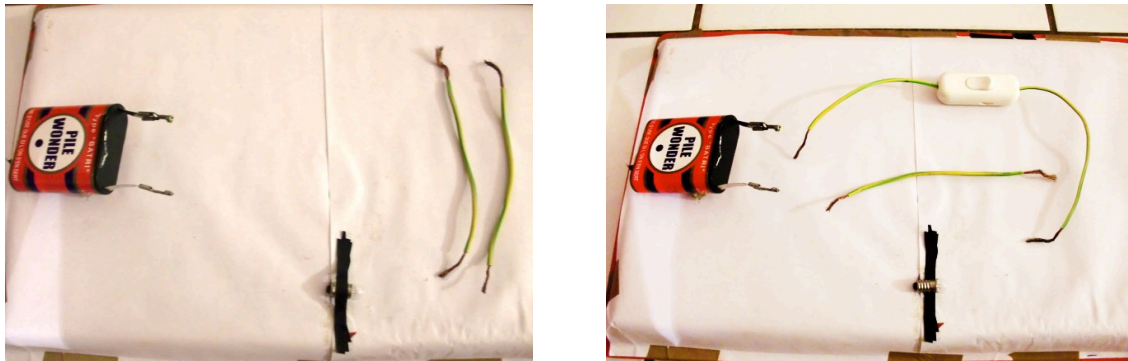

**Figures 2a and 2b: Material made available to the child for the experimental activity**

Responses were analyzed and classified using as a reference the standard response presented in Box 1, based on a definition of “electric circuit” widely accepted by scholars.

---

Instruction 1 (to light up a bulb with a battery):

The two terminals of the battery are the positive (+) and negative (-) terminals. The two terminals of the bulb are the stud and the base. To switch on the bulb with the battery, one of the battery terminals must be connected to the bulb base and the other to the bulb terminal. Thus, we obtain a closed circuit and the bulb lights up.

---

Instruction 2 (the role of the switch in an electrical circuit):

In an electrical circuit, the switch controls the closing (or opening) of the circuit and it allows (or not) the electrical current to flow to the bulb (and to switch on the light).

---

**Box 1: Concepts covered by the experimental activity**

The activity lasted between 7 to 12 minutes, depending on the dyads. For the third and final task, every child was requested to draw, and explain in a graphic way, the experience (see Figure 3).

Instruction n. 3

<p>Sheet 1: Connect the bulb to the battery so that the bulb lights up.</p>	<p>Sheet 2: Name each element of the electrical circuit and indicate whether the circuit is “open” or “closed” and therefore, whether or not the bulb lights up.</p>

**Figure 3: Summary sheet of instruction n.3**

The films we recorded during the second phase of our study were transcribed according to the ICOR convention (ICAR, 2013) [an extract from the transcription convention, with the main code is presented in Box 2]

Excerpt from the ICOR convention (ICAR, 2013):		
"/" intonational increases	"/"/" strong increases	(()) description
"\" intonational falls	"\\\\" major falls	" = "immediate sequence
":::" depending on the elongation	TRA: translation	COM: commentary
(01.58) prolongation of the round	() non-verbal description	

**Box 2: Excerpt from the transcription convention, with the main codes**

The transcripts were coded using the grid proposed by Ailincăi & Weil-Barais (2006), previously presented in Table n.1. The code assigned to parenting interventions took into account the main descriptors of the interaction: (1) the behavior modifications linked to the content (the “message”) of the exchange; (2) the child’s response; (3) the behavior of emotional importance.

Video recordings of the interactions were coded with a half-second accuracy interval for all verbal and non-verbal interventions or simultaneous interventions (e.g. verbalization and gestures). Associating every observed “action” to an interactional style enabled us to identify an interactional pattern (and a dominant interactional style) for each dyad.

Actually, this strategy allowed us to observe the distribution of interactional styles in the framework of an experimental situation, providing a more sensitive description of parents’ methods of intervention than an overall characterization of the interaction, based on participant observations.

**4. Results and data analysis**

The data collected during our fieldwork in French Guiana allowed us to describe and determine the tendencies of the parental behavior within the four cultural communities we studied. Two main objectives were reached:

- Firstly, for each of the four communities, we were able to determine the dominant parenting style in the daily context and during everyday activities;
- Secondly, we were able to determine the dominant interactional style in experimental situations (perceived by parents as “pseudo scholastic” or similar-to-school activities).

**4.1. Characterization of parental behavior in the daily context**

*4.1.1. Interactional styles of Teko dyads*

For the four Teko dyads participating in our study, the parents’ behavior showed a dominance of empowering and disjointed interaction with their children. Indeed, the summary of the observations revealed several interventions recommending or enabling children’s empowerment to “discover the knowledge”.

Despite the cultural differences, all the dyads participating in the study showed similar circadian cycles, probably due to the fact that all of them are integrated in a similar rural context and that the school acts as a “normalizer” according to its “official” rhythm. Furthermore, we did not record relevant differences in daily routines between the four dyads and, in all cases, observed children who had the afternoon off without worrying about school.

Our ethnographic survey confirmed that, when at home, children are generally involved in three main activities: playing with their peers, participating in adult-driven activities and helping in domestic tasks (especially the young girls). Domestic tasks are a privileged situation for observing significative parent/child interactions. We observed, for example, that:

- for dyads 1 and 4, children spontaneously participated in activities initiated by their mothers (e.g. cooking cassava) without being asked to help. Observers noted the absence of positive rewards or feedback from the parents, as well as the absence of punishment when children failed their tasks;
- the mother of dyad 3 was interested in the child's activity (for example, she changed the knife with which her daughter peeled the cassava) but both failures and successes were ignored;
- the mother of dyad 2 was helped by her daughter to prepare the meal in the hut; they worked together without exchanging. The context was characterized by the absence of constraint and permissiveness.

Finally, in our sample, children were generally allowed to choose what they wanted to learn (e.g. basketry, cassava cultivation, basic hunting or fishing skills). Activities inside the hut were characterized by empowering interactions; however, the activities in the nondomestic part (the "public area") of the village were characterized by a disjointed style instead.

#### *4.1.2. Interactional style of the Aluku dyads*

The four dyads participating in our study belonged to traditional Bushinengue communities where mothers had a primordial role in the education of their children; for two dyads, mothers were assisted by their brothers and sisters in the education of their children (the father was out of the home for most of the time); for the third dyad, even though the father was not living with his child, he showed concern for the education of his progeniture (nevertheless, all relevant family decisions belonged to the mother); and for the fourth dyad, the father lived permanently with the family. As in Teko communities, Aluku children enjoyed great freedom, living at the rhythm of their needs (i.e. playing, eating, drinking, sleeping), while being subject to strict domestic rules of obedience (concerning, for example, the performance of certain household tasks or the care for younger siblings, etc.). Observing the four dyads, the standard interactional style shown by Aluku parents is a blend of empowering, directive and slightly disjointed interactions. However, particularities were noted from one dyad to another:

- the dyads n.1 and n.3 were characterized by more impositions and negative feedback than the two other dyads;
- the second dyad interacted with numerous empowering interventions associated with some directive actions (but no disjointed interactions were observed);
- the fourth dyad registered a high amount of positive feedback and no disjointed interactions.

In general, the directive manners of the parents (alternating between empowerment and severity), combined with the liveliness of the children, gave the interaction a restless, talkative, noisy, tumultuous atmosphere. Some scholars, observing the parental habits of Aluku families, highlighted the brutality of their educational style (Hurault, 1965).

#### *4.1.3. Interactional styles of Laotian dyads living in French Guiana*

Among members of the Laotian diaspora in French Guiana, children are introduced to the Laotian culture and language by their parents and grandparents. When at home, they always speak Laotian and often listen to Laotian or Thai music, not to mention that their food is also almost exclusively based on Laotian gastronomy. Parents make explicit demands in terms of expectations of success in school; children are pressured to achieve excellence when at school and, conversely, they are reprimanded for unsatisfactory results.

Grandparents are very involved in the education of the children, speaking to them in Laotian and teaching them the customs and traditions of their country of origin. Mothers seem more involved in their children's education than the fathers. Also, we observed that:

- for dyad n.1, the mother's interventions were mostly suggestive and directive. Learning situations focused mainly on household tasks. Interventions linked with schoolwork were mostly suggestive;
- for dyad n.2 and n.3, the interventions were associated with suggestive and empowering interactions, with some acts of imposition;
- in the fourth dyad, interventions were mostly empowering but, when talking about school and homework, they became directive.

The overall description of these four dyads shows a reserved, undemonstrative affectivity. The parents are very concerned by education issues that are often associated with both a suggestive style of knowledge transmission and directive interventions to clearly define the parental expectations. During our observations, we never recorded any disjointed behavior.

#### *4.1.4. Interactional styles of Haitian dyads, living in French Guiana*

For the four selected dyads, the children we observed were bilingual in Haitian Creole and French; all were correctly enrolled in compulsory schooling. All parents declared that they were concerned by school issues, even if they were not able to help their children in school activities. The family environments of the four observed Haitian dyads were animated by the television which was switched on continuously, even when no one was watching. In addition, when doing their homework, the children kept glancing at television programs. Parental interventions were mostly directive and disjointed, with some suggestive and empowering verbal exchange. We observed, for example, that:

- the mother of dyad n.1 was rather directive (she reprimanded her daughter four times about her school homework) and disjointed (once the books were on the table, she never intervened, remaining preoccupied with household chores);
- for the second dyad, the household tasks were linked to empowering interventions but the preparation of homework was linked with mostly directive and disjointed interventions;
- dyad 3 registered a high number of suggestive interventions but, when the television was on, they became directive;
- for dyad n. 4, homework issues were associated with mostly directive interventions.

The summary of observations highlights an overrepresentation of directive style interactions as a form of behavior regulation (when parents, for instance, assist their children with homework) and a general predominance of disjointed style interactions. Some positive feedback was noted, generally linked to the positive school performances of the children.

#### 4.2. Characterization of parental behavior in an experimental situation

The coding of verbal and non-verbal interventions (according to the analysis grid presented in Table 1) enabled us to classify parental behavior and to present the structure of the interaction style pattern for each parent (see Figure 4).

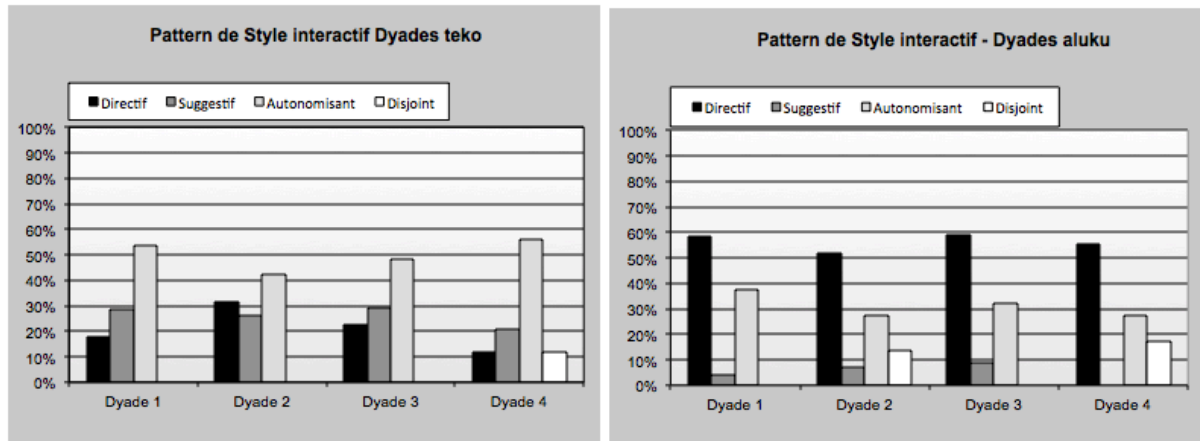
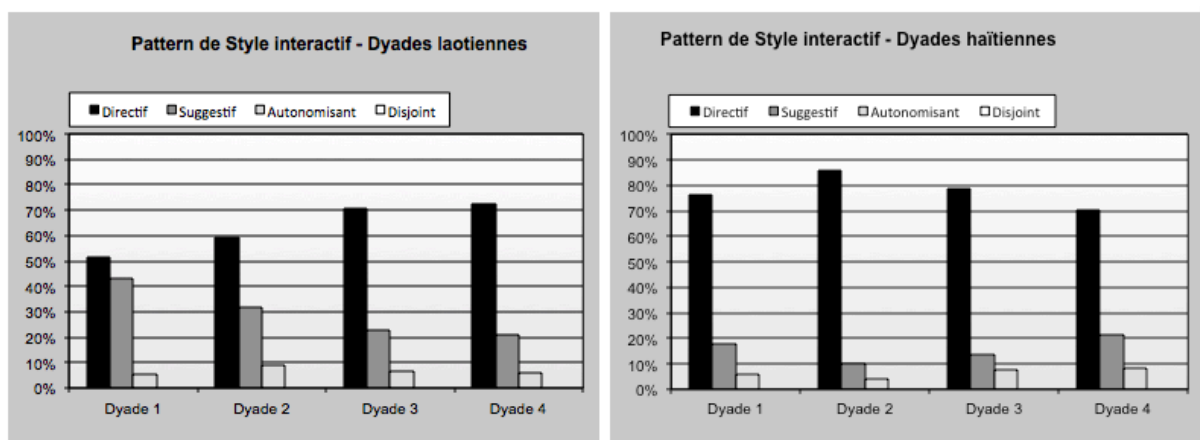

**Figure 4: Layout of the interactional styles of the Teko and Aluku dyads (directive/directif, suggestive/suggestif, empowering/autonomisant and disjointed/disjoint)**

Concerning the Teko and Aluku dyads, we observed that:

- the four Teko dyads showed a dominance of empowering interventions, similarly to their daily style; however, disjointed interventions - which are very present in spontaneous behavior – seem to disappear in favor of more directive and suggestive interventions;
- conversely, the patterns of the Aluku dyads present a directive dominant with a significant number of empowering interventions. In experimental situations, Aluku dyads seem to reproduce their daily style (a blend of empowering and directive interventions, but with a directive dominant). The suggestive style is not present and disjointed interventions are negligible.

Concerning the dyads belonging to the Laotian and Haitian immigrant groups, the directive style is largely predominant. Laotian parents seem to be more inclined to suggestive interactions than their Haitian homologues (see the individual variations in Figure 5).



**Figure 5: Layout of the interaction styles of the Laotian and Haitian dyads (directive/directif, suggestive/suggestif, empowering/autonomisant and disjointed/disjoint)**

All 16 dyads from our sample showed a preponderance of directive interactions. In all cases, the transcripts of our observations highlighted the large number of non-verbal actions of the N3 type (performing/handling the action in place of the child). However, a detailed reading of the transcripts reveals differences between the sociocultural groups we observed:

- the directive style of the Teko parents is made up of a majority of actions of the V5, N1' and N3 type (offers help, proposes an action by imposing / indicates an action, an object, a phenomenon by imposing). An example of an N3 act is presented in Box 2 (an extract from the transcription convention is presented in Table 3).

**Table 3: Excerpt from the transcripts of the exchanges within the Teko dyad 1**

Parent (P) Child (C) Exchanges involving an Observer (O)	Code
C ((the child reassembles everything focusing on the switch))	N3
P ((the mother attaches a connection lead to the + terminal of the battery with a clip and tries to secure the other end to the stud)) (2.48)	
C ((the child closes the circuit which makes a sound)) = = ((the child opens the circuit and waits) (0.11))	
O so tell me why it is ringing /	
C <((in Emerillon)) <u>dede'awudji</u> > ((TRA: you are not speaking)) (addressing his mother) =	V7
P <(( in Emerillon)) <u>ole'awu dokuwadjite</u> > ((TRA: he doesn't know our language\)) (referring to the observer)	
O so/	
C when it's like that (whilst closing the switch)	

- the directive style of Aluku parents is essentially formed by V2 and V3 directive acts (requesting an action (by imposing it), giving an order, prohibiting / requesting attention (or demanding it), imposing behavior); two examples of this type of directive act are presented in Table 4.

**Table 4: Excerpt from the transcripts of the exchanges within the Aluku dyad 3**

Parent (P) Child (C) Exchanges involving an Observer (O)	Code
O Now leave the leads a little and explain to me why it didn't work earlier	V6
P ((the mother looks at her daughter))	N9
C ((COM: the child leaves and runs towards home))	
P <((in Aluku)) <u>pé yé go/ kon ya</u> > ((TRA: where are you going/: come here/))	V3
<((in Aluku)) <u>waata é kii me</u> > ((TRA: I'm thirsty/))	
C <((in Aluku)) <u>kon nay a// echee:chi// kon nay a GAW/ GAW</u> > ((TRA: come here///	
P <u>qui:ck//quick//</u> )	V11
C ((she comes back))	
O and that: (showing the switch) do you know what it is called/	V6

- with Laotian parents, actions of V1 and V4 type were prevailing (asks for an explanation, asks for a description, asks for an answer, asks for help / provides information, explanations, answers, describes, observes. See Table 5).

**Table 5: Excerpt from the transcripts of the exchanges within the Laotian dyad 2**

Parent (P) Child (C) Exchanges	Code
P You need to put that (showing the second lead) you understand /because it / it is there	V4
Yes	
C The current goes back and forth ti ti:t ti ti:t	
P <(( in Laotian)) ເອົາໃສ່ພື້ນ >((TRA: put it there/ ah\ we put it there:/ no/)) there you	V4
P go/ that's good	V2



- and finally, the directive style of Haitian parents is characterized by a high number of V2, V3 and V5 actions, as shown in Table 6.

**Table 6: Excerpt from the transcripts of the exchanges within the Haitian dyad 1**

Parent (P)	Child (C)	Exchanges involving an Observer (O)	Code
P	hm\ you see/	<((in Haitian Creole)) sak genyen ((TRA: what is happening) it wor::ks/	V6
	hm::=		V9
C	=<((laughing loudly)) I won// I won//>		
C	((COM: the child repeats the manipulation several times)) (2.6)		
O	why do you think it is working		
C	((COM: the child ignores the question))		
P	huh// say why// huh/ <((in Haitian Creole)) poukisa/ di/ ou pa vie di poukisa//> ((TRA: why/ say it/ you don't want to say why//))		V2

Previous studies have shown that suggestive and empowering accompaniment seems more favorable to children's discovery and understanding of the explored mechanisms (Ailincai & Weil-Barais, 2007).

We present here an extract from the transcripts of a Laotian dyad, including some suggestive actions (see Table 7):

**Table 7: Excerpt from the transcripts of the exchanges within the Laotian dyad 1**

Parent (P)	Child (C)	Exchanges involving an Observer (O)	Code
P	perhaps we already take the energy from there		V8
C	I cannot do it\		
P	we don't say that we cannot do it/ we try		V11
C	((the child tweaks it)) (01.42)		
P	Hm:: <((in Laotian) ມັນຊື່ເປັນຈັງໃດມັນຈັງຊື່ເດີມ > ((TRA: how are we going to make it work /what is going to happen/)) hop / there we go/		V6 V12
C	o::h. (seeing the lightbulb lighting up)		V7
P	<((in Laotian) ຕ້ອງມີ > ((TRA: there has to be::)) energy plu:s/ energy minus\		
C	it (electricity) is not comin:g\ (01.58)		
P	<((in Laotian) ບັນຫຍາງຄືບິບບິບມ້ກິນ > ((TRA: what is wrong/ it was ringing pi:p pi:p earlier))		V6
C	((the child tweaks it)) (01.06)		

The transcript shows an interaction based on a scientific procedure: starting from previous knowledge, it is possible to develop the hypothesis (the expected effects or the preliminary predictions) and procedures to validate this knowledge (or, on the contrary, to question it).

Schematization in the conceptualization process is important, as it allows us to see what the child has learned from the experience while facilitating the acquisition of concepts. Through the diagram which is complementary to the oral and written expressions, the child moves from a verbal model to a graphic drawing. Among the four groups participating in the study:

- all Laotian children correctly completed the diagram sheets for the two activities without the help of their parents (see Figure 6);
- three out of the four Haitian children completed the sheet with the help of their parents (although the latter were instructed not to intervene);
- for the Teko dyads, three children answered the oral questions correctly but needed parental help with the written exercise;
- all the Aluku children needed the help of the observer to complete the worksheets.

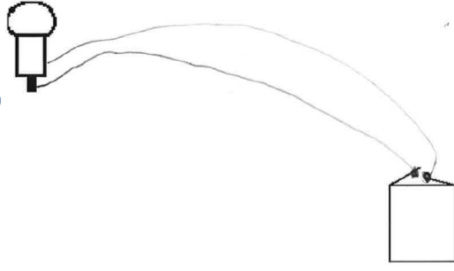
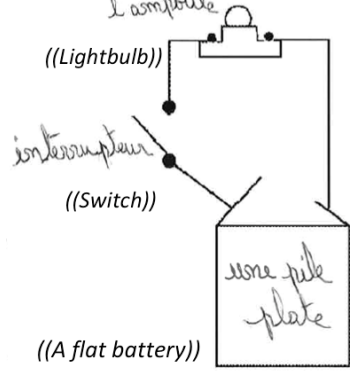
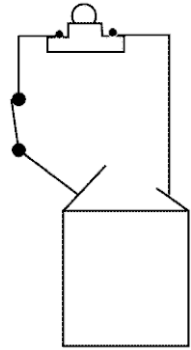
<p><b>Activity 1:</b> Link the lightbulb to the battery so that the lightbulb lights up</p>	<p><b>Activity 2:</b> Name each element of the electrical circuit and indicate when the circuit is “open” or “closed” and when the lightbulb lights up</p>	
	<p>Un circuit... ouvert... L'ampoule ne brille pas.                  ((With an <u>open circuit</u>, the lightbulb <u>does not light up</u>))</p>  <p>((Lightbulb))                  ((Switch))                  ((A flat battery))</p>	<p>Un circuit... fermé... L'ampoule brille.                  ((With a <u>closed circuit</u>, the lightbulb <u>lights up</u>))</p> 

**Figure 6: Diagram sheets made by a child of a Laotian dyad**

We are tempted to make a connection between the type of help given to the child (in particular the frequency of suggestive acts) and the success of the diagram drawing activity. The children who succeeded on their own were those who benefited from a high number of suggestive interactions with their parents. All Laotian children and three Teko children received suggestive support from their parents. However, the type of support differed between these two sociocultural groups. Laotian parents produced more verbal actions (V6), while Teko parents produced more non-verbal actions (N1 and N2). This type of behaviour is consistent with the everyday interactional style of the parents: learning activities among Teko dyads are characterized by silent demonstrations, observations and imitations, whilst Laotian dyads showed a high level of verbalization<sup>3</sup>.

During our observations, all dyads interacted by using different languages. Parents' interventions blended mother tongue and French according to the issues discussed with their children, developing learning situations “where the juxtaposition of two codes is perceived and interpreted by the participants as significative. It is a clear choice” (Alby, 2001, p. 76). Indeed, recent sociolinguistic studies have highlighted the regulatory function played by the choice of a language rather than another in a plurilingual context (Auer, 1996).

During our study, we observed that the participants in the survey often used their first language (different from French) mostly for three functional reasons:

- As a protective strategy, with the aim of not allowing the observers to understand some interactions considered as “private”;
- As an effect of the lack of confidence shown by some parents due to their limited skills in the French language;
- As a habit of interaction.

<sup>3</sup> For a wider discussion about the impact of verbal and nonverbal interactions on child development and social learning, see Bandura (1977) and Cho, Weil-Barais and Hoel (2008).

The first two excerpts (Tables 3 and 4) illustrate how the change of language has a regulatory function. For the other examples (Tables 5 and 6), the change reinforces the directive support. In Table 7 (French-Laotian), the change of language works as an indicator of contextualization: (Auer, 1995 ; Gumperz, 1982) “in the same way as intonation, body language or rhythm, contextualization is defined as an activity of the participants in the interaction that allows them to emphasize, maintain or change an aspect of the discursive context that, as a result, becomes in itself and for itself a means of interpreting the statement” (Alby & Migge, 2007, p. 57-58). The same conclusion appears in Box 6 (French-Creole Haitian) with the reformulation of “tell me why” in Haitian Creole, followed by an injunction: “or pa vle di poukisa”. Box 7 contains phenomena similar to those encountered in the previous examples. In the use of the two languages, what is significant is the alternation itself (and not the chosen language). It provides another means of reformulation (monolingual reformulation vs. bilingual reformulation) in order to give the child an understanding of the activity and to enable better communication.

## 5. Discussions

The purpose of this article was to present and compare the interactional patterns of sixteen dyads belonging to four linguistic and cultural minorities in French Guiana. Two of these groups are popularly perceived as “jungle people” (Teko Amerindians and Aluku Maroons), whilst the other two groups are considered immigrant minorities (the Laotian and Haitian diaspora). We observed the interactional patterns of these families in two distinct situations: spontaneous educational performances, as part of everyday routines, and structured educational performances in an experimental situation (during a scientific discovery activity, proposed by our research team).

Our first study was aimed at identifying the dominant interactional style and the interactional pattern within the same sociocultural group.

The results highlighted some relevant specificities: Teko dyads presented a preponderance of empowering and disjointed interactions; Aluku dyads were more empowering and directive; Laotian dyads showed a pattern composed of suggestive and directive interactions while the Haitian dyads’ pattern was more influenced by directive and disjointed interactions. Following other scholars, we considered that specificities between dyads belonging to the same sociocultural group could be explained by the influences of interacting systems (Bronfenbrenner, 1979) which are specific to each dyad: the influence of the immediate environment (the experience of family members, the socio-economic situation of the family, the aspirations of the family, etc.) or the influence of more distant systems (the “traditional culture”, the creolized culture and the globalized culture) (Hidair & Ailincal, 2014; Ali, 2016). Nevertheless, the presence of a dominant interaction style for each community could be explained by the fact that these sociocultural groups maintain a strong cultural identity associated with geographical isolation. In addition, we observed that all of families from our sample kept on using their first language in domestic interactions and adopting a “public” discourse promoting the preservation of the culture of origin.

Our second study was aimed at describing interactional styles in an experimental situation and the data we collected revealed a significative variation in the interaction style of each dyad compared to their everyday style associated with a general predominance of the directive style for the four sociocultural groups.

This overrepresentation of directive interactions in our sample may be associated with the parents' desire to see their children succeed in a task perceived as something similar to school homework<sup>4</sup>; it could also be explained by the experimental nature of the activity (observed by a researcher external to the family), which could have encouraged parents to adopt a directive approach to reach the goal; moreover, the novel nature of the experimental activity seemed to arouse parents' desire to discover "how it works", stimulating parents' over-manipulation and limiting children interventions (confirming the general tendency we already observed in our previous research in France's urban scientific museums.). The dominance of directive parental behaviour in experimental situations was also reported by the results of our previous works exploring the interaction style of Parisian parents when accompanying their children on a visit to a scientific and technical museum (Ailincal 2005; Ailincal & Weil-Barais, 2007).

The presence of wide patterns of interactional variability within the same dyad and within the same sociocultural group is coherent with the results presented by other researchers and by our previous works on educational practices of other autochthonous communities in French Guiana and French Polynesia (LeVine & New, 2008; Ali, 2016). We suggest that, despite the geographical isolation of these populations, the interactive dynamics linking the different levels and niches of the socioeconomic system (i.e. the context: school, administrative bodies, other sociocultural groups, languages, etc.) influence parents' educational strategies, producing an evolving educational ideology based on a community identity (and the perception of belonging to a "group" with a specific cultural tradition. Hidair & Ailincal, 2014; Ali & Ailincal, 2016a. See also Mugny & Carugati, 1985; Pourtois & Desmet 2004; Vandenplas-Holper, 1987).

In our opinion, this kind of "top-down" ethnic transfiguration has been able to transform the local educative paradigms, both in terms of identity and family educational practices, with the aim of facilitating children's school success but to the detriment of adaptation to the natural ecosystem where they live. However, as parents' educational theories (and their prejudices, stereotypes and beliefs about their children's development) are the most of the time implicit, it is difficult for teachers to understand and possibly take into account the cultural specificities of their students. Actually, our results stimulate a new research question: how does the difference between family and school educational practices influence students' school behavior?

The results of this study (in particular the interactive styles of the parents, the cultural particularisms versus the behavioral similarities in an educational activity of a scientific nature, the practice of the codic alternation in the parent-child exchanges) could contribute to the understanding of the differences of the educational adaptability of the minority groups we studied.

### **5.1. Research limits and biases**

One of the limitations of this study is related to the small size of our sample, due to the fact that the methodology we used required several ethnographic missions to isolated sites where it was often difficult to obtain the agreement of the local communities. Nevertheless, in the future, the corpus could be increased using the same research protocol among other socio-cultural groups.

---

<sup>4</sup> Actually, in other works we analyzed the impact of compulsory schooling in transforming the educative logics, ideologies and strategies among autochthonous communities in French Guiana and Polynesia (Ali, 2016; Ali & Ailincal, 2016b and 2017).

In addition, the results we obtained need to be interpreted to avoid any cultural determinism (linking in an univocal way every culture with a “typical” way of parenting). In fact, the global interactive patterns of the groups we studied only represent the most recurrent behavior in the dyads of a given group; however, the results reported in this article highlight the individual footprint of each interactive pattern, according to the interactive ecosystem dynamics in which the dyad evolves.

An eventual research bias could be found in our choice to compare a natural situation (Study 1) and an experimental situation (Study 2). In Study 2, the imposed activity and the presence of the camera could modify the behavior of the interactants. However, the use of family observers seems to have mitigated this constraint. The observation of the interactive style in learning activities could also have been done in a natural setting, observing the parental accompaniment to the homework requested by the school and not during an activity imposed by the researcher. However, this last choice would have generated other variables (such as the discipline involved in the task or the duration of the activity) and would have required a prolonged presence of the observers within the families.

## **5.2. Originality of work**

The originality of this work consists, on the one hand, of the subject of the study (to our knowledge it is the first research that tries to make a comparative account of the parental educational practices of these socio-cultural groups) and, on the other hand, of the analysis of the data, comparing intradyadic and interdyadic interactions in two contrasting types of activity.

## **6. Conclusion**

The research presented in this article was born from questioning the educational system of French Guiana which has a high rate of out-of-school students and very low primary school assessment scores. Taking into account the specificities of the Guianese context, marked by multiculturalism and plurilingualism, our hypothesis suggested that the gap between family and school interactions would have an impact on the pupil's early years of schooling. Our exploratory research was aimed at analyzing the interactive family styles according to two variables: the socio-cultural context of belonging of the dyads participating in the study (four distinct contexts concerning the culture and mother tongue) and the context of the interactive situation observed (daily activities vs learning activities).

The main results were:

- The studied groups are distinguished from each other by interactivity macro-patterns. Thus, the hypothesis that parental interactive styles are related to the socio-economic ecosystem, and the social history of families and communities has been confirmed. The dyads participating in our study showed a predominance of the following interactive styles:

- Teko, an empowering and disjointed style;
- Aluku, an empowering and directive style;
- Laotians of French Guiana, a suggestive style;
- Haitians of French Guiana, a directive and disjointed style.

- In the context of daily activities, interactive style differences were observed within the same sociocultural group (interdiadic variability). For example, in the group of Laotian dyads, one pair is rather suggestive, while another rather empowering. These differences can be explained by the interactive ecosystem dynamics in which the family evolves. However, the interdiadic variations within the same socio-cultural group do not erase the dominant interactional style, which is present among all the dyads.

- In the context of learning-oriented, school-based activities, all the dyads showed a directive style. The assumption of interactive style variability by type of activity was confirmed (intradynamic variability). For example, the empowering daily style of a teko dyad becomes directive in a school-based activity. These results could be explained either by the gap between daily activities and activities of school nature (not linked with the local culture) or by parent educational ideologies.

- Our research has highlighted the existence of two major interactive styles in parent-child interactions, depending on the interactional context, which we name:

- The daily interactive style; and
- The epistemic interactive style.

Epistemic family interactions could be a favorable ground for encounters between the two main educational environments where children evolve: the family, impregnated by the local culture, and the school, vector of the national culture. Those kind of domestic interactions could be integrated to facilitate exchanges between families and school, discussions on working arrangements and family and school practices around the same activities, with the aim to develop a different approach to homework, and involving parents in a tripartite collaboration with teachers and pupils.

Ultimately, the results related to the day-to-day educational practices of the socio-cultural groups studied could become part of the training of prospective and confirmed teachers working in isolated areas of French Guiana, in order to provide better knowledge of local customs in this plurilingual and multicultural context and to facilitate the school-family partnership.

In conclusion, we would like to add that, in the current situation, whilst the French intercultural model is being challenged by nationalist and ethnocentric educational ideologies, we sincerely hope that our study may contribute to opening up new research paths and developing similar ethnographic surveys in other little known multicultural contexts of France. Paraphrasing Hermann Melville, we may suggest that, when talking about school and education issues, “ignorance is the parent of fear” (Melville, 1851: 35).

## **Bibliography**

- Adams, R.S. (1972). Observational Studies of Teacher Role. *Revue Internationale de Pédagogie*, 18(4), 440-459.
- Ailincăi, R. (2005). *Un dispositif d'éducation parentale. Sensibilisation des parents à leur rôle d'accompagnateur de leur enfant dans le cadre d'un musée à caractère scientifique et technique*. Thèse de doctorat en sciences de l'éducation publiée 2011, Université Paris 5.
- Ailincăi, R., & Weil-Barrais, A. (2007). Un dispositif de sensibilisation parentale dans un musée scientifique. *La revue internationale de l'éducation familiale*, 2, 87-108.

- Ailincal, R., & Weil-Barais, A. (2013). Parenting Education: Which Intervention Model to Use? *Procedia-Social and Behavioral Sciences*, 106, 2008-2021.
- Ailincal, R., Jund, S., & Ali, M. (2012). Comparaison des écosystèmes éducatifs chez deux groupes d'Amérindiens: les Wayãpi et les Wayana. *La Revue française d'éducation comparée, Raisons, Comparaison, Education*, 8, 55-90.
- Alby, S. (2001). *Contacts de langues en Guyane française, une description du parler bilingue kali'na-français*. Thèse de doctorat en sciences du langage, Université Lyon II - Lumière.
- Alby, S., & Launey, M. (2007). Former des enseignants dans un contexte plurilingue et pluriculturel. In I. Léglise & B. Migge (Eds.), *Pratiques et représentations linguistiques en Guyane* (pp. 317-348). Paris : IRD Editions.
- Alby, S., & Migge, B. (2007). Alternances codiques en Guyane française. Les cas du kali'na et du nenge. In I. Léglise et B. Migge (Eds.), *Pratiques et représentations linguistiques en Guyane* (pp. 49-72). Paris : IRD Editions.
- Ali, M. (2016). *De l'apprentissage en famille à la scolarisation républicaine : deux cas d'étude en Guyane et Polynésie française*. Thèse de doctorat en ethnologie, anthropologie biologique et préhistoire, Université de la Polynésie française.
- Ali, M., & Ailincal, R. (2013). Learning and Growing in Indigenous Amazon: The Education System of French Guiana Wayana-Apalai Communities. *Procedia-Social and Behavioral Sciences*, 106, 1742-1752.
- Ali, M., & Ailincal, R. (2016a) Parenthood and the Wayana People. *Sociology Mind*, 6, 149-161.
- Ali, M., & Ailincal, R. (2016b, octobre). *L'École dans les Outre-mer et l'illusion de l'ascenseur social : réflexions sur la scolarisation obligatoire des peuples autochtones de la Guyane et de la Polynésie*. Communication au 13<sup>ème</sup> colloque international de l'AFDECE : Réformer l'École ? L'apport de l'éducation compare. Paris.
- Ali, M., & Ailincal, R. (2017). La ideología educativa de los Wayana-Apalai de la Guyana francesa: una identidad cultural autóctona en vía de transfiguración. *Revista Kavilando*, 9(1), 145-169.
- Archimbaud A. et Chapdelaine M.-A. (2015). *Suicides des jeunes Amérindiens en Guyane française : 37 propositions pour enrayer ces drames et créer les conditions d'un mieux-être*. Rapport à Monsieur le Premier Ministre. Paris : Ministère des Outre-mer.
- Auer, P. (1995). The pragmatics of code-switching, a sequential approach. In Milroy et Muysken (Eds.), *One speaker, two languages, cross-disciplinary perspectives on code-switching* (pp.115-135). Cambridge: Cambridge University Press.
- Auer, P. (1996). *Bilingual conversation, 10 ans après*. *AILE*, 7, 9-34.
- Baccaini, B., de Lapasse, B., Lebeaupin, F., & Monso, O. (2014). Le retard scolaire à l'entrée en 6e: plus fréquent dans les territoires les plus défavorisés. *Insee Première*, 1512, 1-4.
- Baldwin, A. L. (1948). Socialization and the parent-child relationship. *Child Development*, 19(3), 127-136.
- Bandura, A. (1977). Self-efficacy: toward a unifying theory of behavioral change. *Psychological Review*, 84(2), 191-215.
- Barocas, R., Seifer, R., Sameroff, A.J., Andrews, T.A., Croft, R.T., & Ostrow, E. (1991). Social and interpersonal determinants of developmental risk. *Developmental Psychology*, 27(3), 479-488.
- Bayart, P., Dorelon P., & Hurpeau B. (2013). *Enquête Information et Vie Quotidienne. Lire, écrire, compter : des savoirs fragiles en Guyane. Premiers résultats*. Cayenne : INSEE.
- Baumrind, D. (1971). Current patterns of parental authority. *Developmental Psychology*, 4(1, Pt.2), 1-103.

- Baumrind, D. (1978). Parental disciplinary patterns and social competence in children. *Youth & Society*, 9(3), 239-276.
- Baumrind, D. (1989). Rearing competent children. In W. Damon (Ed.), *Child development today and tomorrow* (pp. 349-378). San Francisco: Jossey-Bass.
- Becker, W. C. (1964). Consequences of different kinds of parental discipline. In M. L. Hoffman & L. W. Hoffman (Eds.), *Review of child development research* (pp. 168-208). New York: Russell Sage Foundation.
- Block, J.H. (1985). *The Child-rearing Practices Report (CRPR): A set of Q items for the description of parental socialization attitudes and values*. Berkeley [CA]: Institute of Human Development.
- Bloom, B.S. (1964). *Stability and Change in human characteristics*. New York: John Wiley and sons.
- Bronfenbrenner, U. (1979). *The ecology of human development: experiments by nature and design*. Cambridge: Harvard University Press.
- Chao, R.K. (1994). Beyond parental control and authoritarian parenting style : Understanding Chinese parenting through the cultural notion of training. *Child Development*, 65(4), 1111-1119.
- Cho, H.Y., Weil-Barais, A., & Hoel, J. (2008). D'où vient la supériorité des enfants coréens en mathématiques ? *Carrefours de l'Éducation*, 28, 121-137.
- Dearing E., Simpkins S., Holly Kreider H. et alii (2006). Family Involvement in School and Low-Income Children's Literacy: Longitudinal Associations Between and Within Families. *Journal of Educational Psychology*, 98(4), 653-664.
- Deković, M., Janssens, J. M., & Gerris, J. R. (1991). Factor structure and construct validity of the Block Child Rearing Practices Report (CRPR). *Psychological Assessment: A Journal of Consulting and Clinical Psychology*, 3(2), 182.
- De Landsheere, G., & Bayer, E. (1969). *Comment les maîtres enseignent. Analyse des interactions verbales en classe*. Bruxelles : Ministère de l'Éducation Nationale et de la Culture, Administration des études.
- Deslandes R. (1996). *Collaboration entre l'école et les familles : Influence du style parental et de la participation parentale sur la réussite scolaire au secondaire*. Thèse de doctorat de Psychopédagogie. Laval [Québec] : Université Laval.
- Deslandes, R., & Cloutier, R. (2005). Pratiques parentales et réussite scolaire en fonction de la structure familiale et du genre des adolescents. *Revue française de pédagogie*, 151, 61-74.
- Dornbusch, S., Ritter, P., Leiderman, P., Roberts, D. & Fraleigh, M. (1987). The relation of parenting style to adolescent school performance. *Child Development*, 58, 1244-1257.
- Duru-Bellat M., & Van Zanten A. (2006). *Sociologie de l'école*. Paris : Armand Colin.
- Epstein, J. L., Connors, L. J., & Salinas, K. C. (1993). *High school and family partnerships: Surveys and summaries*. [Instrument de mesure]. Center on Families, Communities, Schools and Children's Learning.
- Feinberg E. M., Jones E. D., Kan L. M. et alii (2010). Effects of Family Foundations on Parents and Children: 3.5 Years After Baseline. *Journal of Family Psychology*, 24 (5), 532-542.
- Fontaine, A.-M. (1990). Pratiques éducatives familiales et motivation pour la réussite d'adolescents en fonction du contexte social. In S. Dansereau, B. Terrisse & J.-M. Bouchard (Éds.), *Éducation familiale et intervention précoce* (pp. 209-224). Montréal : Agence d'Arc.
- François, A., & Weil-Barais, A. (2003). Élaboration des connaissances relatives à un dispositif technique dans un contexte d'interactions parent-enfant. *Bulletin de Psychologie*, 56(4), 509-519.



- Gragnic, B., & Horatius-Clovis, H. (2014). *L'état de l'école en Guyane*. Cayenne : Académie de la Guyane, IRIG Défis, INSEE.
- Groux, D. (1997). L'éducation comparée: approches actuelles et perspectives de développement. *Revue française de pédagogie*, 121, 111-139.
- Gumperz, J.J. (1982). *Discourse strategies*. Cambridge: Cambridge University Press.
- Harwood, R. L., Miller, J. G., & Irizarry, N. L. (1995). *Culture and attachment: Perceptions of the child in context*. Guilford Press.
- Hidair, I., & Ailincal, R. (2014). Migration and Identities of "Indigenous" Sociocultural Groups in French Guiana: A Case Study of Students Along the Oyapock and Maroni Rivers. *Procedia-Social and Behavioral Sciences*, 174(12), 878-885.
- Hurault, J.-M. (1965). *La vie matérielle des Noirs Réfugiés Boni et des Indiens Wayana du Haut-Maroni, Guyane Française : agriculture, économie et habitat*. Paris : ORSTOM.
- ICAR (2013). Convention de transcriptions ICOR, UMR 5191, CNRS Lyon 2, ENS de Lyon : [http://icar.cnrs.fr/projets/corinte/documents/2013\\_Conv\\_ICOR\\_250313.pdf](http://icar.cnrs.fr/projets/corinte/documents/2013_Conv_ICOR_250313.pdf)
- Kellerhals, J., & Montandon, C. (1991). *Les stratégies éducatives des familles: milieu social, dynamique familiale et éducation des préadolescents*. Neuchâtel Paris: Delachaux et Niestlé.
- Khanna S. M., & Kendall C. P. (2009). Exploring the Role of Parent Training in the Treatment of Childhood Anxiety. *Journal of Consulting and Clinical Psychology*, 77(5), 981-986.
- Kochanska, G., Kuczynski, L., & Radle-Yarrow, M. (1989). Correspondance between mothers' self-reported and observed child-rearing practices. *Child Development*, 60, 56-63.
- Laëthier, M. (2007). Pratiques langagières des Haïtiens dans l'île de Cayenne. In I. Léglise et B. Migge (Eds.), *Pratiques et représentations linguistiques en Guyane* (pp. 193-208). Paris : IRD Editions.
- Lahaye, W., Pourtois, J.-P., & Desmet, H. (2007). *Transmettre. D'une génération à l'autre*. Paris : PUF.
- Lautrey, J. (1984). *Classe sociale, milieu familial, intelligence*. Paris: Presses Universitaires de France.
- LeVine, R.A., & New, R.S. (2008) (Eds.). *Anthropology and Child Development. A Cross-Cultural Reader*. Oxford: Blackwell Publishing.
- Lévi-Strauss, C. (1962). *La pensée sauvage*. Paris: Plon.
- Lin, C.-Y., & Fu V.R. (1990). A comparison of child-rearing practices among Chinese, immigrant Chinese, and Caucasian-American parents, *Child Development*, 61(2). 429-433.
- Maccoby, E. E., & Martin, J. A. (1983). Socialization in the context of the family: Parent-child interaction. In P. Mussen & M. E. Hetherington (Eds.). *Handbook of child psychology: formerly Carmichael's Manual of child psychology* (pp. 1-102). Wiley. Paul H. Mussen, editor.
- Martin, A., Ryan, R. M., & Brooks-Gunn, J. (2007). The joint influence of mother and father parenting on child cognitive outcomes at age 5. *Early Childhood Research Quarterly*, 22, 423-439.
- Melville, H. (1851 [1994]). *Moby Dick*. London: Penguin.
- Meuret, D., & Morlaix, S. (2006). L'influence de l'origine sociale sur les performances scolaires : par où passe-t-elle ? *Revue française de sociologie*, 47 (1), 49-79.
- Mugny, M., & Carugati, F. (1985). *L'intelligence au pluriel*, Lausanne: Delval
- Murat, F. (2009). Le retard scolaire en fonction du milieu parental: L'influence des compétences des parents. *Economie et statistique*, 424-425, 103-124.

- OCDE - Organisation de Coopération et de Développement Economique. (2014). *Résultats du PISA 2012 : Savoirs et savoir-faire des élèves : Performance des élèves en mathématiques, en compréhension de l'écrit et en sciences* (Vol I). Paris : PISA - OCDE.
- OCDE - Organisation de Coopération et de Développement Economique. (2015). *Résultats du PISA 2012. Note par pays : France*. Paris : PISA - OCDE.
- Potvin, J.-Y., Kervahut, T., Garcia, B.-L., & Rousseau, J.-M. (1996). The vehicle routing problem with time windows – Part I: Tabu search. *INFORMS Journal on Computing*, 8, 158-164.
- Pourtois, J.-P. (1979). *Comment les mères enseignent à leur enfant*. Paris : PUF.
- Pourtois, J.-P., & Desmet, H. (2004). *L'éducation implicite*. Paris : PUF.
- Rickel, A. U., & Biasatti, L. L. (1982). Modification of the block child rearing practices report. *Journal of Clinical Psychology*, 38(1), 129-134.
- Spoth, R., Randall, G. K., & Shin, C. (2008). School success through partnership-based family competency training: Experimental study of long-term outcomes. *School Psychology Quarterly*, 23(1), 70-89.
- Steinberg L., Lamborn S. D., Dornbusch S. M. & alii (1992). Impact of parenting practices on adolescent achievement: Authoritative parenting, school involvement, and encouragement to succeed. *Child Development*, 63, 1266-1281.
- Tavernier, J.-L. (2012) (Eds.). *Immigrés et descendants d'immigrés en France*. Paris : INSEE
- Terrisse, B., & Larose, F. (2000). *L'échelle des compétences éducatives parentales (ECEP): manuel*. [Questionnaire et manuel]. Éditions du Ponant.
- Vandenplas-Holper, C. (1987). Les théories implicites du développement et de l'éducation. *European Journal of Psychology of Education*, 2(1), 17-39.
- Vygotsky, L.S. (1934 [1978]). *Mind and society: The development of higher mental processes*. Cambridge, MA: Harvard University Press.
- Weil-Barais, A., Bernard, F. X., Cho, H.Y., & Lacroix, F. (2008). Développement des compétences cognitives des enfants dans des contextes d'interaction éducative. *TRANEL*, 49, 169-186.